

Quantum™

INSTALLATION INSTRUCTIONS

English (EN)

Date: 12-2015

Document number: 87209-1

© 2015 Raymarine UK Limited



Raymarine®
BY  **FLIR**

Trademark and patents notice

Raymarine, Tacktick, Clear Pulse, Truzoom, HSB, SeaTalk, SeaTalk^{hs}, SeaTalk^{ng}, Micronet, Raytech, Gear Up, Marine Shield, Seahawk, Autohelm, Automagic, and Visionality are registered or claimed trademarks of Raymarine Belgium.

FLIR, DownVision, SideVision, Dragonfly, Quantum, Instalert, Infrared Everywhere, and The World's Sixth Sense are registered or claimed trademarks of FLIR Systems, Inc.

All other trademarks, trade names, or company names referenced herein are used for identification only and are the property of their respective owners.

This product is protected by patents, design patents, patents pending, or design patents pending.

Fair Use Statement

You may print no more than three copies of this manual for your own use. You may not make any further copies or distribute or use the manual in any other way including without limitation exploiting the manual commercially or giving or selling copies to third parties.

Software updates

Important: Check the Raymarine website for the latest software releases for your product.

www.raymarine.com/software

Product handbooks

The latest versions of all English and translated handbooks are available to download in PDF format from the website www.raymarine.com. Please check the website to ensure you have the latest handbooks.

Copyright ©2015 Raymarine UK Ltd. All rights reserved.

Contents

Chapter 1 Important information.....	7	Chapter 8 Technical support	39
Certified Installation	7	8.1 Raymarine product support and servicing	40
Transmitted power density levels	7	8.2 Operation instructions.....	41
IEEE statement	7	8.3 Viewing product information	41
ICNIRP Guidelines.....	7	Chapter 9 Technical specification.....	43
Water ingress	7	9.1 Technical specification.....	44
Disclaimer	8	Chapter 10 Spares and accessories	45
EMC installation guidelines	8	10.1 Quantum™ Radar accessories.....	46
Compass safe distance.....	8	10.2 Network hardware	46
Declaration of conformity.....	8	10.3 Network cable connector types.....	47
Connections to other equipment	8	10.4 RayNet to RayNet cables and connectors	48
Product disposal.....	8	10.5 RayNet to RJ45 adapter cables.....	49
Warranty registration.....	8		
IMO and SOLAS.....	8		
Radar licensing.....	9		
FCC Notice - Radar	9		
Technical accuracy	9		
Operation instructions	9		
Retain your Wi-Fi passcode.....	9		
Chapter 2 Document and product information.....	11		
2.1 Document information	12		
2.2 Parts supplied.....	13		
2.3 Quantum™ Radome product overview	13		
Chapter 3 Planning the installation	15		
3.1 Installation checklist	16		
3.2 Required additional components	16		
3.3 Multifunction display compatibility.....	17		
3.4 Multifunction display software requirements	17		
3.5 Tools required	18		
3.6 Typical systems	18		
3.7 Location requirements	19		
3.8 Product dimensions.....	20		
Chapter 4 Cables and connections.....	21		
4.1 General cabling guidance	22		
4.2 Connections overview	23		
4.3 Power connection	25		
4.4 Network connection.....	27		
Chapter 5 Mounting.....	29		
5.1 Mounting the scanner.....	30		
5.2 Radar scanner protection — sailing vessels.....	31		
Chapter 6 System checks and troubleshooting	33		
6.1 Post installation procedures	34		
6.2 Troubleshooting	35		
Chapter 7 Maintenance	37		
7.1 Maintenance.....	38		
7.2 Unit cleaning instructions.....	38		

Chapter 1: Important information

Certified Installation

Raymarine recommends certified installation by a Raymarine approved installer. A certified installation qualifies for enhanced product warranty benefits. Contact your Raymarine dealer for further details, and refer to the separate warranty document packed with your product.



Warning: Product installation and operation

- This product must be installed and operated in accordance with the instructions provided. Failure to do so could result in personal injury, damage to your vessel and/or poor product performance.
- Raymarine recommends certified installation by a Raymarine approved installer. A certified installation qualifies for enhanced product warranty benefits. Contact your Raymarine dealer for further details, and refer to the separate warranty document packed with your product.



Warning: Potential ignition source

This product is NOT approved for use in hazardous/flammable atmospheres. Do NOT install in a hazardous/flammable atmosphere (such as in an engine room or near fuel tanks).



Warning: Positive ground systems

Do not connect this unit to a system which has positive grounding.



Warning: Power supply voltage

Connecting this product to a voltage supply greater than the specified maximum rating may cause permanent damage to the unit. Refer to the *Technical specification* section for voltage rating.



Warning: Switch off power supply

Ensure the vessel's power supply is switched OFF before starting to install this product. Do NOT connect or disconnect equipment with the power switched on, unless instructed in this document.

Caution: Power supply protection

When installing this product ensure the power source is adequately protected by means of a suitably-rated fuse or automatic circuit breaker.



Warning: High voltages

This product may contain high voltages. Do NOT remove any covers or otherwise attempt to access internal components, unless specifically instructed in the documentation provided.



Warning: Radio frequency radiation hazard

The radar scanner transmits electromagnetic energy at microwave frequencies which can be harmful, particularly to the eyes. Do NOT look at the scanner from close range. Ensure personnel are clear of the scanner when it is powered on.

For safety reasons, the radar must be installed above head height, out of range of personnel.

Caution: Service and maintenance

This product contains no user serviceable components. Please refer all maintenance and repair to authorized Raymarine dealers. Unauthorized repair may affect your warranty.

Transmitted power density levels

- A power density level of 10 W/m² does not occur at any point.
- A power density level of 100 W/m² does not occur at any point.

IEEE statement

IEEE C95.1 – 2005 – Standard for Safety Levels with respect to Human Exposure to Radio Frequency Electromagnetic Fields, 3 kHz to 300 GHz.

ICNIRP Guidelines

When properly installed and operated, the use of this Radar conforms to: ICNIRP Guidelines 1998 - International Commission on Non-Ionising Radiation Protection: Guidelines for limiting exposure to time-varying electric, magnetic and electro-magnetic fields (up to 300 GHz) 1998.

Water ingress

Water ingress disclaimer

Although the waterproof rating capacity of this product meets the stated IPX standard (refer to the product's *Technical Specification*), water intrusion and subsequent equipment failure may occur if the product is subjected to commercial high-pressure washing. Raymarine will not warrant products subjected to high-pressure washing.

Disclaimer

Raymarine does not warrant that this product is error-free or that it is compatible with products manufactured by any person or entity other than Raymarine.

Raymarine is not responsible for damages or injuries caused by your use or inability to use the product, by the interaction of the product with products manufactured by others, or by errors in information utilized by the product supplied by third parties.

EMC installation guidelines

Raymarine equipment and accessories conform to the appropriate Electromagnetic Compatibility (EMC) regulations, to minimize electromagnetic interference between equipment and minimize the effect such interference could have on the performance of your system

Correct installation is required to ensure that EMC performance is not compromised.

Note: In areas of extreme EMC interference, some slight interference may be noticed on the product. Where this occurs the product and the source of the interference should be separated by a greater distance.

For **optimum** EMC performance we recommend that wherever possible:

- Raymarine equipment and cables connected to it are:
 - At least 1 m (3 ft) from any equipment transmitting or cables carrying radio signals e.g. VHF radios, cables and antennas. In the case of SSB radios, the distance should be increased to 7 ft (2 m).
 - More than 2 m (7 ft) from the path of a radar beam. A radar beam can normally be assumed to spread 20 degrees above and below the radiating element.
- The product is supplied from a separate battery from that used for engine start. This is important to prevent erratic behavior and data loss which can occur if the engine start does not have a separate battery.
- Raymarine specified cables are used.
- Cables are not cut or extended, unless doing so is detailed in the installation manual.

Note: Where constraints on the installation prevent any of the above recommendations, always ensure the maximum possible separation between different items of electrical equipment, to provide the best conditions for EMC performance throughout the installation

Compass safe distance

To prevent potential interference with the vessel's magnetic compasses, ensure an adequate distance is maintained from the product.

When choosing a suitable location for the product you should aim to maintain the maximum possible distance from any compasses. Typically this distance should be at least 1 m (3 ft) in all directions. However for some smaller vessels it may not be possible to locate the product this far away from a compass. In this situation, when choosing the installation location for your product, ensure that the compass is not affected by the product when it is in a powered state.

Declaration of conformity

Raymarine UK Ltd. declares that this product is compliant with the essential requirements of R&TTE directive 1999/5/EC.

The original Declaration of Conformity certificate may be viewed on the relevant product page at www.raymarine.com.

Connections to other equipment

Requirement for ferrites on non-Raymarine cables

If your Raymarine equipment is to be connected to other equipment using a cable not supplied by Raymarine, a suppression ferrite **MUST** always be attached to the cable near the Raymarine unit.

Product disposal

Dispose of this product in accordance with the WEEE Directive.



The Waste Electrical and Electronic Equipment (WEEE) Directive requires the recycling of waste electrical and electronic equipment.

Warranty registration

To register your Raymarine product ownership, please visit www.raymarine.com and register online.

It is important that you register your product to receive full warranty benefits. Your unit package includes a bar code label indicating the serial number of the unit. You will need this serial number when registering your product online. You should retain the label for future reference.

IMO and SOLAS

The equipment described within this document is intended for use on leisure marine boats and workboats NOT covered by International Maritime Organization (IMO) and Safety of Life at Sea (SOLAS) Carriage Regulations.

Radar licensing

Installation and operation of this radar may be subject to individual licensing of the equipment, operator or vessel. You are strongly advised to check with the requirements of the licensing authority of your national administration. In case of any difficulties, contact your local Raymarine dealer.

FCC Notice - Radar

Changes or modifications to this equipment not expressly approved in writing by Raymarine Incorporated could violate compliance with FCC rules and void the operator's authority to operate the equipment.

Technical accuracy

To the best of our knowledge, the information in this document was correct at the time it was produced. However, Raymarine cannot accept liability for any inaccuracies or omissions it may contain. In addition, our policy of continuous product improvement may change specifications without notice. As a result, Raymarine cannot accept liability for any differences between the product and this document. Please check the Raymarine website (www.raymarine.com) to ensure you have the most up-to-date version(s) of the documentation for your product.

Operation instructions

For detailed operation instructions for your product, refer to the documentation that accompanies your display.

Retain your Wi-Fi passcode

To connect to the Radar using Wi-Fi (wireless), you will need to know the unit's **SSID**, and **Passcode** (password).

Both the SSID and Passcode are provided on the Radar scanner packaging, on the serial number label on the underside of the unit, on a label attached to the power cable and on spare serial number labels supplied in the box. You may wish to make a separate note of this information (kept in a secure location). You should also keep the Radar scanner packaging in a safe place for future reference.

Chapter 2: Document and product information

Chapter contents

- [2.1 Document information on page 12](#)
- [2.2 Parts supplied on page 13](#)
- [2.3 Quantum™ Radome product overview on page 13](#)

2.1 Document information

This document contains important information related to the installation of your Raymarine product.

The document includes information to help you:

- plan your installation and ensure you have all the necessary equipment;
- install and connect your product as part of a wider system of connected marine electronics;
- troubleshoot problems and obtain technical support if required.

This and other Raymarine product documents are available to download in PDF format from www.raymarine.com.

Applicable products

This document is applicable to the following products:

	Part number	Name	Description
	E70210	Quantum™ Radome	Quantum™ Radar scanner with 10 m power cable

Document illustrations

Your product may differ slightly from that shown in the illustrations in this document, depending on product variant and date of manufacture.

All images are provided for illustration purposes only.

Document conventions

The following conventions are used throughout this document when referring to:

Type	Example	Convention
Procedures for performing specific tasks using the product's user interface.	Select Set-Up .	The term "Select" is used to refer to the action of: <ul style="list-style-type: none"> • Touchscreen control — using your finger to select a menu option or item on the screen. • Physical buttons — Highlighting an item using the navigational buttons and confirming the selection by pressing the OK button.
Procedures for navigating menu hierarchies.	1. The internal sonar module is turned off from the	Menu hierarchies are used in this document to provide a quick

Type	Example	Convention
	Fishfinder application menu: Menu > Set-up > Sounder Set-up > Internal Sounder . 2. The internal GPS can be switched off from the Set-up menu: Menu > Set-up > GPS Set-up > Internal GPS .	summary on how to access a particular function or menu option.

Product documentation

The following documentation is applicable to your product:

Description	Part number
Quantum™ Radome Installation instructions Installation of a Quantum™ Radar scanner and connection to a wider system of marine electronics.	87209 / 88055
Quantum™ Radome Mounting template Mounting diagram for surface mounting a Quantum™ Radar scanner.	87257
Lighthouse MFD Operation Instructions Details the operation of the Radar application for a Series, c Series, e Series, eS Series, and gS Series multifunction displays.	81360

Operation instructions

For detailed operation instructions for your product, refer to the documentation that accompanies your display.

LightHouse MFD Operation instructions

For operation instructions for your MFD, including 'Getting Started' and 'System Checks' information please use the **User Manual icon on the Homescreen**.

	the LightHouse Operation Instructions (81360) can also be downloaded from the Raymarine website: www.raymarine.com/manuals
--	---

2.2 Parts supplied

The following items are supplied with your product.

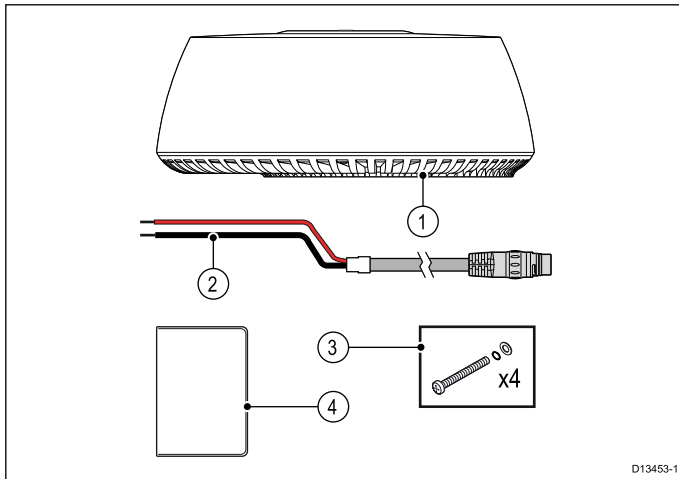

Item	Description	Quantity
1	Quantum™ Radome	1
2	10 m (32.8 ft) Power cable	1
3	M8 mounting bolts with spring washers and flat washers	4
4	Documentation pack (including mounting template)	1

2.3 Quantum™ Radome product overview

The Quantum™ Radome is a compact, solid-state Radar scanner, utilizing CHIRP pulse compression for improved range resolution, and Wi-Fi connectivity for easier installation. In conjunction with a compatible multifunction display, the Quantum™ scanner provides a map-like representation of the area around your vessel, enabling you to identify other vessels, buoys, and land features such as coastlines and hills.

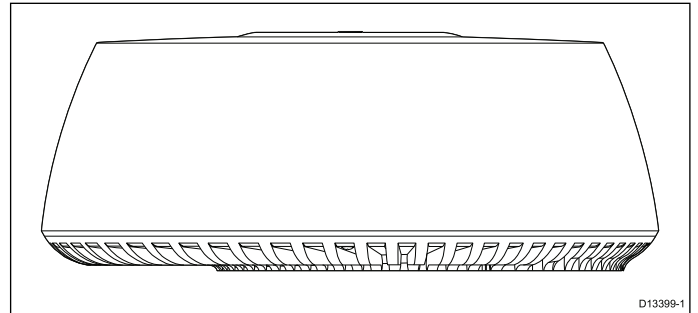

The Quantum™ Radome has the following features:

- Solid-state technology (no magnetron) for improved efficiency, and rapid start-up.
- Range performance up to 24 nm (dependent on installation location).
- CHIRP pulse compression for improved target range resolution, and reduced background noise.
- Data connection via Wi-Fi, or Raynet cable.
- Radar image display and control via Raymarine multifunction display.
- 24 RPM scanner rotation.
- Low power consumption.
- 12 V or 24 V operation.
- Waterproof to IPX 6.

Multiple Quantum™ Radar scanners

Only 1 (one) Quantum™ Radar scanner can be used at any one time, per networked system.

If you have more than one Quantum™ Radar scanner installed on your vessel and want to use them at the same time, the multifunction displays to which the scanners are connected must NOT be networked together. This applies to Quantum™ scanners connected either wired or wirelessly.

Chapter 3: Planning the installation

Chapter contents

- [3.1 Installation checklist on page 16](#)
- [3.2 Required additional components on page 16](#)
- [3.3 Multifunction display compatibility on page 17](#)
- [3.4 Multifunction display software requirements on page 17](#)
- [3.5 Tools required on page 18](#)
- [3.6 Typical systems on page 18](#)
- [3.7 Location requirements on page 19](#)
- [3.8 Product dimensions on page 20](#)

3.1 Installation checklist

Installation includes the following activities:

Installation Task	
1	Plan your system.
2	Obtain all required equipment and tools.
3	Site all equipment.
4	Route all cables.
5	Drill cable and mounting holes.
6	Make all connections into equipment.
7	Secure all equipment in place.
8	Power on and test the system.

Schematic diagram

A schematic diagram is an essential part of planning any installation. It is also useful for any future additions or maintenance of the system. The diagram should include:

- Location of all components.
- Connectors, cable types, routes and lengths.

Warnings and cautions

Important: Before proceeding, ensure that you have read and understood the warnings and cautions provided in the [Chapter 1 Important information](#) section of this document.

3.2 Required additional components

This product forms part of a system of electronics and requires the following additional components for full operation.

- Compatible Raymarine multifunction display. Refer to [Compatible multifunction displays](#) for a list of compatible multifunction displays.
- Optional data cable. Refer to [Chapter 4 Cables and connections](#) for suitable cables and adaptors for existing cable installations. (The Quantum™ scanner is Wi-Fi-enabled, and can be operated without a fixed data cable.)

Operation instructions

For detailed operation instructions for your product, refer to the documentation that accompanies your display.

Retain your Wi-Fi passcode

To connect to the Radar using Wi-Fi (wireless), you will need to know the unit's **SSID**, and **Passcode** (password).

Both the SSID and Passcode are provided on the Radar scanner packaging, on the serial number label on the underside of the unit, on a label attached to the power cable and on spare serial number labels supplied in the box. You may wish to make a separate note of this information (kept in a secure location). You should also keep the Radar scanner packaging in a safe place for future reference.

3.3 Multifunction display compatibility

Compatible multifunction displays

This product is compatible with only LightHouse™-powered Raymarine multifunction displays.

LightHouse™ MFDs:

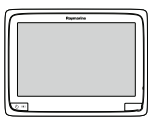
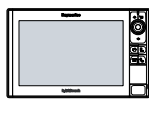
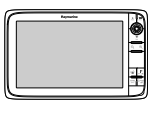
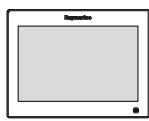
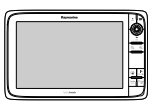
	Product variants		Product variants
	a Series		eS Series
	c Series		gS Series
	e Series		

Incompatible multifunction displays

This product is NOT compatible with the following legacy Raymarine multifunction displays.

Legacy MFDs

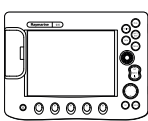
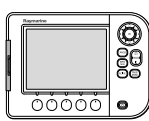
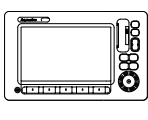
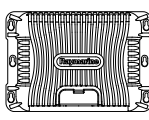
	Product variants		Product variants
	C-Series Classic C70, C80, C120 E-Series Classic E80, E120		A-Series Classic A50, A50D, A57D, A70, A70D
	C-Series Widescreen C90W, C120W, C140W E-Series Widescreen E90W, E120W, E140W		G-Series GPM400

3.4 Multifunction display software requirements

The operation of this product requires that your Raymarine LightHouse™-powered MFD is running LightHouse™ software version 16 or later.

Note: The latest MFD software can be obtained by visiting www.raymarine.com/software.

Caution: Installing software updates

The software update process is carried out at your own risk. Before initiating the update process ensure you have backed up any important files.

Ensure that the unit has a reliable power supply and that the update process is not interrupted.

Damage caused by incomplete updates are not covered by Raymarine warranty.

By downloading the software update package, you agree to these terms.

Software updates

The software running on the product can be updated.

- Raymarine periodically releases software updates to improve product performance and add new features.
- You can update the software for your product using a connected and compatible multifunction display.
- Refer to www.raymarine.com/software/ for the latest software updates and the software update procedure for your product.
- If in doubt as to the correct procedure for updating your product software, refer to your dealer or Raymarine technical support.

3.5 Tools required

Product installation requires the following tools:

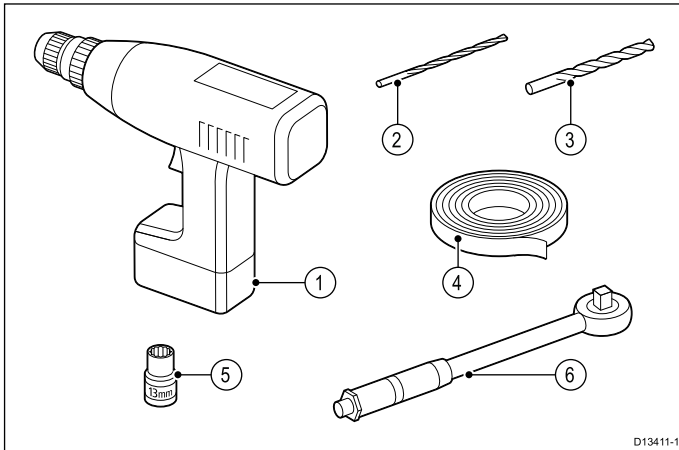

Item number	Description	Quantity
1	Power drill	1
2	3 mm drill bit	1
3	10 mm drill bit	1
4	Adhesive tape	1
5	13 mm socket	1
6	Torque wrench	1

3.6 Typical systems

Note: The following illustrations show the various products that can be connected in a typical system.

- For information on how to connect the products, refer to the [Chapter 4 Cables and connections](#) section.
- For information on available cables and accessories, refer to the [Chapter 10 Spares and accessories](#) section.

Example: basic Radar system (wired data connection)

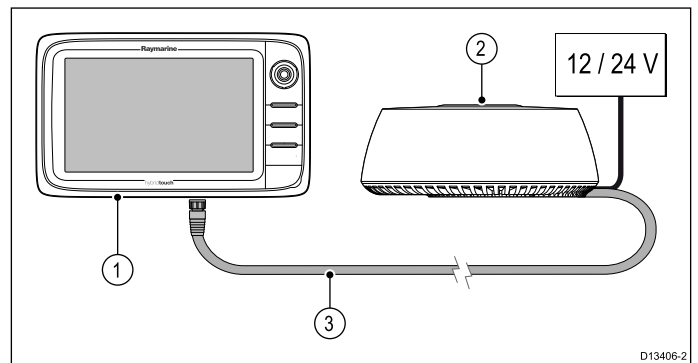

Item	Description
1	Multifunction display
2	Quantum™ Radome
3	RayNet data cable

Example: basic Radar system (wireless data connection)

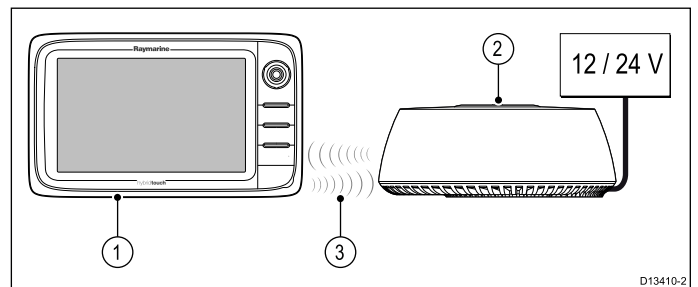

Item	Description
1	Multifunction display
2	Quantum™ Radome
3	Wi-Fi datalink

Example: expanded system (power cables not shown)

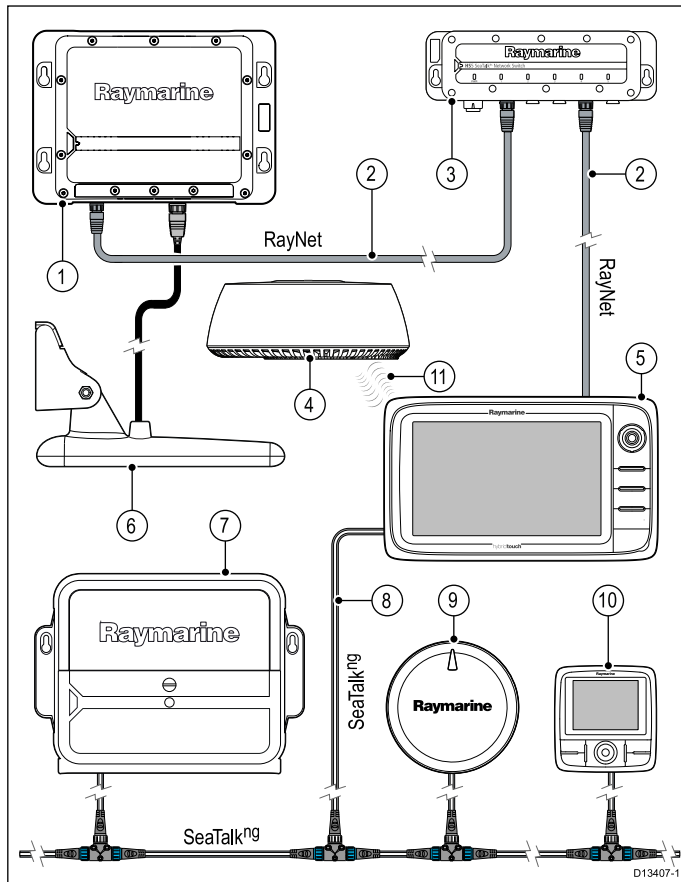

Item	Description
1	Sonar module
2	RayNet cables
3	RayNet network switch
4	Quantum™ Radome
5	Multifunction display
6	DownVision transducer
7	Evolution ACU
8	SeaTalkng spur cable
9	Evolution EV
10	Pilot head controller
11	Wi-Fi datalink

3.7 Location requirements

The optimum height for the Quantum™ scanner is a location that is high enough above the waterline to give a long range line-of-sight to the horizon, but not so high as to be adversely affected by the boat's pitching and rolling.

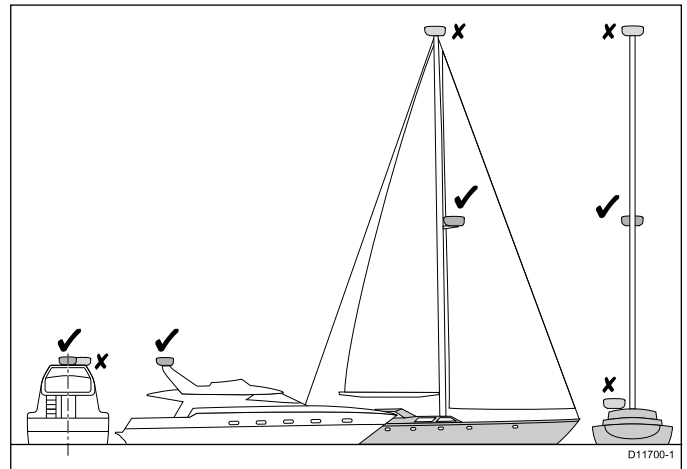

The scanner must also be mounted where it is:

- Above head height.
- Easily accessible.
- As near as possible to the boat's centerline.
- On a rigid and stable platform, capable of securely supporting the scanner under seagoing conditions.
- Clear of large objects such as the flybridge, large engine stacks, searchlights, horns, masts etc. (see [Shadow areas and false echoes](#) for additional information)
- Clear of heat and fumes.
- At least 1 m (3 ft) from a magnetic compass or other scanners.

Shadow areas and false echoes

Mount the Radar scanner away from large structures or equipment, such as engine stacks, searchlights, horns, or masts. These objects may cause shadow areas and false echoes. For example, if you mount the Radar scanner on a mast, echoes from other targets may be reflected from the mast. Wet sails may also cause shadow areas, so Radar performance may be reduced in the rain. It is particularly important to avoid shadow areas near the bow. Raising or even lowering the Radar scanner may help to reduce these effects.

In shadow areas beyond the obstruction there will be a reduction of the beam intensity. There may be a blind sector if the beam intensity is not sufficient to obtain an echo from an object. This may occur even at close range. For this reason the angular width and relative bearing of any shadow area must be determined at installation.

You may be able to detect shadow areas or false echoes on your multifunction display. For example, sea clutter can be used as a good indicator of blind arcs. Dark sectors on the Radar display indicate

possible shadowed areas. This information should be posted near the display unit and operators must be alert for targets in these blind areas.

Radar scanner mounting angle

Ensure the Radar scanner rotates parallel to the water line.

The Radar beam from the Radar scanner is approximately 20° wide in the vertical direction, to give good target detection even when your vessel pitches and rolls.

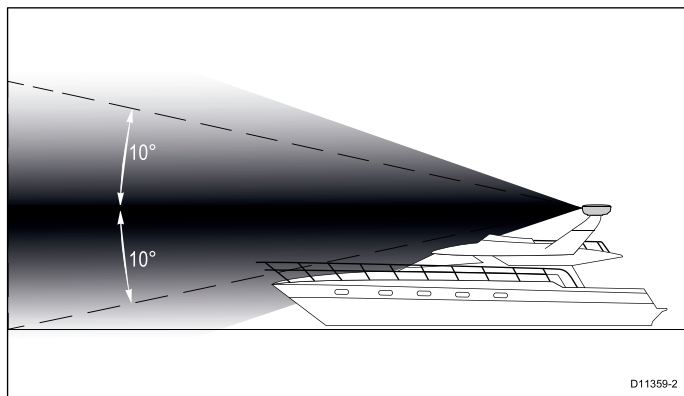

Planing hull vessels, and some displacement hull vessels, adopt a higher bow angle when the vessel is at cruising speed. This may raise the Radar's main radiation angle, and can cause poor detection of nearby targets. It may be necessary to compensate for the bow rise to ensure optimum target detection. This can be achieved by fitting a wedge or washers between the mounting platform and the base of the Radar scanner, so that the Radar beam remains parallel to the water line when the vessel's bow rises at cruising speed.

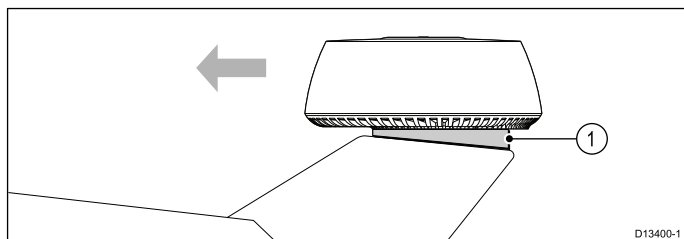

Item	Description
1	Wedge or washers

Multiple Radar scanners — location requirements

Important location considerations when installing multiple radar scanners on the same vessel.

- Scanners should be mounted above each other, vertically separated by at least 0.5 m (1.6 ft). This applies to all installation locations on the vessel.
- Multiple scanners should be mounted in a way that minimizes interference between the vertical beamwidths of the 2 scanners.
- In all cases, you should aim to achieve as much physical separation as possible, to minimize any potential interference.

3.8 Product dimensions

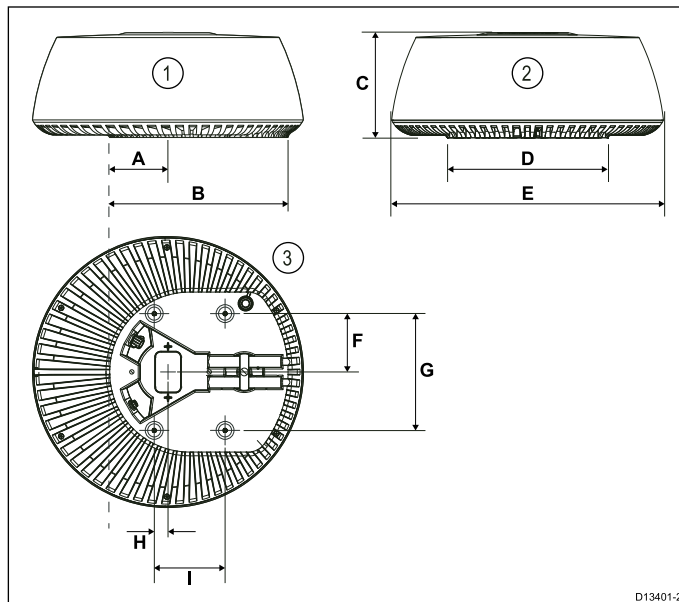

1. Side view of scanner.
2. Rear view of scanner.
3. Underside view of scanner.

Dimension	Measurement	Description
A	116.0 mm (4.57 in.)	Distance from centerline of scanner to front of mounting base.
B	355.0 mm (13.98 in.)	Distance from rear of mounting base to front of mounting base.
C	209.5 mm (8.25 in.)	Height of radar scanner.
D	319.5 mm (12.58 in.)	Mounting base width (rear of unit).
E	541.0 mm (21.30 in.)	Width of scanner.
F	116.5 mm (4.59 in.)	Distance from centerline to rear mounting hole.
G	233.0 mm (9.17 in.)	Distance between mounting holes.
H	27.5 mm (1.08 in.)	Distance from centerline to front mounting hole.
I	141.5 mm (5.57 in.)	Distance between front and rear mounting holes.

Chapter 4: Cables and connections

Chapter contents

- [4.1 General cabling guidance on page 22](#)
- [4.2 Connections overview on page 23](#)
- [4.3 Power connection on page 25](#)
- [4.4 Network connection on page 27](#)

4.1 General cabling guidance

Cable types and length

It is important to use cables of the appropriate type and length

- Unless otherwise stated use only standard cables of the correct type, supplied by Raymarine.
- Ensure that any non-Raymarine cables are of the correct quality and gauge. For example, longer power cable runs may require larger wire gauges to minimize voltage drop along the run.

Routing cables

Cables must be routed correctly, to maximize performance and prolong cable life.

- Do NOT bend cables excessively. Wherever possible, ensure a minimum bend diameter of 200 mm (8 in) / minimum bend radius of 100 mm (4 in).

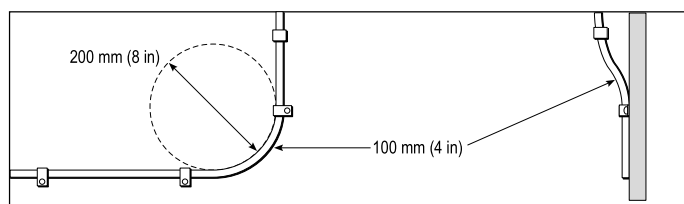

- Protect all cables from physical damage and exposure to heat. Use trunking or conduit where possible. Do NOT run cables through bilges or doorways, or close to moving or hot objects.
- Secure cables in place using tie-wraps or lacing twine. Coil any extra cable and tie it out of the way.
- Where a cable passes through an exposed bulkhead or deckhead, use a suitable watertight feed-through.
- Do NOT run cables near to engines or fluorescent lights.

Always route data cables as far away as possible from:

- other equipment and cables,
- high current carrying AC and DC power lines,
- antennae.

Strain relief

Ensure adequate strain relief is provided. Protect connectors from strain and ensure they will not pull out under extreme sea conditions.

Circuit isolation

Appropriate circuit isolation is required for installations using both AC and DC current:

- Always use isolating transformers or a separate power-inverter to run PC's, processors, displays and other sensitive electronic instruments or devices.
- Always use an isolating transformer with Weather FAX audio cables.
- Always use an isolated power supply when using a 3rd party audio amplifier.

- Always use an RS232/NMEA converter with optical isolation on the signal lines.
- Always make sure that PC's or other sensitive electronic devices have a dedicated power circuit.

Cable shielding

Ensure that all data cables are properly shielded that the cable shielding is intact (e.g. hasn't been scraped off by being squeezed through a tight area).

Suppression ferrites

- Raymarine cables may be pre-fitted or supplied with suppression ferrites. These are important for correct EMC performance. If ferrites are supplied separately to the cables (i.e. not pre-fitted), you must fit the supplied ferrites, using the supplied instructions.
- If a ferrite has to be removed for any purpose (e.g. installation or maintenance), it must be replaced in the original position before the product is used.
- Use only ferrites of the correct type, supplied by Raymarine or its authorized dealers.
- Where an installation requires multiple ferrites to be added to a cable, additional cable clips should be used to prevent stress on the connectors due to the extra weight of the cable.

4.2 Connections overview

Use the following information to help you identify the connections on your product.

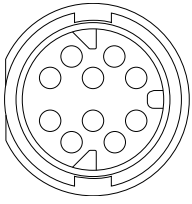
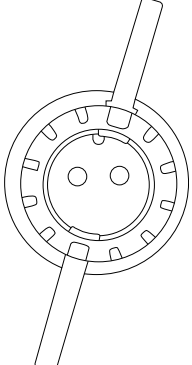
Connector	Connects to:	Suitable cables
	RayNet network or device. Not required if connecting using Wi-Fi.	Refer to the Chapter 10 Spares and accessories section.
	12 V / 24 V power supply.	Supplied with your product.

The power and data connections are located on the underside of the scanner unit, as shown in the following illustration.

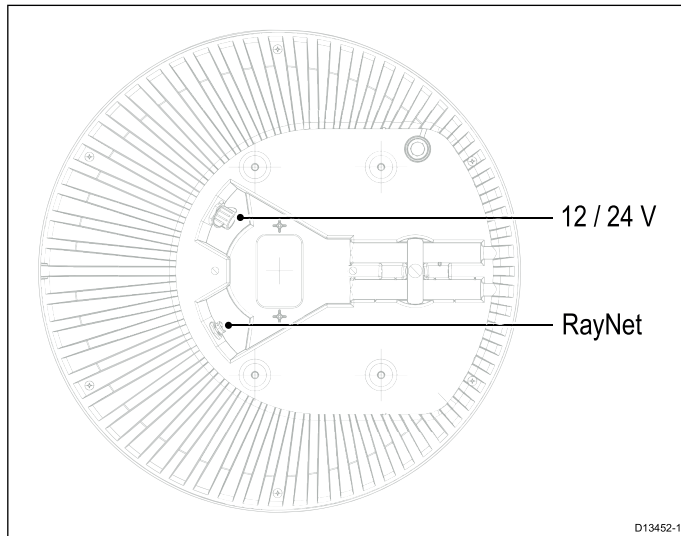

Typical cable routing scenarios

There are 4 typical cable routing scenarios.

Note: The routing options described and illustrated in this section assume that a physical data connection is used between your Radar scanner and multifunction display (MFD). However, if the scanner is connected to your MFD via Wi-Fi, a physical RayNet connection is not required.

1. Cable routing for a scanner mounted on a platform, using separate cables for the power and data connection.
2. Cable routing for a scanner mounted on a platform, using the combined power and data cable from an existing Raymarine Digital Radar scanner installation. For this, the **A80308** Y-adapter accessory is required (not supplied with the scanner).

3. Cable routing for a scanner mounted on a pole, using separate cables for the power and data connection.
4. Cable routing for a scanner mounted on a pole, using the combined power and data cable from an existing Raymarine Digital Radar scanner installation. For this, the **A80308** Y-adapter accessory is required (not supplied with the scanner).

Cable routing — platform mount

There are 2 typical cable routing scenarios for platform mount installations.

- Using separate power and data cables.
- Using an existing combined power / data cable from an older Raymarine Digital radar scanner. In this scenario, the **A80308** Y-adapter accessory is required (not supplied with the scanner).

Using separate power and data cables

Note: The routing options described and illustrated in this section assume that a physical data connection is used between your Radar scanner and multifunction display (MFD). However, if the scanner is connected to your MFD via Wi-Fi, a physical RayNet connection is not required.

The following drawing illustrates the cable routing for a scanner mounted on a platform, using separate cables for the power and data connections.

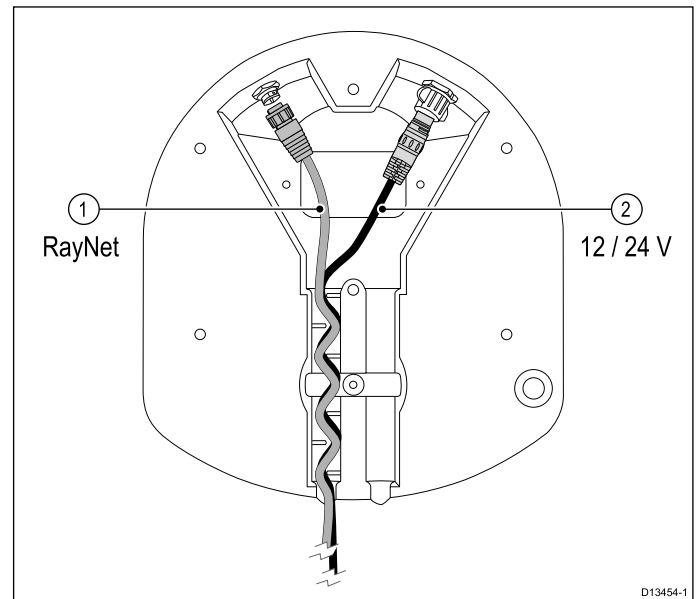

1. RayNet data connection.
2. 12 V / 24 V power connection.

Note:

- A separate power cable is supplied with all Quantum™ Radar variants.
- Not all Quantum™ radar variants are supplied with a RayNet cable. Refer to the [Chapter 2 Document and product information](#) section for more information.
- Refer to the [10.4 RayNet to RayNet cables and connectors](#) section for information on suitable accessory RayNet cables.

Using an existing combined power / data cable from an older Raymarine Digital Radar

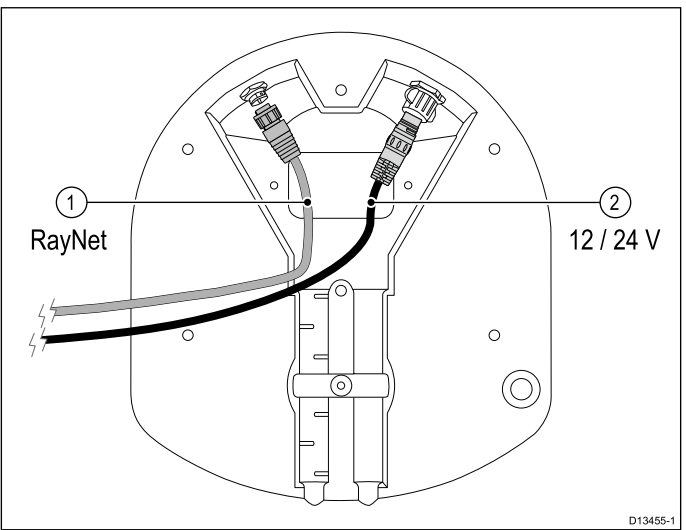
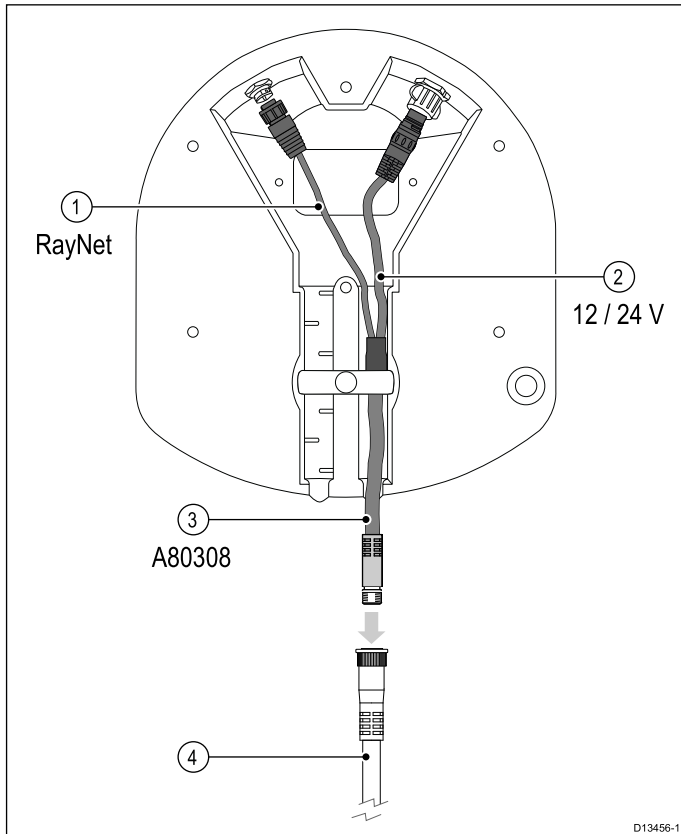

1. RayNet data connection.
2. 12 V / 24 V power connection.

Note:

- A separate power cable is supplied with all Quantum™ Radar variants.
- Not all Quantum™ radar variants are supplied with a RayNet cable. Refer to the [Chapter 2 Document and product information](#) section for more information.
- Refer to the [10.4 RayNet to RayNet cables and connectors](#) section for information on suitable accessory RayNet cables.

Note: The Y-adapter cable is actually white. For clarity, it is shown in the above drawing in different colors.

1. RayNet data connection. This cable is part of the **A80308** Y-adapter accessory cable.
2. 12 V / 24 V power connection. This cable is part of the **A80308** Y-adapter accessory cable.
3. **A80308** Y-adapter accessory cable (not supplied with the scanner).
4. Existing combined Digital Radar power / data cable.

Using an existing combined power / data cable from an older Raymarine Digital Radar

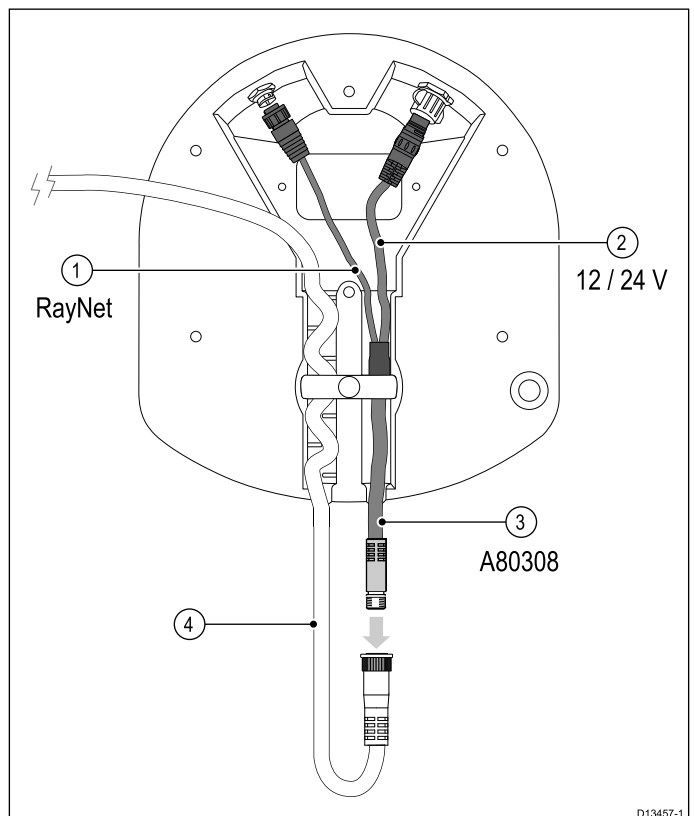

Cable routing — pole mount

There are 2 typical cable routing scenarios for pole mount installations.

- Using separate power and data cables.
- Using an existing combined power / data cable from an older Raymarine Digital Radar scanner. In this scenario, the **A80308** Y-adapter accessory is required (not supplied with the scanner).

Using separate power and data cables

Note: The routing options described and illustrated in this section assume that a physical data connection is used between your Radar scanner and multifunction display (MFD). However, if the scanner is connected to your MFD via Wi-Fi, a physical RayNet connection is not required.

The following drawing illustrates the cable routing for a scanner mounted on a platform, using separate cables for the power and data connection.

Note: The Y-adapter cable is actually white. For clarity, it is shown in the above drawing in different colors.

1. RayNet data connection. This cable is part of the **A80308** Y-adapter accessory cable.
2. 12 V / 24 V power connection. This cable is part of the **A80308** Y-adapter accessory cable.
3. **A80308** Y-adapter accessory cable (not supplied with the scanner).
4. Existing combined Digital Radar power / data cable.

Making connections

Follow the steps below to connect the cable(s) to your product. If you intend to use the scanner's Wi-Fi functionality to connect to your multifunction display, you need only connect a power cable to the scanner.

Note: If your vessel is already fitted with a combined power / data Digital Radar cable, you can use a Y-adapter (part number A80308) to connect the existing cable-end to the scanner's connectors.

1. Ensure that the vessel's power supply is switched off.
2. Ensure that the multifunction display being connected to the scanner has been installed in accordance with the installation instructions supplied with that device.
3. Ensure the power connector locking collar on the scanner is in the unlocked position.
4. Route the power cable and optional data cable within the scanner base, as shown in the cable routing illustrations in this section. Cable routing depends on whether you mount the scanner on a platform or on a pole, and on whether you are using a Y-adapter to connect to an existing combined power / data Digital Radar cable.
5. Ensure that the power cable connector is orientated so that the notch lines up with the guide in the connector.
6. Push the power cable connector all the way into the scanner's power connector.
7. Rotate the locking collar clockwise until it is in the locked position (2 clicks).
8. Push the optional data cable fully onto the corresponding connector on the scanner.
9. If you are using a Y-adapter, make the final connection between the adapter and the existing combined power / data Digital Radar cable.

4.3 Power connection

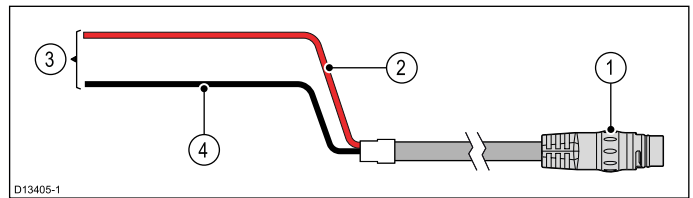

Note: A Y-adapter cable (part number A80308) is available for existing installations that already use a combined power/data cable from a Digital or HD Color Radome. The Y-adapter splits the existing combined cable into the separate data and power connectors used by the scanner.

Item	Description	Connects to:
1	Power cable.	Product's power connector.
2	Red cable (positive)	Power supply's positive terminal.
3	Connection to 12 V / 24 V power supply.	Power supply.
4	Black cable (negative)	Power supply's negative terminal.

In-line fuse and thermal breaker ratings

The following in-line fuse and thermal breaker ratings apply to your product:

In-line fuse rating	Thermal breaker rating
5 A	3 A (if only connecting one device)

Note:

- The suitable fuse rating for the thermal breaker is dependent on the number of devices you are connecting. If in doubt consult an authorized Raymarine dealer.
- Your product's power cable may have a fitted in-line fuse, if not then you must add an in-line fuse / breaker to the positive wire of your products power connection.



Warning: Grounding not required

This product is fully insulated and does NOT require separate grounding.

Power cable extension

The product is supplied with a power cable, which can be extended if required.

- The power cable for each unit in your system should be run as a separate, single length of 2-wire cable from the unit to the vessel's battery or distribution panel.
- Raymarine recommends a **minimum** wire gauge of 14AWG (2.08 mm²) for any length of cable extension.
- For all lengths of extension to the power cable, ensure there is a continuous **minimum** voltage

at the product's power connector of 10.8 V with a fully flat battery at 11 V.

Important: Be aware that some products in your system (such as sonar modules) can create voltage peaks at certain times, which may impact the voltage available to other products during the peaks.

Power distribution

Recommendations and best practice.

- The product is supplied with a power cable. Only use the power cable supplied with the product. Do NOT use a power cable designed for, or supplied with, a different product.
- Refer to the *Power connection* section for more information on how to identify the wires in your product's power cable, and where to connect them.
- See below for more information on implementation for some common power distribution scenarios.

Important: When planning and wiring, take into consideration other products in your system, some of which (e.g. sonar modules) may place large power demand peaks on the vessel's electrical system.

Note: The information provided below is for guidance only, to help protect your product. It covers common vessel power arrangements, but does NOT cover every scenario. If you are unsure how to provide the correct level of protection, please consult an authorized Raymarine dealer or a suitably qualified professional marine electrician.

Implementation — direct connection to battery

- The power cable supplied with your product may be connected directly to the vessel's battery, via a suitably rated fuse or breaker.
- The power cable supplied with your product may NOT include a separate drain wire. If this is the case, only the power cable's red and black wires need to be connected.
- If the supplied power cable is NOT fitted with an inline fuse, you MUST fit a suitably rated fuse or breaker between the red wire and the battery's positive terminal.
- Refer to the inline fuse ratings provided in the product's documentation.
- If you need to extend the length of the power cable supplied with your product, ensure you observe the dedicated *Power cable extensions* advice provided in the product's documentation.

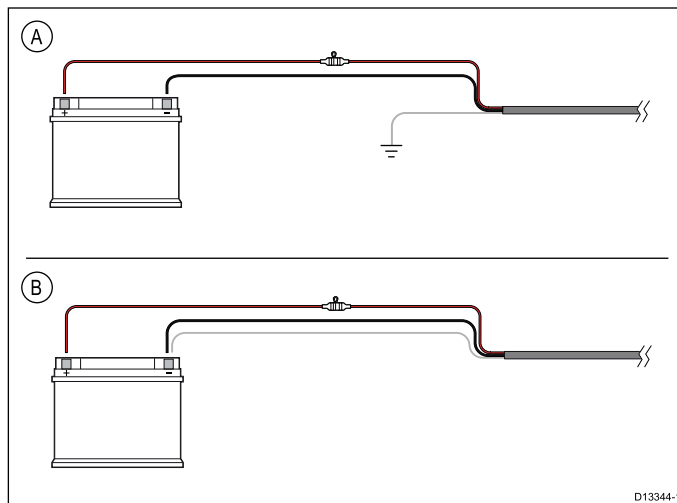

A	Battery connection scenario A: suitable for a vessel with a common RF ground point. In this scenario, if your product's power cable is supplied with a separate drain wire then it should be connected to the vessel's common ground point.
B	Battery connection scenario B: suitable for a vessel without a common grounding point. In this case, if your product's power cable is supplied with a separate drain wire then it should be connected directly to the battery's negative terminal.

Implementation — connection to distribution panel

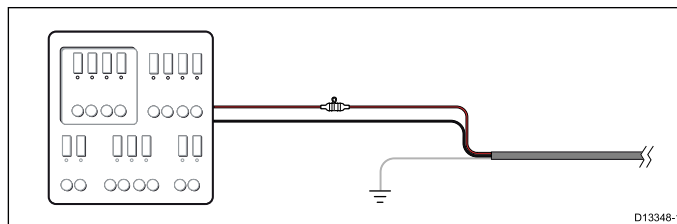

- Alternatively, the supplied power cable may be connected to a suitable breaker or switch on the vessel's distribution panel or factory-fitted power distribution point.
- The distribution point should be fed from the vessel's primary power source by 8 AWG (8.36 mm²) cable.
- Ideally, all equipment should be wired to individual suitably-rated thermal breakers or fuses, with appropriate circuit protection. Where this is not possible and more than 1 item of equipment shares a breaker, use individual in-line fuses for each power circuit to provide the necessary protection.
- In all cases, observe the recommended breaker / fuse ratings provided in the product's documentation.
- If you need to extend the length of the power cable supplied with your product, ensure you observe the dedicated *Power cable extensions* advice provided in the product's documentation.

Important: Be aware that the suitable fuse rating for the thermal breaker or fuse is dependent on the number of devices you are connecting.

Grounding

Ensure that you observe the separate grounding advice provided in the product's documentation.

More information

Raymarine recommends that best practice is observed in all vessel electrical installations, as detailed in the following standards:

- BMEA Code of Practice for Electrical and Electronic Installations in Boats
- NMEA 0400 Installation Standard
- ABYC E-11 AC & DC Electrical Systems on Boats
- ABYC A-31 Battery chargers and Inverters
- ABYC TE-4 Lightning Protection



Warning: Grounding not required

This product is fully insulated and does NOT require separate grounding.

4.4 Network connection

The scanner must be connected to a compatible Raymarine multifunction display, either via Wi-Fi, or via a physical RayNet cable connection. Once connected, the multifunction display can show Radar echo data.

Wired (RayNet) multifunction display connection

Scanner connected to a multifunction display using a RayNet cable.

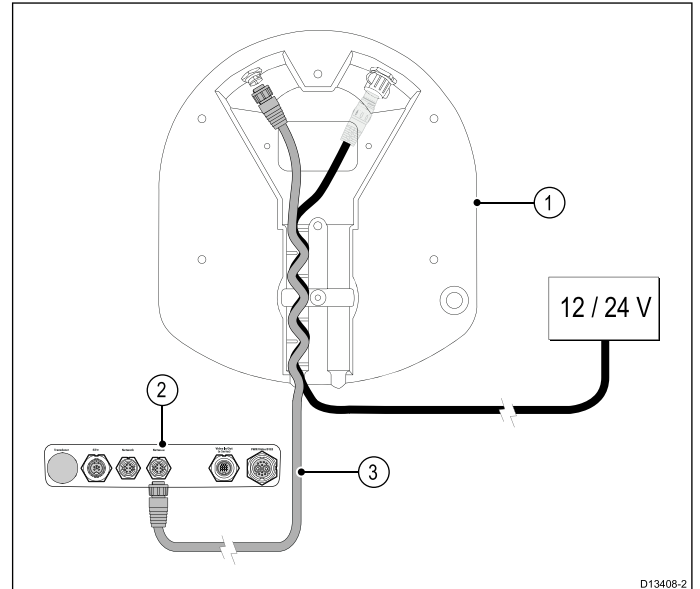

Item	Description
1	Quantum™ Radome (for clarity, only the connections area of the underside of the unit is shown here).
2	Connector panel of compatible Raymarine multifunction display.
3	RayNet data cable.

Wi-Fi multifunction display connection

Scanner connected to a multifunction display using Wi-Fi.

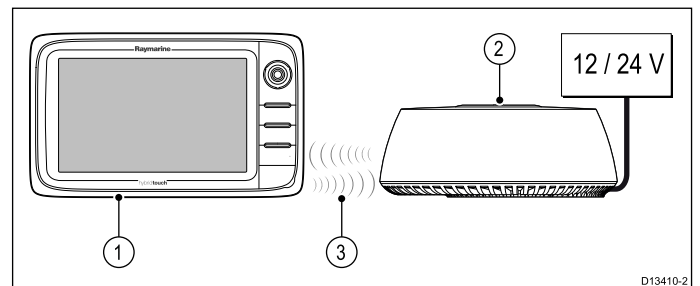

Item	Description
1	Compatible Raymarine multifunction display with Wi-Fi capability.
2	Quantum™ Radome.
3	Wi-Fi datalink.

Refer to the [Switch on and initial setup](#) section, and to your MFD documentation for further information about setting up the Wi-Fi connection between your MFD and the Quantum™ scanner.

Multiple multifunction display configuration

A Raymarine network switch can be used to connect the unit to more than 1 multifunction display.

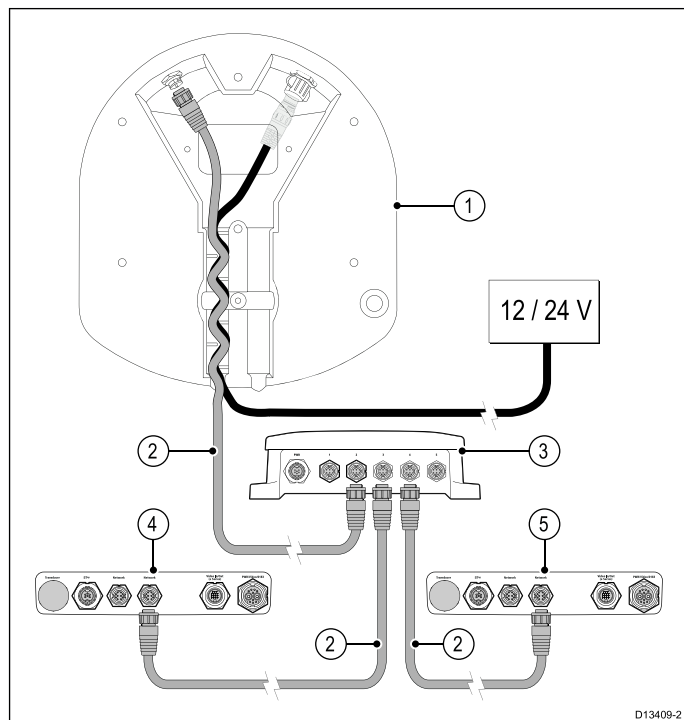

D13408-2

Item	Description
1	Quantum™ radome (for clarity, only the connections area of the underside of the unit is shown here).
2	RayNet cable.
3	RayNet network switch.
4	Connector panel of compatible Raymarine multifunction display.
5	Connector panel of additional compatible Raymarine multifunction display.

For details on available network hardware and cables refer to [Chapter 10 Spares and accessories](#).

Chapter 5: Mounting

Chapter contents

- [5.1 Mounting the scanner on page 30](#)
- [5.2 Radar scanner protection — sailing vessels on page 31](#)

5.1 Mounting the scanner

Use a mounting location that:

- Is robust enough to support the Quantum™ scanner, under seagoing conditions.
- Meets the requirements described under *Scanner Position*

Then:

1. Tape the template to the mounting platform, ensuring that the arrow on the template is pointed towards the front of the vessel.

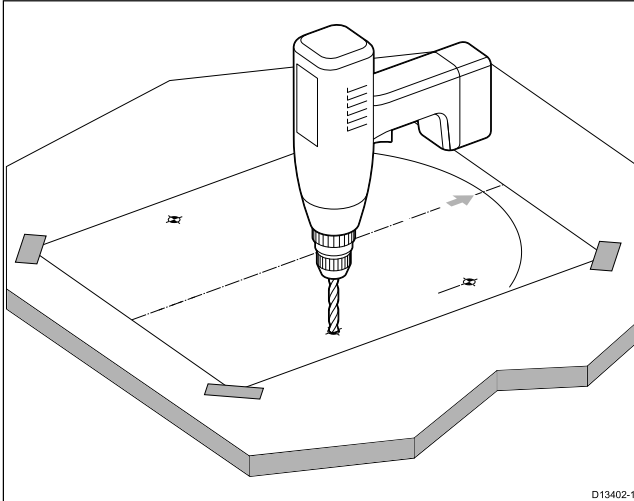

2. Drill 3 mm pilot holes in the four positions shown on the template.
3. Drill out the pilot holes to 10 mm diameter.
4. Place the Quantum™ scanner in position. If you are fitting it on a planing vessel, shim the rear of the scanner, so that the beam points slightly down in the forward direction when the boat is at rest, to compensate for the bow rising at cruising speed

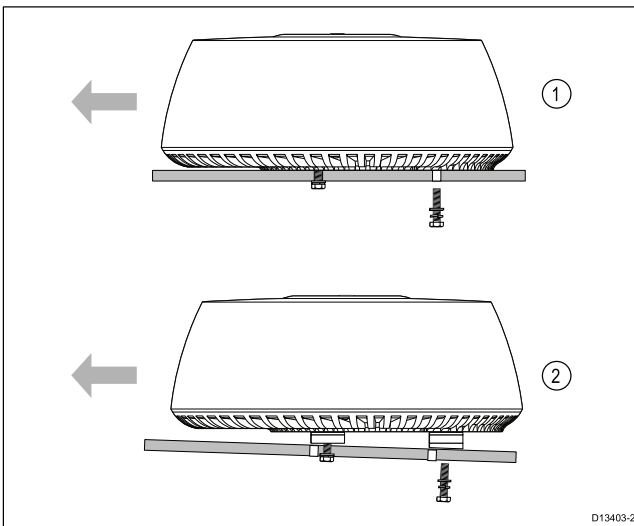

Item	Description
1	Mounting platform, non-planing boat (level install)
2	Mounting platform, planing boat (typical planing angle shown)

5. Before securing the scanner to the mounting platform, connect the power cable (and optionally a data cable), ensuring that all cables are routed appropriately. See the [4.2 Connections overview](#) section for further information about making connections, and cable routing.

6. Ensuring that the bolts do not enter the scanner base more than 25 mm (1 inch), secure the scanner with the 4 bolts, flat washers and spring washers provided, as illustrated. If necessary, use appropriate shims or extra washers to limit the length of bolt entering the scanner base.

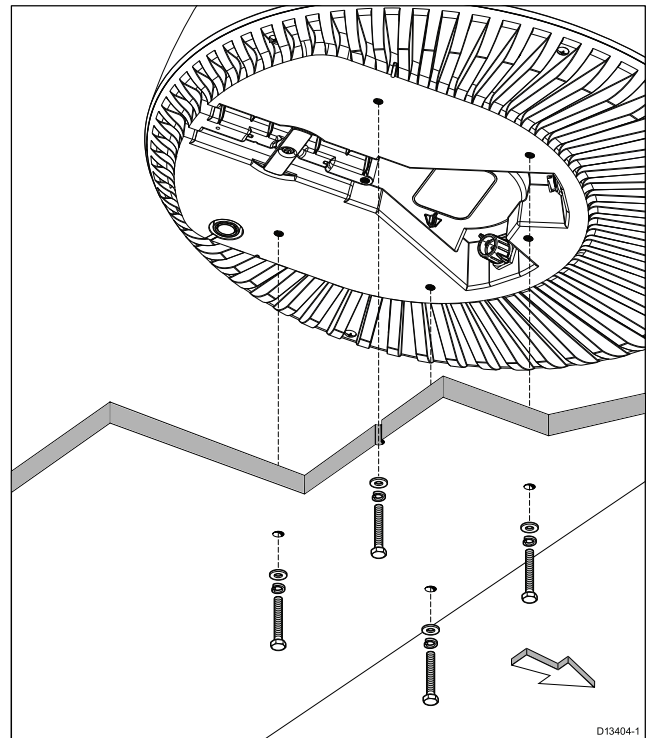

7. Tighten the bolts to a torque of 15 Nm (133 lbf/inch).
8. Attach a safety lanyard (not supplied) to your vessel, and secure the free end to the scanner using the attachment point shown in the following illustration:

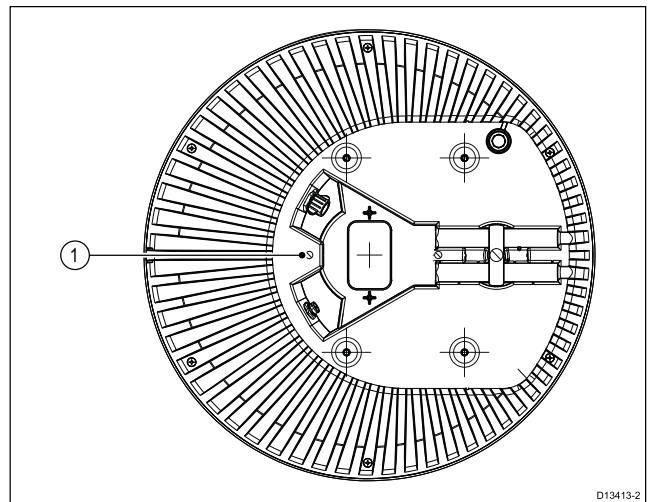

Item	Description
1	Safety lanyard attachment point.

Note: If you are installing the Radar scanner on a sailing vessel, additional protection for the Radar scanner may be required. Refer to [5.2 Radar scanner protection — sailing vessels](#).

Multiple Quantum™ Radar scanners

Only 1 (one) Quantum™ Radar scanner can be used at any one time, per networked system.

If you have more than one Quantum™ Radar scanner installed on your vessel and want to use them at the same time, the multifunction displays to which the scanners are connected must NOT be networked together. This applies to Quantum™ scanners connected either wired or wirelessly.

Multiple Radar scanners — location requirements

Important location considerations when installing multiple radar scanners on the same vessel.

- Scanners should be mounted above each other, vertically separated by at least 0.5 m (1.6 ft). This applies to all installation locations on the vessel.
- Multiple scanners should be mounted in a way that minimizes interference between the vertical beamwidths of the 2 scanners.
- In all cases, you should aim to achieve as much physical separation as possible, to minimize any potential interference.

5.2 Radar scanner protection — sailing vessels

Additional considerations apply when installing the Radar scanner on a sailing vessel.

- When mounting the Radar scanner unit onto the mast, check that the unit is not fouled by the sails, especially when tacking.
- Depending on the type of sailing vessel and the design of the sailplan, a Radar scanner guard should be attached to the mast if the sails or rigging contact either the Radar scanner unit or the mounting bracket. Without a proper Radar guard, serious damage can result to the Radar mounting bracket and the Radar itself. In extreme cases, such damage could result in the Radar scanner unit being pulled off the mast. Therefore, it is recommended that a Radar scanner guard should be mounted additionally and separately to the Radar scanner mounting bracket.
- To prevent the risk of the Radar scanner unit falling after it has been damaged, the security lanyard supplied with the mast bracket MUST be secured properly to the mast and to the Radar scanner unit, according to the instructions provided with the bracket. If a safety lanyard is not supplied with the mounting bracket, contact your local dealer for appropriate parts. Do NOT attach other equipment to either the Radar scanner unit or the bracket.
- Raymarine strongly recommends that you check the condition and security of the bracket mounting feet, the security lanyard(s), the Radar scanner guard, and the Radar scanner unit itself, on a yearly basis (or more frequently depending on environmental applications). Any fittings should be replaced as appropriate.

The following illustration shows an example of an installation featuring a Radar scanner fitted to a typical mounting bracket, a Radar guard attached to the mast (separately to the Radar mounting bracket), and safety lanyards:

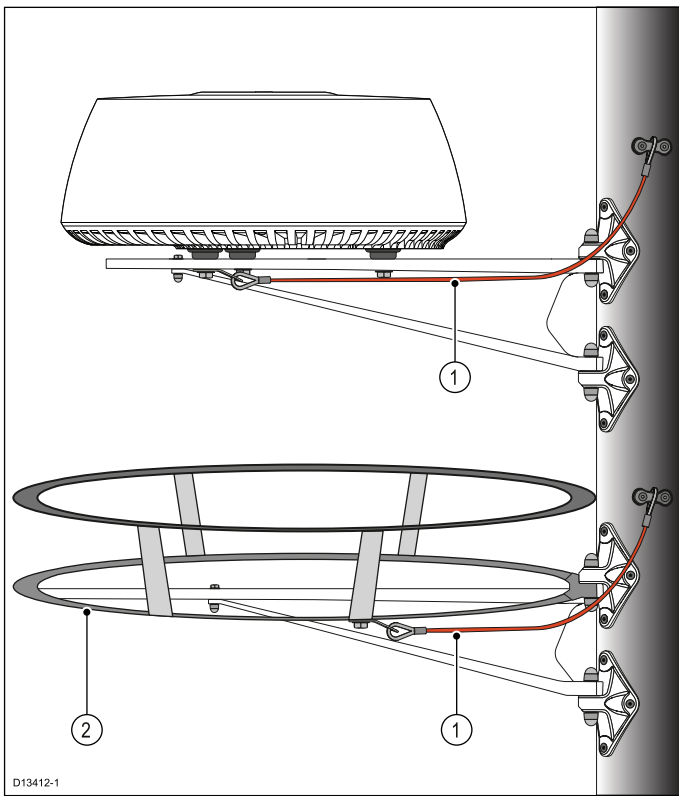

1. Example of a typical safety lanyard.
2. Example of a typical Radar scanner guard, attached to the mast independently of the Radar mounting bracket.

Note: The Radar guard shown in the illustration above is provided as an example only. The exact design and positioning of the Radar guard is wholly dependent on the nature of your vessel, sailplan, and installation environment. For example, for some vessels it is appropriate to locate the guard above the Radar scanner; for other vessels, it may be more appropriate to fit it below the scanner. Raymarine does not supply Radar guards but recommends that you select a guard that is attached directly to the mast and is completely separate to the Radar mounting bracket. It may be necessary to have a Radar guard custom designed to suit your specific vessel and installation environment. Please contact your local dealer for further advice.

Chapter 6: System checks and troubleshooting

Chapter contents

- [6.1 Post installation procedures on page 34](#)
- [6.2 Troubleshooting on page 35](#)

6.1 Post installation procedures

Before using the product, carry out the following:

- Mechanical checks.
- Switch on and initial setup.

Mechanical checks

Before switching on the product:

- Ensure that:
 - All securing bolts are fully tightened and the appropriate mechanical locking washers are in place.
 - All connections are securely made.
 - All connecting cables and wires are secured and protected as necessary.
- Ask your local Raymarine authorized installer to check the installation.

Switch on and initial setup

Use the information given here in conjunction with the detailed information in your multifunction display (MFD) documentation, to switch on and connect to the Quantum™ scanner, and to carry out the initial checks and setup tasks.

1. Power on your multifunction display (MFD) unit.
2. If you intend to make a wireless connection to the Quantum™ scanner, ensure that your MFD unit supports Wi-Fi, and that Wi-Fi connectivity is enabled on the unit.
3. To connect your MFD unit to the Quantum™ scanner:
 - i. To make a Wi-Fi connection, open the Connect to Quantum Radar screen on your MFD: **Menu > Set-up > System settings > External Devices > Quantum Radar > Pair with Quantum Radar.**

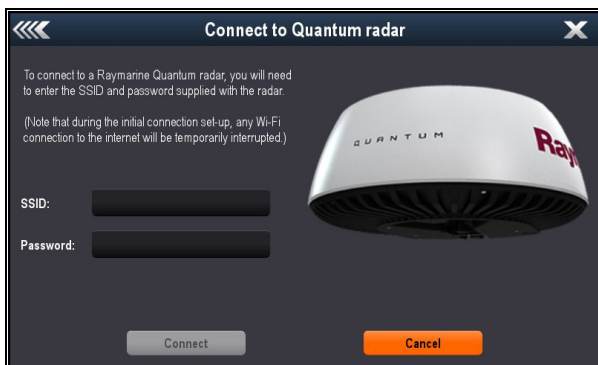

Enter the SSID and Password for your scanner, then select **Connect**.

Note: The SSID and Wi-Fi passcode are provided on the box that the scanner was packed in, and also on the serial number-label fixed to the underside of the scanner.

Note: It can take up to 2 minutes to make the Wi-Fi connection to the scanner.

- ii. For a wired connection, open the Radar application on your MFD unit. If the Radar scanner is not in standby, a dialog will be

displayed. You will then need to select the Power **On** option to place the scanner into Standby. The display will then indicate when the connection to the Quantum™ scanner has been made. The **Power up Radar** option is also accessible by momentarily pressing the MFD's Power button.

Note: If the connection to the MFD is lost while the scanner is in Standby mode, the scanner will switch to Sleep mode within 30 minutes. When the connection to the MFD is restored, return the scanner to Standby mode using the **Power up Radar** option on the MFD's Shortcut screen, accessible by momentarily pressing the MFD's Power button.

4. Ensure that all personnel are clear of the scanner, then switch the scanner to Transmit mode using the **Radar: Tx** option on the Shortcut screen, accessible on your MFD by momentarily pressing the MFD's power key.

Note: If the connection to the MFD is lost while the scanner is in Transmit mode, the scanner will switch to Standby mode within 5 seconds. When the connection to the MFD is restored, return the scanner to Transmit mode using the **Radar: Tx** option on the MFD's Shortcut screen.

5. Carry out the Radar operations described in the relevant MFD Operation handbook and check that all functions appear to be satisfactory.
6. Check the bearing alignment (as described in the MFD Operation handbook) to ensure that targets appear at their correct bearing relative to the boat's bow. Adjust the alignment as necessary.

Retain your Wi-Fi passcode

To connect to the Radar using Wi-Fi (wireless), you will need to know the unit's **SSID**, and **Passcode** (password).

Both the SSID and Passcode are provided on the Radar scanner packaging, on the serial number label on the underside of the unit, on a label attached to the power cable and on spare serial number labels supplied in the box. You may wish to make a separate note of this information (kept in a secure location). You should also keep the Radar scanner packaging in a safe place for future reference.

Operation instructions

For detailed operation instructions for your product, refer to the documentation that accompanies your display.

6.2 Troubleshooting

The troubleshooting information provides possible causes and corrective action required for common problems associated with marine electronics installations.

All Raymarine products are, prior to packing and shipping, subjected to comprehensive test and quality assurance programs. However, if you experience problems with the operation of your product this section will help you to diagnose and correct problems in order to restore normal operation.

If after referring to this section you are still having problems with your unit, please contact Raymarine Technical Support for further advice.

Troubleshooting procedure

Use the following table to identify problems and remedial actions.

Symptom	Action
No connection can be made to the scanner.	<p>Ensure the data cable (if used) is connected at both ends and is in good condition.</p> <p>If using a Wi-Fi (wireless) connection to the scanner unit, check that you have entered the correct Wi-Fi passcode for the SSID that matches your scanner. Both the SSID and Wi-Fi passcode are provided on the scanner packaging, and are also shown on the serial number label on the underside of the unit. Refer to your multifunction display (MFD) documentation for further information.</p> <p>If the scanner unit has shut down, awaken it by using the Power Up Radar option in the Shortcut screen, accessible on your MFD by momentarily pressing the MFD's power key. The Radar unit will shut down within 30 minutes if neither a wired (RayNet) connection, nor a wireless (Wi-Fi) connection can be made to a multifunction display unit (MFD).</p> <p>Ensure power supply thermal breaker has not tripped or fuse has not blown. If necessary, reset breaker or replace fuse ONCE ONLY. If breaker keeps tripping or fuse keeps blowing, contact a Raymarine authorized dealer for assistance.</p> <p>Ensure power supply maintains the correct voltage when the system is switched on.</p> <p>Ensure all products in the system have the correct software. Refer to www.raymarine.com/software/ for the latest software updates and the software update procedure for your product.</p> <p>If the Quantum™ Radome is connected to the multifunction display (MFD) via a SeaTalk^{hs} or RayNet network switch, ensure that:</p> <ul style="list-style-type: none">• All relevant equipment is correctly connected to the network switch.• The network switch power supply is satisfactory.• The network switch is in good condition.• Network cables are securely connected and in good condition.
Displayed bearing is different to the true bearing.	Carry out the bearing alignment procedure described in the MFD Operations manual.

Retain your Wi-Fi passcode

To connect to the Radar using Wi-Fi (wireless), you will need to know the unit's **SSID**, and **Passcode** (password).

Both the SSID and Passcode are provided on the Radar scanner packaging, on the serial number label on the underside of the unit, on a label attached to the power cable and on spare serial number labels supplied in the box. You may wish to make a separate note of this information (kept in a secure location). You should also keep the Radar scanner packaging in a safe place for future reference.

Chapter 7: Maintenance

Chapter contents

- [7.1 Maintenance on page 38](#)
- [7.2 Unit cleaning instructions on page 38](#)

7.1 Maintenance

Once a year:

1. Power-off the Radar.
2. Remove one of the antenna-securing bolts and associated washers.
3. Clean the bolt and washers.
4. Replace the bolt and associated washers.
5. Repeat steps 1 to 4 for all antenna-securing bolts.
6. Tighten all antenna-securing bolts to a torque of 15 Nm (133 lbf/inch).

Periodically, carry out these other maintenance tasks, with the Radar powered off:

- Ensure the antenna is firmly attached to the mounting surface.
- Check that any connected cables are in good condition and securely attached.
- Examine all cables for signs of chafing, cuts or other damage.



Warning: High voltages

This product may contain high voltages. Do NOT remove any covers or otherwise attempt to access internal components, unless specifically instructed in the documentation provided.

7.2 Unit cleaning instructions

The unit does not require regular cleaning. However, if you find it necessary to clean the unit, please follow the steps below:

1. Ensure power is switched off.
2. Wipe unit clean with a damp cloth.
3. If necessary, use a mild detergent solution to remove grease marks.

Chapter 8: Technical support

Chapter contents

- [8.1 Raymarine product support and servicing on page 40](#)
- [8.2 Operation instructions on page 41](#)
- [8.3 Viewing product information on page 41](#)

8.1 Raymarine product support and servicing

Raymarine provides a comprehensive product support service, as well as warranty, service, and repairs. You can access these services through the Raymarine website, telephone, and e-mail.

Product information

If you need to request service or support, please have the following information to hand:

- Product name.
- Product identity.
- Serial number.
- Software application version.
- System diagrams.

You can obtain this product information using the menus within your product.

Servicing and warranty

Raymarine offers dedicated service departments for warranty, service, and repairs.

Don't forget to visit the Raymarine website to register your product for extended warranty benefits: <http://www.raymarine.co.uk/display/?id=788>.

Region	Tele- phone	E-mail
United Kingdom (UK), EMEA, and Asia Pacific	+44 (0)1329 246 932	emea.service@raymarine.com
United States (US)	+1 (603) 324 7900	rm-usrepair@flir.com

Web support

Please visit the "Support" area of the Raymarine website for:

- **Manuals and Documents** — <http://www.raymarine.co.uk/display/?id=10125>
- **FAQ / Knowledgebase** — <http://www.raymarine.co.uk/knowledgebase/>
- **Technical support forum** — <http://raymarine.ning.com/>
- **Software updates** — <http://www.raymarine.com/software>

Telephone and e-mail support

Region	Tele- phone	E-mail
United Kingdom (UK), EMEA, and Asia Pacific	+44 (0)1329 246 777	support.uk@raymarine.com
United States (US)	+1 (603) 324 7900 (Toll-free: +800 539 5539)	support@raymarine.com

Region	Tele- phone	E-mail
Australia and New Zealand	+61 2 8977 0300	aus.support@raymarine.com (Raymarine subsidiary)
France	+33 (0)1 46 49 72 30	support.fr@raymarine.com (Raymarine subsidiary)
Germany	+49 (0)40 237 808 0	support.de@raymarine.com (Raymarine subsidiary)
Italy	+39 02 9945 1001	support.it@raymarine.com (Raymarine subsidiary)
Spain	+34 96 2965 102	sat@azimut.es (Authorized Raymarine distributor)
Netherlands	+31 (0)26 3614 905	support.nl@raymarine.com (Raymarine subsidiary)
Sweden	+46 (0)317 633 670	support.se@raymarine.com (Raymarine subsidiary)
Finland	+358 (0)207 619 937	support.fi@raymarine.com (Raymarine subsidiary)
Norway	+47 692 64 600	support.no@raymarine.com (Raymarine subsidiary)
Denmark	+45 437 164 64	support.dk@raymarine.com (Raymarine subsidiary)
Russia	+7 495 788 0508	info@mikstmarine.ru (Authorized Raymarine distributor)

8.2 Operation instructions

For detailed operation instructions for your product, refer to the documentation that accompanies your display.

8.3 Viewing product information

You can view information about your unit from the **Diagnostics** menu on a compatible multifunction display. This option displays information such as product serial number and software version.

With the Homescreen displayed:

1. Select **Set-up**.
2. Select **Maintenance**.
3. Select **Diagnostics**.
4. Select the **Select Device** option.
A list of connected devices is displayed.
5. Select the product for which you want to view information. Alternatively, select **Show All Data** to display information for all connected products.

Chapter 9: Technical specification

Chapter contents

- [9.1 Technical specification on page 44](#)

9.1 Technical specification

Approvals

Approvals:	Certification:
USA:	47CFR FCC Part 2 & Part 80 Certificate of Approval
Canada:	RSS238 Iss. 1 Technical Acceptance Certificate
European Union & EFTA:	R & TTE Directive 1999/05/EC Certificate of Opinion
Australia/New Zealand:	ACMA Declaration of Conformity Compliance level 3

General

Dimensions:	
Diameter:	541.0 mm
Height:	209.5 mm
Weight:	5.6 kg
Supply voltage:	Either 12 V dc or 24 V dc nominal Minimum: 10.8 V dc Maximum: 31.2 V dc
Power consumption:	Transmit mode (maximum): 17 W Standby mode: 7 W Sleep mode: 2 W
Environmental:	
Waterproof to:	IPX6
Operating temperature range:	-10°C to +55°C
Storage temperature range:	-25°C to +70°C
Additional storage conditions:	Store upright; do not block vents on underside
Humidity:	Up to 95% at 35°C
Maximum wind speed:	100 kts
Range scales:	1/16, 1/8, 1/4, 3/8, 1/2, 3/4, 1, 1.5, 2, 3, 4, 6, 8, 12, 16, and 24 nautical miles

Transmitter

Type:	X-band solid-state transmitter with pulse compression technology
Transmit frequency:	9354 MHz to 9446 MHz
Peak power output:	20 W
Duplexer:	Circulator
Pulse widths (3 dB):	40 ns to 14.7 μs
Chirp lengths:	400 ns to 22 μs
Pulse repetition frequency:	2083 Hz to 4167 Hz
Chirp bandwidth:	Up to 32 MHz
Standby mode:	Scanner rotation - OFF Scanner transmission - OFF Wi-Fi link - ON

Receiver

IF bandwidth:	26 MHz
Noise figure:	Less than 4 dB

Antenna

Type:	Phased array
Beamwidth (nominal)	Horizontal: 4.9° Vertical: 20°
Polarization:	Horizontal
Rotation speed:	24 rpm nominal

Chapter 10: Spares and accessories

Chapter contents

- 10.1 Quantum™ Radar accessories on page 46
- 10.2 Network hardware on page 46
- 10.3 Network cable connector types on page 47
- 10.4 **RayNet** to **RayNet** cables and connectors on page 48
- 10.5 RayNet to RJ45 adapter cables on page 49

10.1 Quantum™ Radar accessories

The following accessories are available for the Quantum™ Radar scanner:

Accessories

Item	Part number
10 m (32.8 ft.) Quantum™ power cable	A80309
5 m (16.4 ft.) Quantum™ data cable	A80274
10 m (32.8 ft.) Quantum™ data cable	A80275
15 m (49.2 ft.) Quantum™ data cable	A80310
25 m (82.0 ft.) Quantum™ data cable	A80311
Quantum™ Y-adapter cable	A80308
RayNet cable joiner	A80162

10.2 Network hardware

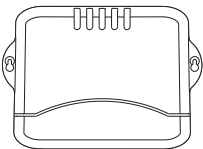
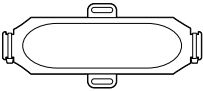
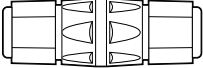
Item	Part number	Notes
HS5 RayNet network switch 	A80007	5-port switch for network connection of multiple devices featuring RayNet connectors. Equipment with RJ45 SeaTalk ^{hs} connectors can also be connected using suitable adapter cables.
RJ45 SeaTalk ^{hs} network switch 	E55058	8-port switch for network connection of multiple SeaTalk ^{hs} devices featuring RJ45 connectors.
RJ45 SeaTalk ^{hs} crossover coupler 	E55060	<ul style="list-style-type: none"> Enables direct connection of RJ45 SeaTalk^{hs} devices to smaller systems where a switch is not required. Enables the connection of RJ45 SeaTalk^{hs} devices to a HS5 RayNet network switch (in conjunction with suitable adapter cables). Enables 2 RJ45 SeaTalk^{hs} cables to be connected together to extend the length of the cabling. <p>Recommended for internal installations.</p> <div style="border: 1px solid black; padding: 5px;"> <p>Important: Do NOT use crossover devices for POE (Power Over Ethernet) connections.</p> </div>
Ethernet RJ45 coupler 	R32142	<ul style="list-style-type: none"> Enables direct connection of RJ45 SeaTalk^{hs} devices to smaller systems where a switch is not required. Enables the connection of RJ45 SeaTalk^{hs} devices to a HS5 RayNet network switch (in conjunction with suitable adapter cables). Enables 2 RJ45 SeaTalk^{hs} cables to be connected together to extend the length of the cabling. <p>Recommended for external installations.</p>

10.3 Network cable connector types

There are 2 types of network cable connector — RayNet, and RJ45 SeaTalk^{hs}.

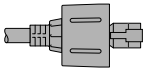
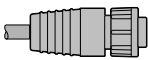
	RJ45 SeaTalk^{hs} connector.
	RayNet connector.

10.4 RayNet to RayNet cables and connectors

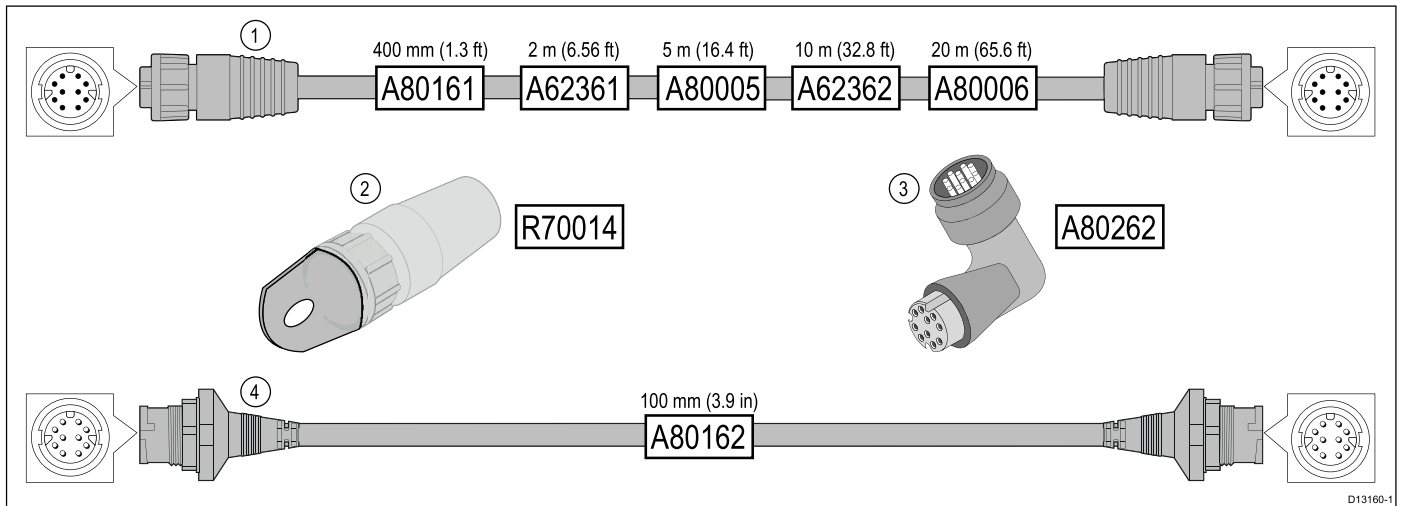

D13160-1

	Description	Typical use	Quantity
1	Standard RayNet connection cable with a RayNet (female) socket on both ends.	Suitable for connecting all RayNet equipment directly to LightHouse multifunction displays featuring a RayNet connector. Can also be used to connect RayNet equipment via a RayNet network switch (e.g. HS5).	1
2	RayNet cable puller (5 pack).	These “handles” securely attach to the twist-lock on RayNet cables, enabling you to pull the cables through conduits and other obstacles.	5
3	RayNet to RayNet right-angle coupler / adapter.	Suitable for connecting RayNet cables at 90° (right angle) to devices, for installations where space is limited. For example, use this adapter to connect a RayNet cable to a multifunction display when there is not enough space behind the display for the usual cable bend radius required by a standard RayNet cable. This adapter features a RayNet (female) socket at one end, and a RayNet (male) plug at the other end.	1
4	Adapter cable with a RayNet (male) plug on both ends.	Suitable for joining (female) RayNet cables together for longer cable runs.	1

10.5 RayNet to RJ45 adapter cables

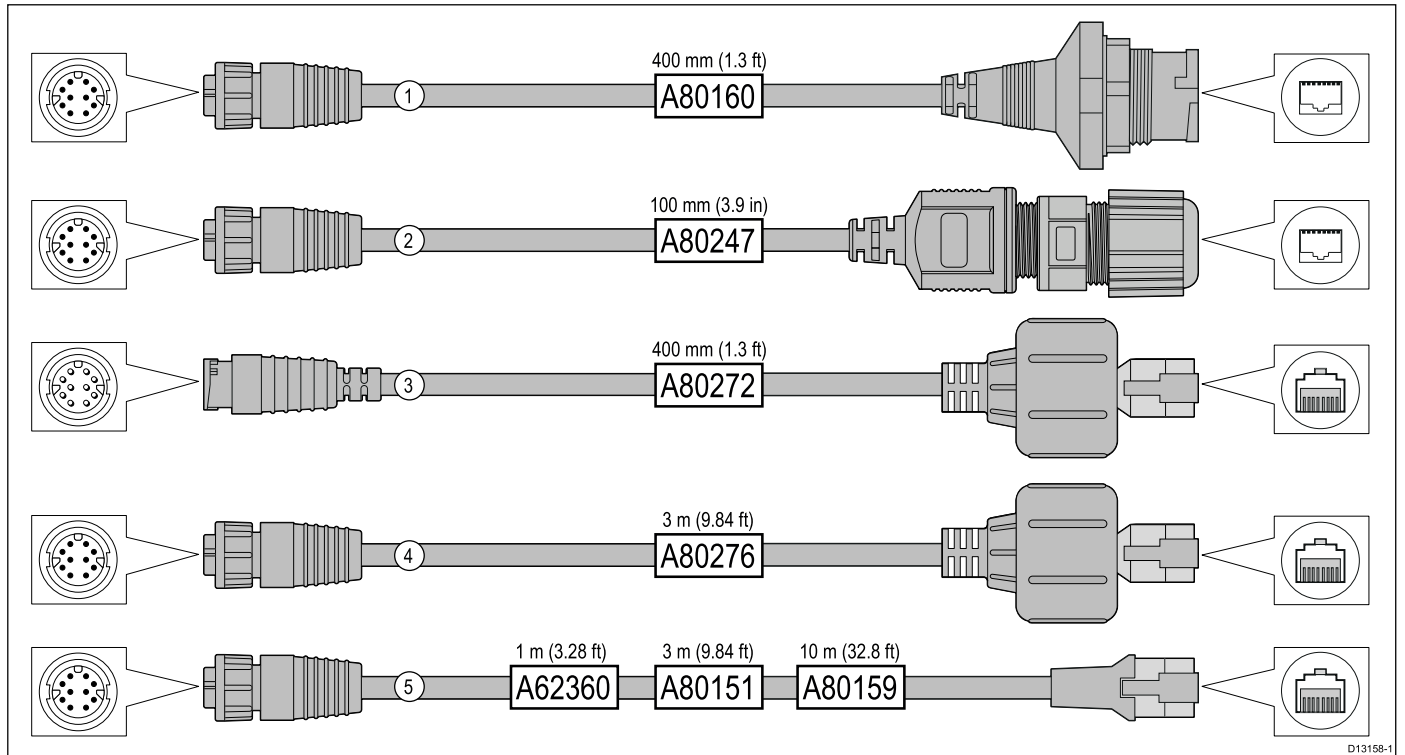

D13158-1

	Description	Typical use	Quantity
1	<p>Adapter cable with a RayNet (female) socket on one end, and a waterproof (female) socket on the other end accepting the following cables with an RJ45 SeaTalk^{hs} waterproof locking (male) plug:</p> <ul style="list-style-type: none"> • A62245 (1.5 m). • A62246 (15 m). 	<p>A typical use for this adapter cable is to connect a DSM300 sonar module to a LightHouse MFD, using all-waterproof cable connections. This adapter cable will also accept the following RJ45 SeaTalk^{hs} cables, although the RJ45 plug that connects at the equipment end (e.g. DSM300) will NOT be waterproof:</p> <ul style="list-style-type: none"> • E55049 (1.5 m). • E55050 (5 m). • E55051 (10 m). • A62135 (15 m). • E55052 (20 m). 	1
2	<p>Adapter cable with a RayNet (female) socket on one end, and a waterproof (female) RJ45 socket on the other end, along with a locking gland for a watertight fit.</p>	<p>Directly connect a Raymarine radar scanner with an RJ45 SeaTalk^{hs} (male) cable to a RayNet network switch (e.g. HS5) or LightHouse MFD.</p>	1
3	<p>Adapter cable with a RayNet (male) plug on one end, and an RJ45 SeaTalk^{hs} waterproof (male) plug on the other end.</p>	<p>Connect a legacy G-Series GPM-400, C-Series Widescreen or E-Series Widescreen MFD to a Raymarine radar scanner supplied with a RayNet power / data cable.</p>	1
4	<p>Adapter cable with a RayNet (female) socket on one end, and an RJ45 SeaTalk^{hs} waterproof (male) plug on the other end.</p>	<p>Connect a legacy G-Series GPM-400, C-Series Widescreen or E-Series Widescreen MFD to a RayNet network switch (e.g. the HS5).</p>	1
5	<p>Adapter cable with a RayNet (female) socket on one end, and an RJ45 SeaTalk^{hs} (female) socket on the other end.</p>	<p>Connect a LightHouse MFD to a legacy SR6 switch / weather receiver or a legacy 8–port SeaTalk^{hs} network switch. Another common use for the cable is in conjunction with a crossover coupler (E55060 or R32142) to connect Raymarine products with an RJ45 connection (e.g. radar scanner, thermal camera or DSM300) to a LightHouse MFD or RayNet network switch (e.g. the HS5).</p>	1

Raymarine[®]
BY  **FLIR**[®]



www.raymarine.com

CE 0168 