

Raymarine®



RAY53/63/73

Installation and operation instructions

English (en-US)
Date: 09-2018
Document number: 81381-2
© 2018 Raymarine UK Limited

Trademark and patents notice

Raymarine, Tacktick, Clear Pulse, Truzoom, SeaTalk, SeaTalk^{hs}, SeaTalk^{ng}, and Micronet, are registered or claimed trademarks of Raymarine Belgium.

FLIR, LightHouse, DownVision, SideVision, RealVision, Dragonfly, Quantum, Axiom, Instalert, Infrared Everywhere, The World's Sixth Sense and ClearCruise are registered or claimed trademarks of FLIR Systems, Inc.

All other trademarks, trade names, or company names referenced herein are used for identification only and are the property of their respective owners.

This product is protected by patents, design patents, patents pending, or design patents pending.

Fair Use Statement

You may print no more than three copies of this manual for your own use. You may not make any further copies or distribute or use the manual in any other way including without limitation exploiting the manual commercially or giving or selling copies to third parties.

Software updates



Check the Raymarine website for the latest software releases for your product.
www.raymarine.com/software

Product documentation



The latest versions of all English and translated documents are available to download in PDF format from the website: www.raymarine.com/manuals.
Please check the website to ensure you have the latest documentation.

Copyright ©2018 Raymarine UK Ltd. All rights reserved.

Contents

| | |
|--------------------------------------------------------------------------|-----------|
| Chapter 1 Important information | 13 |
| Certified Installation..... | 13 |
| FCC..... | 13 |
| Compliance Statement (Part 15.19)..... | 13 |
| FCC Interference Statement (Part 15.105 (b)) | 14 |
| Innovation, Science and Economic Development Canada (ISED)..... | 14 |
| Innovation, Sciences et Développement économique Canada (Français) | 14 |
| Water ingress | 15 |
| Disclaimer | 15 |
| Declaration of Conformity..... | 15 |
| Product disposal | 15 |
| Warranty registration..... | 15 |
| IMO and SOLAS | 16 |
| Technical accuracy..... | 16 |
| Chapter 2 Document and product information..... | 17 |
| 2.1 Product documentation..... | 18 |
| SeaTalkng® documentation..... | 18 |
| User manuals Print Shop | 18 |
| Document conventions..... | 18 |
| Document illustrations | 19 |
| 2.2 Product overview | 20 |
| 2.3 Applicable products..... | 21 |
| Required additional components..... | 21 |
| Optional additional components..... | 21 |
| Optional wireless components | 22 |
| Compatible MFDs | 22 |
| Incompatible MFDs..... | 23 |
| 2.4 Parts supplied – Ray53..... | 24 |
| 2.5 Parts supplied – Ray63 / Ray73 | 25 |
| 2.6 Licensing | 26 |
| USA licensing requirements | 26 |
| Canada licensing requirements..... | 26 |
| Europe and rest of world licensing requirements..... | 26 |
| Additional information – Ray53 | 26 |
| Additional information – Ray63 | 26 |
| Additional information – Ray73..... | 26 |
| Additional information - wireless handset..... | 27 |
| Additional information - wireless charging holster..... | 27 |
| Additional information - wireless hub | 27 |
| Additional information - wireless speaker..... | 27 |

| | |
|-----------------------------------------------------------------|----|
| 2.7 Obtain MMSI (Maritime Mobile Service Identity) number | 29 |
| 2.8 Automatic Transmitter Identification System (ATIS) | 30 |
| 2.9 Software updates | 31 |
| Checking software versions | 31 |

Chapter 3 Installation 33

| | |
|--------------------------------------------------------------|----|
| 3.1 Selecting a location..... | 34 |
| General location requirements | 34 |
| GNSS (GPS) location requirements..... | 35 |
| External GNSS (GPS) antenna location requirements..... | 36 |
| Antenna mounting and EME exposure | 36 |
| 3.2 EMC installation guidelines..... | 37 |
| Suppression ferrites..... | 37 |
| Connections to other equipment..... | 37 |
| 3.3 Wireless product location requirements | 38 |
| Wireless location requirements | 38 |
| Pre-installation site survey..... | 38 |
| 3.4 Product dimensions | 40 |
| Product dimensions — Ray53..... | 40 |
| Product dimensions — Ray63 / Ray73 | 41 |
| Product dimensions — Fistmic..... | 42 |
| Product dimensions - Wired handset (Raymic) | 43 |
| Product dimensions - speakers | 44 |
| Product dimensions - Wireless hub | 44 |
| Product dimensions - Wireless handset and holster..... | 45 |
| 3.5 Mounting | 46 |
| Tools required for installation | 46 |
| Mounting options..... | 47 |
| Bracket mounting | 47 |
| Panel mounting — Ray53..... | 48 |
| Panel mounting — Ray63 / Ray73..... | 51 |
| Fistmic mounting..... | 54 |
| Wired handset mounting using the holster..... | 55 |
| Wired and wireless speaker mounting | 56 |
| Pass-through panel kit mounting..... | 58 |
| Mounting the wireless hub | 59 |
| Mounting the charging holster for the wireless handset | 62 |

Chapter 4 Cables and connections..... 63

| | |
|------------------------------------|----|
| 4.1 General cabling guidance | 64 |
| Cable types and length..... | 64 |
| Routing cables | 64 |
| Strain relief..... | 64 |

| | |
|-----------------------------------------------------------------|----|
| Circuit isolation | 64 |
| Cable shielding | 65 |
| Connections to other equipment..... | 65 |
| Dust caps | 65 |
| Bare end wire connections | 65 |
| 4.2 Connections overview — Ray53..... | 66 |
| 4.3 Connections overview — Ray63 / Ray73..... | 67 |
| Primary and secondary station connectors | 68 |
| 4.4 Power connection | 69 |
| In-line fuse and thermal breaker ratings | 69 |
| Grounding..... | 69 |
| Power distribution..... | 70 |
| 4.5 Fistmic connection (Ray63 / Ray73 only)..... | 74 |
| 4.6 Secondary handset station (Ray63 / Ray73 only)..... | 76 |
| Wired handset extension cables..... | 76 |
| Connecting handsets and cables | 76 |
| 4.7 SeaTalkng [®] / NMEA 2000 connection | 77 |
| Connecting SeaTalkng [®] cables | 77 |
| 4.8 NMEA 0183 connection | 78 |
| 4.9 Connecting a VHF antenna..... | 79 |
| 4.10 GNSS (GPS) antenna connection..... | 80 |
| 4.11 Passive speaker connection..... | 81 |
| 4.12 Wireless hub connection | 82 |
| 4.13 Wireless handset charging holster – power connection | 83 |
| In-line fuse and thermal breaker ratings | 83 |
| 4.14 Wireless handset connections | 84 |
| 4.15 Wireless speaker – power connection..... | 85 |
| In-line fuse and thermal breaker ratings | 85 |
| 4.16 Loud hailer connection (Ray73 only) | 86 |

Chapter 5 Getting started 87

| | |
|-----------------------------------------|-----|
| 5.1 Controls and interface | 88 |
| 5.2 Handset controls | 90 |
| 5.3 Powering the unit on..... | 91 |
| Powering the handset..... | 92 |
| 5.4 Powering the unit off..... | 93 |
| 5.5 Homescreen overview | 94 |
| Status bar symbols..... | 95 |
| Main menu overview..... | 97 |
| 5.6 Shortcut list | 100 |
| Adjusting Brightness and Contrast | 100 |
| 5.7 Shared Brightness | 101 |

| | |
|---------------------------------------------------------|-----|
| Enabling Shared Brightness | 101 |
| 5.8 Initial startup..... | 103 |
| 5.9 Accessing the menu | 104 |
| 5.10 Selecting a language..... | 105 |
| 5.11 Switching on the AIS receiver | 106 |
| 5.12 Selecting a network type | 107 |
| 5.13 Entering your MMSI number..... | 108 |
| 5.14 Entering your ATIS ID | 110 |
| Enabling and disabling ATIS mode..... | 111 |
| 5.15 Changing the radio region..... | 112 |
| 5.16 Switching between high and low transmit power..... | 113 |
| 5.17 GNSS (GPS) set up..... | 114 |
| Enabling and disabling the internal GNSS (GPS) | 114 |
| Switching between internal and external antenna | 114 |
| No position data | 114 |
| Entering position manually | 114 |
| Selecting (GNSS) GPS information to display | 114 |
| Setting time format and offset | 115 |
| 5.18 Station priority (Ray63 and Ray73 only) | 116 |

Chapter 6 Wireless handset stations.....117

| | |
|-------------------------------------------------------------------|-----|
| 6.1 Wireless handsets..... | 118 |
| Wireless handset charging | 118 |
| 6.2 Connecting a wireless handset to the hub | 120 |
| Checking the Wireless hub's password..... | 121 |
| Changing your wireless hub's password | 121 |
| Changing the hub's wireless channel..... | 121 |
| Changing the Wireless hub's name | 121 |
| 6.3 Connecting the wireless speaker to the Wireless handset | 123 |
| Disconnecting a Wireless speaker..... | 123 |
| 6.4 Wireless set-up menu options | 124 |
| Wireless hub set-up menu options | 124 |
| Wireless handset not connected menu | 124 |

Chapter 7 Digital selective calling (DSC)127

| | |
|-----------------------------------------------------|-----|
| 7.1 Digital Selective Calling (DSC)..... | 128 |
| 7.2 Distress calls | 130 |
| Making a designated distress call..... | 130 |
| Making a distress call..... | 130 |
| Making a Mayday call | 131 |
| Cancelling a distress call before transmission..... | 131 |
| Cancelling a distress call after transmission | 132 |
| Receiving a distress call..... | 133 |

| | |
|-------------------------------------------------------|------------|
| Ignoring a distress call | 134 |
| Acknowledging a distress call | 134 |
| Manually relaying a distress call | 134 |
| Distress relays sent by other stations | 134 |
| 7.3 Urgency calls..... | 136 |
| Making an urgency call..... | 136 |
| Receiving an urgency call..... | 136 |
| 7.4 Safety calls..... | 137 |
| Making a safety call | 137 |
| Receiving a safety call | 137 |
| 7.5 Individual (routine) calls | 138 |
| Making an Individual call..... | 138 |
| Receiving an Individual call..... | 138 |
| 7.6 Group calls | 139 |
| Making a group call | 139 |
| Receiving a group call | 139 |
| 7.7 Position requests | 140 |
| Making a position request | 140 |
| Responding to a position request..... | 140 |
| Setting automatic response to position requests | 140 |
| 7.8 Phonebook..... | 141 |
| Adding a Phonebook entry..... | 141 |
| Editing a Phonebook entry | 141 |
| Deleting a Phonebook entry..... | 141 |
| 7.9 Call logs | 142 |
| Accessing the call logs | 142 |
| 7.10 Test calls | 143 |
| Making a Test call..... | 143 |
| Receiving a test call..... | 143 |
| 7.11 DSC set-up menu options..... | 144 |
| Chapter 8 VHF operations | 145 |
| 8.1 Watch modes..... | 146 |
| Setting Watch mode | 146 |
| 8.2 Scan Mode | 147 |
| Setting Scan mode | 147 |
| 8.3 Priority channels | 148 |
| Switching between priority channels..... | 148 |
| Setting a second priority channel | 148 |
| 8.4 Sensitivity | 149 |
| Switching sensitivity modes..... | 149 |
| 8.5 Private channels | 150 |

| | |
|--------------------------------------------------------------------------------|------------|
| Selecting a private channel set..... | 150 |
| 8.6 Automatic Transmitter Identification System (ATIS) and Marcom-C mode | 151 |
| Enabling and disabling ATIS mode..... | 151 |
| 8.7 AIS receiver | 152 |
| Switching AIS on and off..... | 152 |
| 8.8 Set-up menu options | 153 |
| Display Set-up menu..... | 154 |
| Shared Brightness menu | 154 |
| Chapter 9 Hailer, Fog horn, and Intercom | 157 |
| 9.1 Hailer Fog Intercom menu | 158 |
| 9.2 Loud hailer | 159 |
| Using the hailer..... | 159 |
| 9.3 Fog horn | 160 |
| Using the fog horn in manual mode | 160 |
| Using automatic fog horn modes..... | 160 |
| Switching off Fog Horn mode | 160 |
| 9.4 Intercom..... | 161 |
| Using the intercom | 161 |
| Responding to the intercom | 161 |
| Chapter 10 Maintenance | 163 |
| 10.1 Maintenance..... | 164 |
| Routine checks | 164 |
| Unit cleaning instructions | 164 |
| Chapter 11 Troubleshooting | 165 |
| 11.1 Troubleshooting | 166 |
| Performing a system reset..... | 166 |
| System test | 166 |
| Checking for RF interference..... | 166 |
| 11.2 Power up troubleshooting | 167 |
| 11.3 VHF Radio troubleshooting | 169 |
| 11.4 GNSS (GPS) troubleshooting | 170 |
| Chapter 12 Technical support..... | 171 |
| 12.1 Raymarine product support and servicing..... | 172 |
| 12.2 Viewing product information | 174 |
| 12.3 Learning resources | 175 |
| Chapter 13 Technical specification | 177 |
| 13.1 Technical specification — Ray53 | 178 |
| 13.2 Technical specification — Ray63 | 180 |
| 13.3 Technical specification — Ray73..... | 182 |
| 13.4 Technical specification — Wired handset (Raymic) | 184 |

| | |
|---------------------------------------------------------------------------|------------|
| 13.5 Technical specification - Wired (Passive) speaker..... | 185 |
| 13.6 Technical specification - Wireless hub..... | 186 |
| 13.7 Technical specification - Wireless handset..... | 187 |
| 13.8 Technical specification - Wireless handset charging holster | 188 |
| 13.9 Technical specification - Wireless (Active) speaker..... | 189 |
| Chapter 14 Spares and accessories..... | 191 |
| 14.1 Accessories | 192 |
| 14.2 Ray53 / Ray63 / Ray73 spares | 193 |
| 14.3 SeaTalkng [®] cables and accessories | 194 |
| Appendix A NMEA 0183 sentences | 197 |
| Appendix B NMEA 2000 PGN list..... | 198 |
| Appendix C MMSI Regulatory bodies and application submissions..... | 200 |
| Appendix D VHF Channels | 201 |
| Appendix E Phonetic alphabet | 212 |
| Appendix F Prowords | 213 |

Chapter 1: Important information

Certified Installation

Raymarine recommends certified installation by a Raymarine approved installer. A certified installation qualifies for enhanced product warranty benefits. Contact your Raymarine dealer for further details, and refer to the separate warranty document packed with your product.



Warning: Product installation and operation

- This product must be installed and operated in accordance with the instructions provided. Failure to do so could result in personal injury, damage to your vessel and/or poor product performance.
- Raymarine recommends certified installation by a Raymarine approved installer. A certified installation qualifies for enhanced product warranty benefits. Contact your Raymarine dealer for further details, and refer to the separate warranty document packed with your product.



Warning: Potential ignition source

This product is NOT approved for use in hazardous/flammable atmospheres. Do NOT install in a hazardous/flammable atmosphere (such as in an engine room or near fuel tanks).



Warning: 12 Volt dc only

This product must only be connected to a **12 volt dc** power source.



Warning: Chassis grounding

Do NOT ground this product using the chassis ground terminal.
Grounding this product to a vessel's RF ground may cause galvanic corrosion.



Warning: VHF Antenna isolation

To prevent galvanic corrosion your VHF antenna must be isolated from any vessel metalwork using a suitable, insulated (e.g. plastic) mounting bracket.



Warning: Positive ground systems

Do not connect this unit to a system which has positive grounding.



Warning: Switch off power supply

Ensure the vessel's power supply is switched OFF before starting to install this product. Do NOT connect or disconnect equipment with the power switched on, unless instructed in this document.

FCC



Warning: FCC Warning (Part 15.21)

Changes or modifications to this equipment not expressly approved in writing by Raymarine Incorporated could violate compliance with FCC rules and void the user's authority to operate the equipment.

Compliance Statement (Part 15.19)

This device complies with Part 15 of the FCC Rules. Operation is subject to the following two conditions:

1. This device may not cause harmful interference.
2. This device must accept any interference received, including interference that may cause undesired operation.

FCC Interference Statement (Part 15.105 (b))

This equipment has been tested and found to comply with the limits for a Class B digital device, pursuant to Part 15 of the FCC Rules.

These limits are designed to provide reasonable protection against harmful interference in a residential installation. This equipment generates, uses, and can radiate radio frequency energy and, if not installed and used in accordance with the instructions, may cause harmful interference to radio communications. However, there is no guarantee that interference will not occur in a particular installation. If this equipment does cause harmful interference to radio or television reception, which can be determined by turning the equipment off and on, the user is encouraged to try to correct the interference by one of the following measures:

1. Reorient or relocate the receiving antenna.
2. Increase the separation between the equipment and receiver.
3. Connect the equipment into an outlet on a circuit different from that to which the receiver is connected.
4. Consult the dealer or an experienced radio / TV technician for help.

Innovation, Science and Economic Development Canada (ISED)

This device complies with License-exempt RSS standard(s).

Operation is subject to the following two conditions:

1. This device may not cause interference; and
2. This device must accept any interference, including interference that may cause undesired operation of the device.

This Class B digital apparatus complies with Canadian ICES-003.

Innovation, Sciences et Développement économique Canada (Français)

Cet appareil est conforme aux normes d'exemption de licence RSS.

Son fonctionnement est soumis aux deux conditions suivantes:

1. cet appareil ne doit pas causer d'interférence, et
2. cet appareil doit accepter toute interférence, notamment les interférences qui peuvent affecter son fonctionnement.

Cet appareil numérique de la classe B est conforme à la norme NMB-003 du Canada.



Warning: Maximum Permissible Exposure

For optimal radio performance and minimal human exposure to Radio Frequency (RF) electromagnetic energy, you must ensure that the antenna is:

- connected to the radio before transmitting
- located where it will be away from people
- located at least 1.8 meters (5.9 feet) from the radio's main unit

Failure to observe these guidelines may expose those within the Maximum Permissible Exposure (MPE) radius to RF radiation absorption that exceeds the FCC MPE limit. It is the radio operator's responsibility to ensure that no person comes within this radius.

Caution: Perform regular radio checks

Perform regular radio checks when using your vessel, as recommended in radio training and certification schemes and radio equipment rules of use.

Caution: Ensure proper radio use

Under no circumstances should a DSC distress alert be sent from your radio for test purposes. Such action is a violation of rules of use for radio equipment, and can result in heavy fines.

Water ingress

Water ingress disclaimer

Although the waterproof rating capacity of this product meets the stated water ingress protection standard (refer to the product's *Technical Specification*), water intrusion and subsequent equipment failure may occur if the product is subjected to commercial high-pressure washing. Raymarine will not warrant products subjected to high-pressure washing.

Disclaimer

Raymarine does not warrant that this product is error-free or that it is compatible with products manufactured by any person or entity other than Raymarine.

Raymarine is not responsible for damages or injuries caused by your use or inability to use the product, by the interaction of the product with products manufactured by others, or by errors in information utilized by the product supplied by third parties.

Declaration of Conformity

FLIR Belgium BVBA declares that the radio equipment types listed below are in compliance with the Radio Equipment Directive 2014/53/EU.

| Product | Part number |
|----------------|--------------------|
| Ray53 | E70524 |
| Ray63 | E70516 |
| Ray73 | E70517 |

The original Declaration of Conformity certificate may be viewed on the relevant product page at www.raymarine.com/manuals.

Product disposal

Dispose of this product in accordance with the WEEE Directive.

The Waste Electrical and Electronic Equipment (WEEE) Directive requires the recycling of waste electrical and electronic equipment which contains materials, components and substances that may be hazardous and present a risk to human health and the environment when WEEE is not handled correctly.



■ Equipment marked with the crossed-out wheeled bin symbol indicates that the equipment should not be disposed of in unsorted household waste.

Local authorities in many regions have established collection schemes under which residents can dispose of waste electrical and electronic equipment at a recycling center or other collection point.

For more information about suitable collection points for waste electrical and electronic equipment in your region, refer to the Raymarine website: www.raymarine.com/manuals.

Warranty registration

To register your Raymarine product ownership, please visit www.raymarine.com and register online.

It is important that you register your product to receive full warranty benefits. Your unit package includes a bar code label indicating the serial number of the unit. You will need this serial number when registering your product online. You should retain the label for future reference.

IMO and SOLAS

The equipment described within this document is intended for use on leisure marine boats and workboats NOT covered by International Maritime Organization (IMO) and Safety of Life at Sea (SOLAS) Carriage Regulations.

Technical accuracy

To the best of our knowledge, the information in this document was correct at the time it was produced. However, Raymarine cannot accept liability for any inaccuracies or omissions it may contain. In addition, our policy of continuous product improvement may change specifications without notice. As a result, Raymarine cannot accept liability for any differences between the product and this document. Please check the Raymarine website (www.raymarine.com) to ensure you have the most up-to-date version(s) of the documentation for your product.

Chapter 2: Document and product information

Chapter contents

- 2.1 Product documentation on page 18
- 2.2 Product overview on page 20
- 2.3 Applicable products on page 21
- 2.4 Parts supplied – Ray53 on page 24
- 2.5 Parts supplied – Ray63 / Ray73 on page 25
- 2.6 Licensing on page 26
- 2.7 Obtain MMSI (Maritime Mobile Service Identity) number on page 29
- 2.8 Automatic Transmitter Identification System (ATIS) on page 30
- 2.9 Software updates on page 31

2.1 Product documentation

The following documentation is applicable to your product:

| Description | Part number |
|-----------------------------------------|-----------------------|
| Installation and operation instructions | 81381 (This document) |
| Ray53 mounting template | 87218 |
| Ray63 / Ray73 mounting template | 87219 |

All documents are available to download in pdf format from the Raymarine website www.raymarine.com/manuals.

SeaTalkng® documentation

| Description | Part number |
|---------------------------------------------------------------------------------------------------------------------------------------|-------------|
| SeaTalkng® reference manual Planning and connection of systems based around the SeaTalkng® network. | 81300 |
| SeaTalk — SeaTalkng® converter installation instructions Installation and connection of the SeaTalk — SeaTalkng® converter. | 87121 |

User manuals Print Shop

Raymarine provides a Print Shop service, enabling you to purchase a high-quality, professionally-printed manual for your Raymarine product.

Printed manuals are ideal for keeping onboard your vessel, as a useful source of reference whenever you need assistance with your Raymarine product.

Visit <http://www.raymarine.co.uk/view/?id=5175> to order a printed manual, delivered directly to your door.

For further information about the Print Shop, please visit the Print Shop FAQ pages: <http://www.raymarine.co.uk/view/?id=5751>.

Note:

- Accepted methods of payment for printed manuals are credit cards and PayPal.
- Printed manuals can be shipped worldwide.
- Further manuals will be added to the Print Shop over the coming months for both new and legacy products.
- Raymarine user manuals are also available to download free-of-charge from the Raymarine website, in the popular PDF format. These PDF files can be viewed on a PC / laptop, tablet, smartphone, or on the latest generation of Raymarine multifunction displays.

Document conventions

The following conventions are used throughout this document.

Procedures for performing specific tasks using the product's user interface.

The term "Select" is used to refer to the action of:

- Touchscreen control — using your finger to select a menu option or item on the screen.
- Physical buttons — Highlighting an item using the navigational controls and confirming the selection by pressing the **OK** button.

Examples:

- Select **Ok** to confirm your selection.
- Select **Set-up**

Procedures for navigating menu hierarchies.

Menu hierarchies are used in this document to provide a quick summary on how to access a particular function or menu option.

Examples:

- The internal sonar module is turned off from the Fishfinder application menu: **Menu > Set-up > Sounder Set-up > Internal Sounder**.
- The internal GPS can be switched off from the Set-up menu: **Menu > Set-up > GPS Set-up > Internal GPS**.

Document illustrations

Your product and if applicable, its user interface may differ slightly from that shown in the illustrations in this document, depending on product variant and date of manufacture.

All images are provided for illustration purposes only.

2.2 Product overview

The Ray53, Ray63 and Ray73 are 12 V dc, Class D Digital Selective Calling (DSC) VHF radios. DSC enables you to make a selective call to a specific radio, and to transmit and receive position information to and from the selected radio. DSC also allows transmission of a distress alert to all radios within range at the touch of a button. Once a DSC request is sent and acknowledged, voice communication is carried out on the channel chosen by the caller. The radio can transmit and receive on all available US, Canadian, International and Private marine VHF channels.

Your product includes the following features:

- Built-in GNSS (GPS) receiver with internal antenna and an external antenna connection.
- Built-in GNSS (GPS) receiver can be used as a source of GNSS position data for other devices in your network.
- Networkable: Connect to NMEA 2000 / SeaTalkng[®] or NMEA 0183.
- Expandible:
 - Add an optional passive speaker (all variants).
 - Add a second fully functional wired handset station (Ray63 / Ray73 only), or
 - Connect the optional Wireless hub to the second station connector, allowing up to 2 fully functioning wireless handset stations.
 - Add an optional Loud Hailer the Ray73 can be used as a fog horn or loud public address (PA) system.
- Built-in AIS receiver (Ray73 only).

2.3 Applicable products

This document is applicable to the following products:

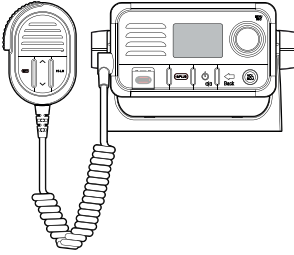
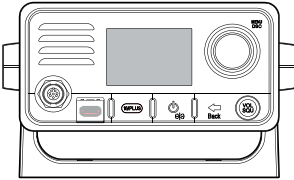
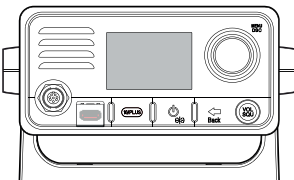
| | Name | Part number | Features |
|------------------------------------------------------------------------------------|--------|-------------|------------------------------------------------------------------------------------------------------------------------------------------------------------------------------------------------|
|  | E70524 | Ray53 | <ul style="list-style-type: none"> • SeaTalkng® / NMEA 2000 • NMEA 0183 • Built-in GNSS (GPS and GLONASS) receiver • Passive speaker connection |
|  | E70516 | Ray63 | Same as Ray53 with additional: <ul style="list-style-type: none"> • Up to 2 Wired handset stations, or • 1 Wired handset station and up to 2 Wireless handset stations |
|  | E70517 | Ray73 | Same as Ray63 with additional: <ul style="list-style-type: none"> • Built-in AIS receiver • Loud hailer connection |

Required additional components

Your product requires a VHF antenna.

| Part number | Description |
|-------------|------------------------------------------|
| N/A | 3 rd Party 50 ohm VHF antenna |

Optional additional components

GNSS / GPS antenna

You can improve the performance of your radio's built-in GNSS (GPS) receiver using an external antenna.

| Part number | Description |
|-------------|----------------------------|
| A80288 | Passive GNSS (GPS) antenna |

Ray53

| Part number | Description |
|-------------|-------------------------|
| A80542 | Wired speaker (passive) |

Ray63 / Ray73

| Part number | Description |
|-------------|-------------------------|
| A80542 | Wired speaker (passive) |
| A80289 | Wired handset (Raymic) |

Ray73

| Part number | Description |
|-------------|-------------|
| M95435 | Loud Hailer |

Extension cables

The following extension cables are available:

| Part number | Description |
|-------------|-----------------------------------------------------------------|
| A80291 | Wired handset extension cable 5 m (16.4 ft) |
| A80292 | Wired handset extension cable 10 m (32.8 ft) |
| A80290 | Wired handset extension cable 15 m (49.2 ft) |
| A80297 | Wired handset adaptor cable with male RCA audio (400 mm 1.3 ft) |

Optional wireless components

Your radio supports connection of wireless handsets and speakers via a wireless hub, enabling creation of additional fully functional, wireless handset stations.

The following wireless components are available:

| Part number | Component | Description |
|-------------|--------------------------------------|---------------------------------------------------------------------------|
| A80540 | Wireless hub | Allows connection of up to 2 Wireless handsets. |
| R70739 | Wireless hub adaptor | Allows Wireless hub connection to Ray63 / Ray73 radios. |
| A80544 | Wireless handset (including holster) | Wireless handset with inductive charging and wireless speaker connection. |
| A80543 | Wireless speaker (Active) | Connects to the Wireless handset. |

Compatible MFDs

Your radio can be integrated with compatible MFDs, enabling DSC distress message information and position data on your MFD screen.

Compatible LightHouse™ 3 MFDs

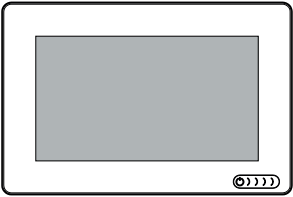
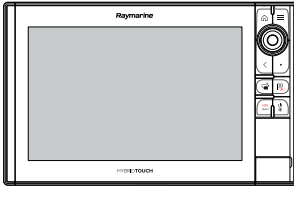
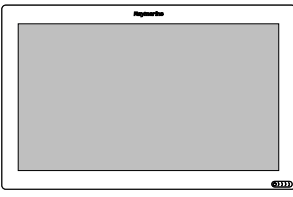
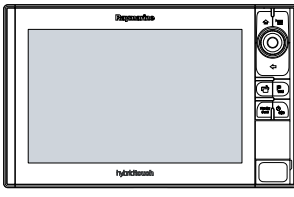
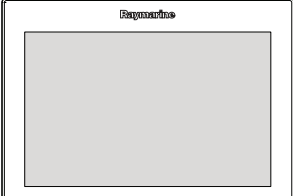
| | | | |
|-------------------------------------------------------------------------------------|-----------|--------------------------------------------------------------------------------------|------------|
|  | Axiom™ |  | Axiom™ Pro |
|  | Axiom™ XL |  | eS Series |
|  | gS Series | | |

Compatible LightHouse™ 2 MFDs

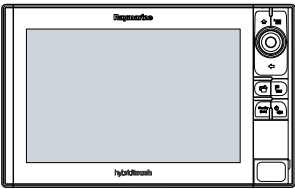
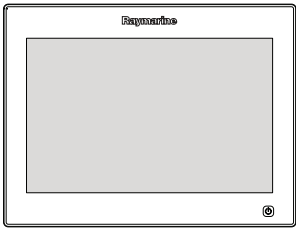
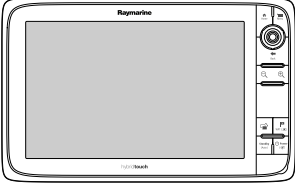
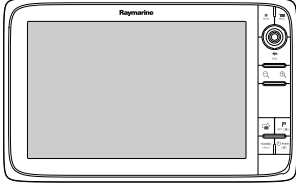
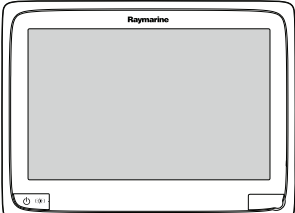
| | | | |
|-----------------------------------------------------------------------------------|-----------|------------------------------------------------------------------------------------|-----------|
|  | eS Series |  | gS Series |
|  | e Series |  | c Series |
|  | a Series | | |

Compatible Legacy MFDs

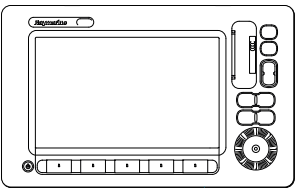
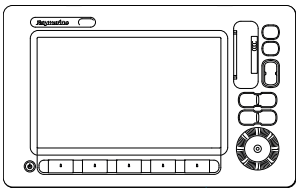
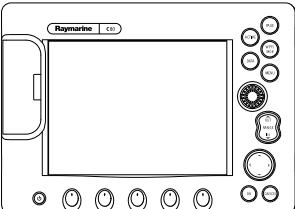
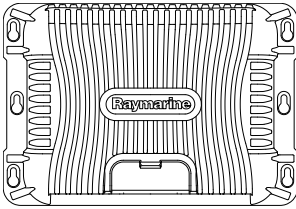
| | | | |
|-------------------------------------------------------------------------------------|---------------------|--------------------------------------------------------------------------------------|---------------------|
|  | E-Series Widescreen |  | C-Series Widescreen |
|  | E-Series Classic |  | G-Series |

Incompatible MFDs

This product is NOT compatible with the following legacy Raymarine multifunction displays.

Legacy MFDs

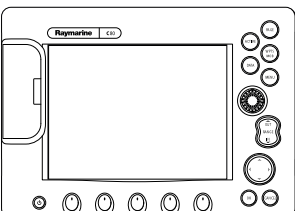
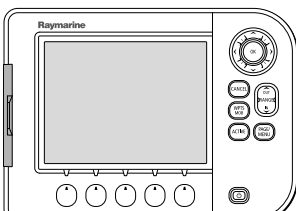
| | | | |
|-------------------------------------------------------------------------------------|------------------|--------------------------------------------------------------------------------------|------------------|
|  | C-Series Classic |  | A-Series Classic |
|-------------------------------------------------------------------------------------|------------------|--------------------------------------------------------------------------------------|------------------|

2.4 Parts supplied – Ray53

The parts listed below are supplied with the Ray53.

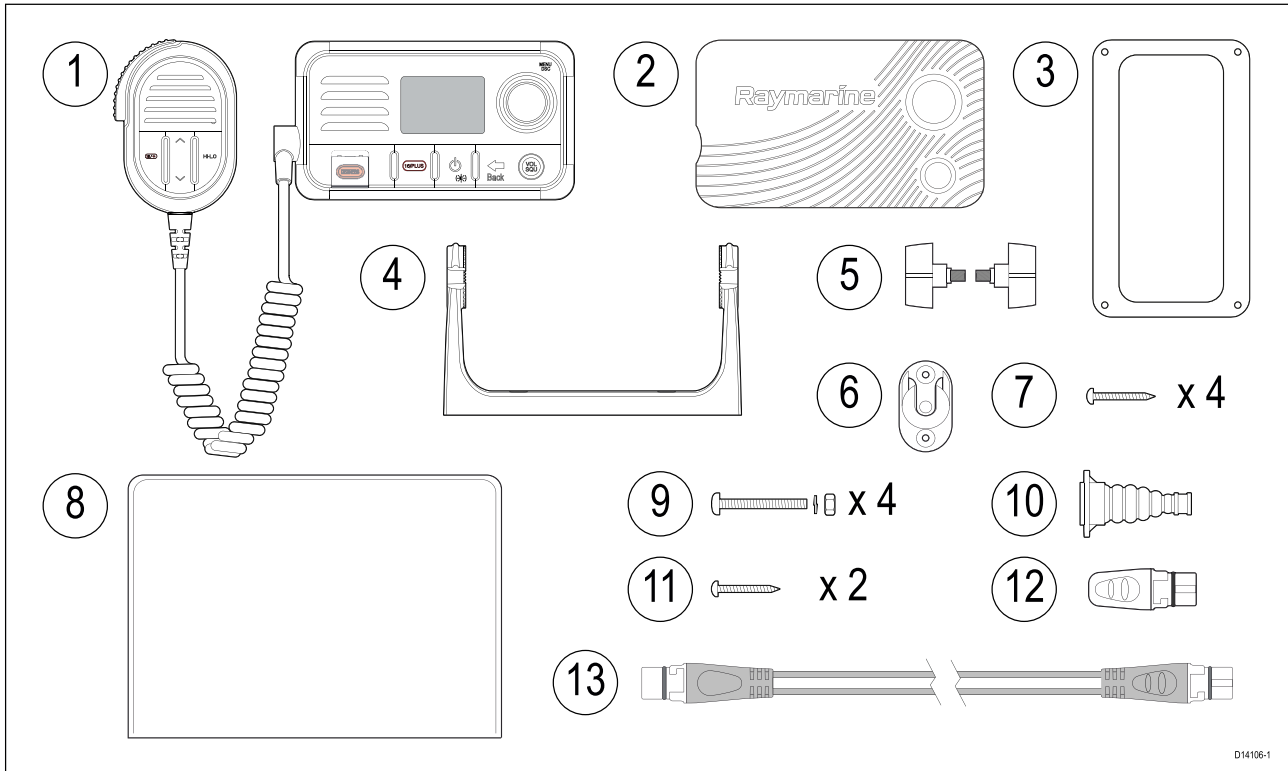

D14106-1

| Item | Description |
|------|---------------------------------------------------------------------------|
| 1 | VHF Radio |
| 2 | Sun cover |
| 3 | Panel mount gasket |
| 4 | Mounting bracket (Trunnion) |
| 5 | Mounting bracket knobs |
| 6 | Fismic hook plate |
| 7 | 4 x M4x25 screws (For Bracket (Trunnion) mounting) |
| 8 | Documentation |
| 9 | 4 x M4 nuts, spring washers and M4x25 machine screws (For Panel mounting) |
| 10 | Protective antenna boot |
| 11 | 2 x M4x12 screws (For Fismic hook plate mounting). |
| 12 | SeaTalkng® blanking plug |
| 13 | SeaTalkng® 400 mm (15.7 in.) spur cable |

2.5 Parts supplied – Ray63 / Ray73

The parts listed below are supplied with the Ray63 and Ray73.

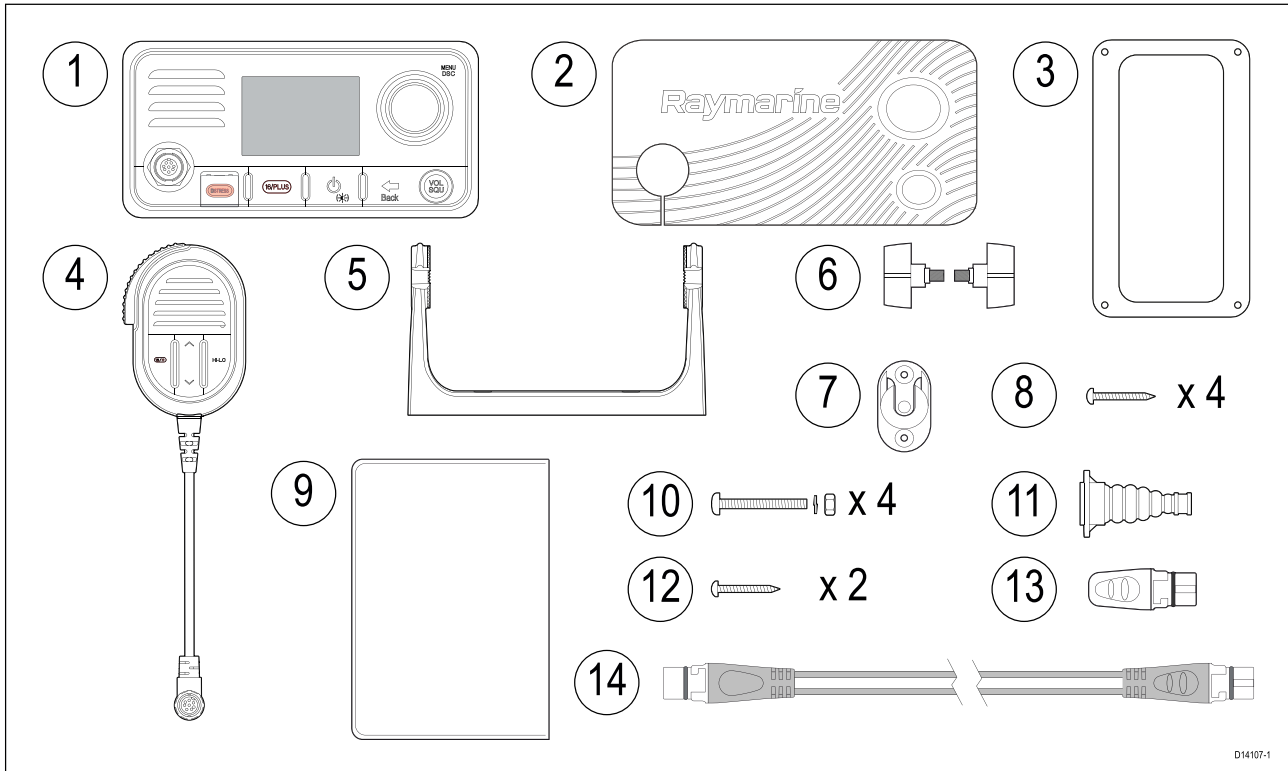

| Item | Description |
|------|---------------------------------------------------------------------------|
| 1 | VHF Radio |
| 2 | Sun cover |
| 3 | Panel mount gasket |
| 4 | Fistmic |
| 5 | Mounting bracket (Trunnion) |
| 6 | Mounting bracket knobs |
| 7 | Fistmic hook plate |
| 8 | 4 x M4x25 screws (For Bracket (Trunnion) mounting) |
| 9 | Documentation |
| 10 | 4 x M4 nuts, spring washers and M4x25 machine screws (For Panel mounting) |
| 11 | Protective antenna boot |
| 12 | 2 x M4x12 screws (For Fistmic hook plate mounting). |
| 13 | SeaTalkng® blanking plug |
| 14 | SeaTalkng® 400 mm (15.7 in.) spur cable |

2.6 Licensing

Prior to using this product please check your national requirements for both operator and equipment licensing.

USA licensing requirements

FCC station license requirement

An FCC Ship Radio Station License and Call Sign are not required for most recreational vessels travelling in US waters. However, you must obtain a license if your vessel travels to foreign ports.

Ships that use MF/HF single side-band radio, satellite communications, or telegraphy must be licensed by the FCC. You can obtain a Station License by filing FCC Form 605.

Canada licensing requirements

You do not need a license to operate this product within the sovereign waters of Canada or the United States of America (USA).

You will need a license to operate this radio outside of Canada or the USA. To obtain licensing information, visit the Innovation, Science and Economic Development Canada (ISED) (previously known as Industry Canada) website: <https://www.tc.gc.ca/eng/marinesafety/oep-navigation-radiocomms-faqs-1489.htm>.

Europe and rest of world licensing requirements

Regulations in some areas require that an Operator's license is obtained before operating a VHF radio. It is your responsibility to determine whether a license is required in your area before operating this equipment.

Additional information – Ray53

The following additional information is required for completing a license application in Canada and the US.

| | |
|-------------------|---------------------------------|
| ISED ID | 4069B-RAY50D |
| FCC ID | PJ5-RAY50 |
| FCC Type accepted | Parts 2, 15 and 80 |
| Output power | 1 watt (low) and 25 watt (high) |
| Modulation | FM |
| Frequency range | 155.500 MHz to 163.275 MHz |

Additional information – Ray63

The following additional information is required for completing a license application in Canada and the US.

| | |
|-------------------|---------------------------------|
| ISED ID | 4069B-RAY60D |
| FCC ID | PJ5-RAY60 |
| FCC Type accepted | Parts 2, 15 and 80 |
| Output power | 1 watt (low) and 25 watt (high) |
| Modulation | FM |
| Frequency range | 155.500 MHz to 163.275 MHz |

Additional information – Ray73

The following additional information is required for completing a license application in Canada and the US.

| | |
|---------|--------------|
| ISED ID | 4069B-RAY70D |
| FCC ID | PJ5-RAY70 |

| | |
|-------------------|---------------------------------|
| FCC Type accepted | Parts 2, 15 and 80 |
| Output power | 1 watt (low) and 25 watt (high) |
| Modulation | FM |
| Frequency range | 155.500 MHz to 163.275 MHz |

Additional information - wireless handset

| | |
|-------------------|------------------------------------------------|
| ISED ID: | 4069B–RAY90W |
| FCC ID: | PJ5–RAY90W |
| FCC type accepted | Parts, 2, 15 and 80 |
| Output power | 1. 19 dBm 2. 4dBm |
| Modulation | 1. MIMO-OFDM/DSSS/CCK 2. GFSK |
| Frequency | 1. 2412MHz to 2472MHz 2. 2412MHz to 2472MHz |

Note:
ISED previously IC (Industry Canada)

Additional information - wireless charging holster

| | |
|-------------------|---------------------|
| ISED ID: | 4069B–RAYCGR |
| FCC ID: | PJ5–RAYCGR |
| FCC type accepted | Parts, 2, 15 and 80 |
| Output power | 5 watt |
| Modulation | QI |
| Frequency | 110KHz to 205KHz |

Note:
ISED previously IC (Industry Canada)

Additional information - wireless hub

| | |
|-------------------|---------------------|
| ISED ID: | 4069B–RAYHUB |
| FCC ID: | PJ5–RAYHUB |
| FCC type accepted | Parts, 2, 15 and 80 |
| Output power | 19 dbm |
| Modulation | MIMO-OFDM/DSSS/CCK |
| Frequency | 2412-2472MHz |

Note:
ISED previously IC (Industry Canada)

Additional information - wireless speaker

| | |
|-------------------|---------------------|
| ISED ID: | 4069B–RAYSPK |
| FCC ID: | PJ5–RAYSPK |
| FCC type accepted | Parts, 2, 15 and 80 |

| | |
|--------------|--------------------|
| Output power | 4 dbm |
| Modulation | GFSK |
| Frequency | 2412MHz to 2472MHz |

Note:
ISED previously IC (Industry Canada)

2.7 Obtain MMSI (Maritime Mobile Service Identity) number

Before commencing installation ensure you have obtained a MMSI number for your vessel.

A MMSI is a 9 digit number which is sent over a radio frequency channel in order to identify the originating vessel/station. If your vessel already has a MMSI number (used for a VHF DSC radio) then the same MMSI number must be used to program your product.

Note:

If a MMSI number is not entered, the DSC functionality of your radio will be disabled.

In the United States of America, the MMSI and Static Data must be entered only by a Raymarine® dealer or other appropriately qualified installer of marine communications equipment on board vessels.

The user is NOT authorized to do this.

In some areas, a radio operator licence is required before a MMSI number will be issued. You can request a MMSI number from same agency that issues radio or Ship Radio licences in your area.

In Europe and other parts of the world outside of the United States of America, the MMSI and Static data can be set up by the user.

For further details, refer to the relevant Telecommunications Regulatory Body for your area.

Refer to [Appendix C MMSI Regulatory bodies and application submissions](#)

for a list of contacts for obtaining MMSI numbers for some areas.



Warning: MMSI entry

You can only enter a MMSI number once, if you enter the number incorrectly or need to change your MMSI number, the unit will require re-programming by an authorized Raymarine dealer.

2.8 Automatic Transmitter Identification System (ATIS)

Your product includes ATIS functionality for use on the inland waterways of contracting governments of the *“Regional Arrangement on the Radiocommunication Service for Inland Waterways”* — also known as *“RAINWAT”*.

ATIS adds data at the end of radio transmissions that identifies your station. ATIS operation can be turned on or off as needed via the radio’s menu.

An ATIS ID can be obtained from the same agency that issues radio operator licenses in your area.

Your ATIS ID should be programmed into your product using the instructions provided.

Note:

Contracting RAINWAT countries include: Austria, Belgium, Bulgaria, Croatia, the Czech Republic, France, Germany, Hungary, Luxembourg, Moldova, Montenegro, the Netherlands, Poland, Romania, Serbia, the Slovak Republic and Switzerland.

Note:

When ATIS is enabled, certain programming steps have been implemented to protect the integrity of the RAINWAT agreement, including the blocking of DSC functions when ATIS is enabled.

2.9 Software updates

Raymarine periodically releases software updates for its products. These updates provide new features, current feature enhancements and bug fixes which improves product performance and usability.

Check the Raymarine website: www.raymarine.com/software regularly to ensure you have the latest software for your products.

The software update process requires a compatible MFD, powered by LightHouse™ 2 release 13.37 or above, or LightHouse™ 3 version LH3.2 or above.

- Please refer to the operation instructions for your MFD / operating system version for details on how to perform the software update, alternatively refer to the instructions provided on the software download area for your product on the Raymarine website: www.raymarine.com/software.
- The MFD used to perform the software update must be the designated Data master and be connected / networked to the product being updated.
- If you are in any doubt as to the correct procedure for updating your product software, please refer to your local authorized dealer or Raymarine technical support for assistance.

Caution: Installing software updates

The software update process is carried out at your own risk. Before initiating the update process ensure you have backed up any important files.

Ensure that the unit has a reliable power supply and that the update process is not interrupted.

Damage caused by incomplete updates are not covered by Raymarine warranty.

By downloading the software update package, you agree to these terms.

Checking software versions

You can check the software version of your radio and connected components.

From the Homescreen:

1. Select **Menu > Set-up > Maintenance > About this unit.**
2. Scroll down.
Software versions of connected components are displayed.

Chapter 3: Installation

Chapter contents

- 3.1 Selecting a location on page 34
- 3.2 EMC installation guidelines on page 37
- 3.3 Wireless product location requirements on page 38
- 3.4 Product dimensions on page 40
- 3.5 Mounting on page 46

3.1 Selecting a location



Warning: Potential ignition source

This product is NOT approved for use in hazardous/flammable atmospheres. Do NOT install in a hazardous/flammable atmosphere (such as in an engine room or near fuel tanks).

General location requirements

When selecting a location for the unit it is important to consider a number of factors.

Ventilation requirements

To provide adequate airflow:

- Ensure that equipment is mounted in a compartment of suitable size.
- Ensure that ventilation holes are not obstructed.
- Ensure adequate separation of equipment.

Water ingress

Base station — Although the Base station is waterproof to IPx6 and IPx7, it is recommended that the Base station is mounted below decks, in an area protected from prolonged and direct exposure to rain and salt spray.

Wired handset — The Handset has been designed to be mounted above or below decks and is rated to IPx6 and IPx7.

Wired (Passive) speaker — The speakers has been designed to be mounted above or below decks and are rated to IPx6 and IPx7.

Mounting surface requirements

When selecting a mounting surface ensure:

- the product will be adequately supported on a secure, flat surface. Do NOT mount units or cut holes in places which may damage the structure of the vessel.
- sufficient space is available around the product.
- there is nothing behind the mounting surface that may be damaged when drilling.

Cable routing requirements

Ensure you have identified the route that all required cables will take and that sufficient space is available to allow connection of cables:

- Unless otherwise stated, a minimum cable bend radius of 100 mm (3.94 in) is required.
- Where necessary, cable supports should be used to prevent stress on connectors.

Electrical interference

Select a location that is far enough away from devices that may cause interference, such as motors, generators and radio transmitters/receivers.

Power supply

Select a location that is as close as possible to the vessel's DC power supply. This will help to keep cable runs to a minimum.

RF interference

Certain third-party external electrical equipment can cause Radio Frequency (RF) interference with GNSS (GPS), AIS or VHF devices, if the external equipment is not adequately insulated and emits excessive levels of electromagnetic interference (EMI).

Some common examples of such external equipment include LED lighting (e.g.: navigation lights, searchlights and floodlights, interior and exterior lights) and terrestrial TV tuners.

To minimize interference from such equipment:

- Keep it as far away from GNSS (GPS), AIS or VHF products and their antennas as possible.
- Ensure that any power cables for external equipment are not entangled with the power or data cables for these devices.

- Consider fitting one or more high frequency suppression ferrites to the EMI-emitting device. The ferrite(s) should be rated to be effective in the range 100 MHz to 2.5 GHz, and should be fitted to the power cable and any other cables exiting the EMI-emitting device, as close as possible to the position where the cable exits the device.

Compass safe distance

When choosing a suitable location for your product you should aim to maintain the maximum possible distance between the product and any installed compass. This distance should be at least 1 m (3 ft) in all directions. For smaller vessels it may not be possible to achieve this distance. In this situation ensure that the compass is not affected by the product when it is powered on.

GNSS (GPS) location requirements



In addition to general guidelines concerning the location of marine electronics, there are a number of environmental factors to consider when installing equipment with an internal GNSS receiver.

Mounting location

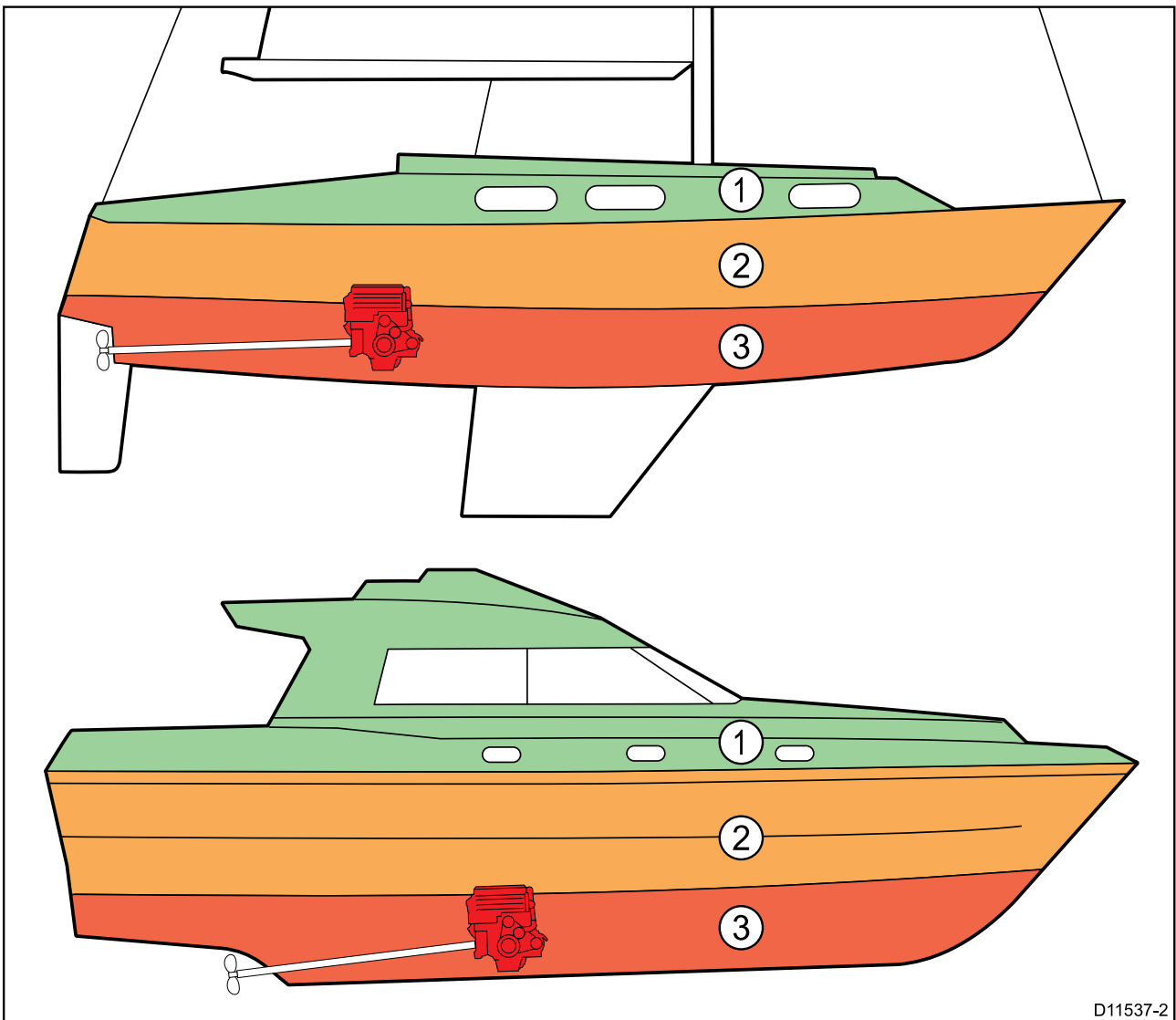
- Above Decks (e.g. open air) mounting: Provides optimal performance. (For equipment with appropriate waterproof rating.)
- Below Decks (e.g. enclosed space) mounting: Performance may be less effective and may require an external antenna or receiver mounted above decks.



D11537-2

| | | |
|---|-------------------------------------------------------------------------------------|-----------------------------------------------------------|
| 1 |  | This location provides optimal performance (above decks). |
| 2 |  | In this location, performance may be less effective. |
| 3 |  | This location is NOT recommended. |

Vessel construction

The construction of your vessel can have an impact on performance. For example, the proximity of heavy structures such as a structural bulkhead, or the interior of larger vessels may result in a reduced signal. The construction materials can also have an impact. In particular, steel, aluminium or carbon surfaces can impact performance. Before locating equipment with an internal antenna below decks, or on a steel, aluminium or carbon construction vessel or surface, seek professional assistance.

Prevailing conditions

The weather and location of the vessel can affect performance. Typically calm clear conditions provide a more accurate position fix. Vessels at extreme northerly or southerly latitudes may also receive a weaker signal. An antenna mounted below decks will be more susceptible to performance issues related to the prevailing conditions.

External GNSS (GPS) antenna location requirements

Your product includes a built-in GNSS (GPS) receiver and antenna, your product can also be connected to an GNSS (GPS) external antenna such as the GA150 which can be used instead.

When using an external antenna, ensure you follow the location requirements specified in your external antenna's installation instructions.

Note:

When using an external antenna you must select the internal antenna in order for it to be used instead of the internal antenna. See the [Switching between internal and external antenna](#) procedure.

Antenna mounting and EME exposure

Ensure that your VHF antenna is connected to the radio before transmission.

Raymarine® declares a Maximum Permissible Exposure (MPE) radius of 1.8 meters (5.9 ft.) for this system, assuming 25 watts output to an omnidirectional antenna of 3dBi gain or less.

For watercraft with suitable structures, the antenna base must be at least 3.8 meters (12.5 ft) above the main deck to meet the MPE for persons up to 2 metres (6.6 ft) tall. For watercraft without such structures, the antenna must be mounted so that its base is a minimum of 1.8 meters (5.9 ft.) vertically from heads of all persons.

The antenna must be isolated from the vessel's metalwork using an insulated (e.g. plastic) mounting bracket.

3.2 EMC installation guidelines

Raymarine® equipment and accessories conform to the appropriate Electromagnetic Compatibility (EMC) regulations, to minimize electromagnetic interference between equipment and minimize the effect such interference could have on the performance of your system

Correct installation is required to ensure that EMC performance is not compromised.

Note:

In areas of extreme EMC interference, some slight interference may be noticed. Where this occurs the product and the source of the interference should be separated by a greater distance.

For **optimum** EMC performance we recommend that wherever possible:

- Raymarine® equipment and cables connected to it are:
 - At least 1 m (3 ft) from any equipment transmitting or cables carrying radio signals e.g. VHF radios, cables and antennas. In the case of SSB radios, the distance should be increased to 2 m (7 ft).
 - More than 2 m (7 ft) from the path of a Radar beam. A Radar beam can normally be assumed to spread 20 degrees above and below the radiating element.
- The product is supplied power from a separate battery from that used for engine start. This is important to prevent erratic behavior and data loss which can occur if the engine start does not have a separate battery.
- Only Raymarine® specified cables are used.
- Cables are not cut or extended, unless doing so is detailed in the installation instructions.

Note:

Where constraints on the installation prevent any of the above recommendations, always ensure the maximum possible separation between different items of electrical equipment, to provide the best conditions for EMC performance throughout the installation.

Suppression ferrites

- Raymarine cables may be pre-fitted or supplied with suppression ferrites. These are important for correct EMC performance. If ferrites are supplied separately to the cables (i.e. not pre-fitted), you must fit the supplied ferrites, using the supplied instructions.
- If a ferrite has to be removed for any purpose (e.g. installation or maintenance), it must be replaced in the original position before the product is used.
- Use only ferrites of the correct type, supplied by Raymarine or its authorized dealers.
- Where an installation requires multiple ferrites to be added to a cable, additional cable clips should be used to prevent stress on the connectors due to the extra weight of the cable.

Connections to other equipment

Requirement for ferrites on non-Raymarine cables.

If your product is to be connected to other equipment using a cable not supplied by Raymarine, a suppression ferrite **MUST** always be attached to the end of the cable nearest to the Raymarine product.

3.3 Wireless product location requirements

The optional wireless hub, handset and active speakers require further considerations when selecting a mounting location

Wireless location requirements

A number of factors can influence wireless performance, it is important to ensure you test the connection performance, at the desired location before installing wireless enabled products.

Distance

The distance between wireless products should always be kept to a minimum. Do not exceed the maximum stated range of your wireless product (Maximum range will vary for each device).

Wireless performance degrades over distance, so products farther away will receive less network bandwidth. Products installed close to their maximum wireless range may experience slow connection speeds, signal drop outs or not being able to connect at all.

Line of sight

For best results the wireless product should have a clear, direct line of sight to the product it will be connected to. Any physical obstructions can degrade or even block the wireless signal.

The construction of your vessel can also have an impact on wireless performance. For example, metal structural bulkheads and roofing will reduce and in certain situations, block the wireless signal.

If the wireless signal passes through a bulkhead containing power cables this can also degrade wireless performance.

Reflective surfaces such as metal surfaces, some types of glass and even mirrors can drastically effect performance or even block the wireless signal.

Interference and other equipment

Wireless products should be installed at least 1m (3 ft) away from:

- Other wireless enabled products.
- Transmitting products that send wireless signals in the same frequency range.
- Other electrical, electronic or electromagnetic equipment that may generate interference.

Interference from other peoples wireless devices can also cause interference with your products. You can use a third party wireless analyzer tool / smartphone app to assess the best wireless channel (channel not in use or used by least amount of devices) for you to use.

Pre-installation site survey

Before installing a wireless device, a site survey should be performed to ensure the wireless signal strength at the desired installation location is sufficient to maintain a reliable connection.

You can perform a site survey using your smart phone or tablet and a wireless signal analyzer app such as “Wi-Fi Analyzer” by Farproc or a similar.

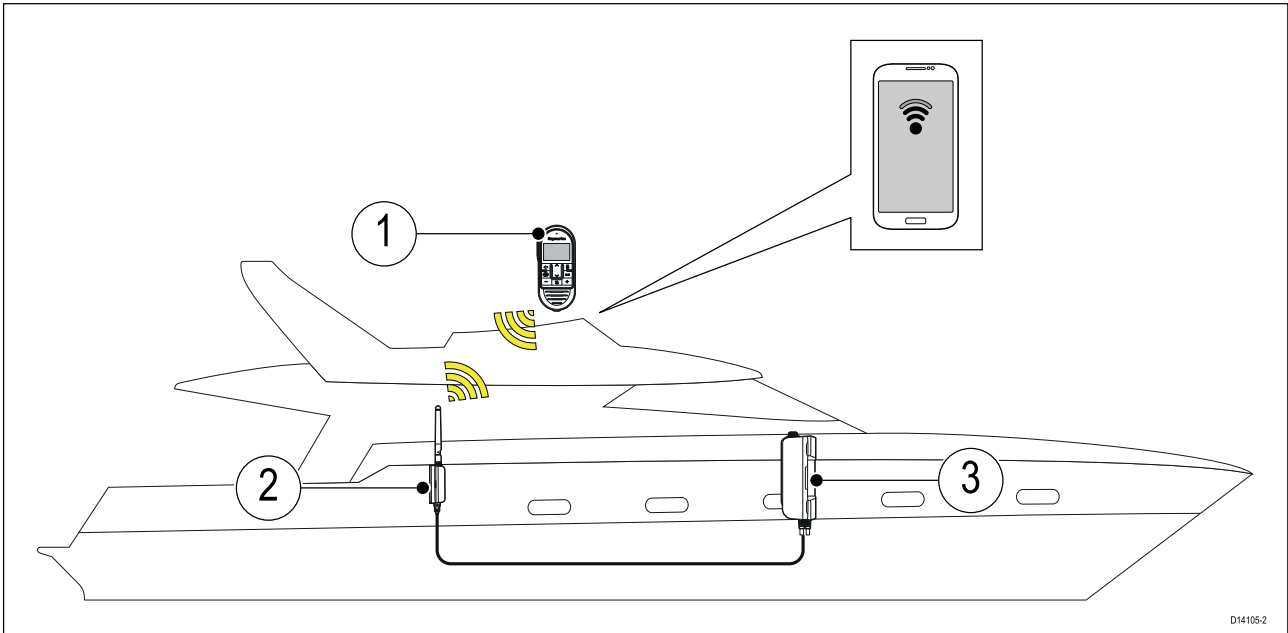

| | |
|---|------------------|
| 1 | Wireless handset |
| 2 | Wireless hub |
| 3 | VHF Radio |

1. Install the wireless analyzer app on your smart device.
2. Connect the wireless hub to your VHF Radio.
3. Move the hub to its desired location.

The hub should be located as close to the desired location of the wireless handset as possible, this can be achieved using the fitted 5 metre cable and if required a wireless hub antenna extension, which allows a farther 5 metres.

4. Power on your VHF Radio.
5. Make a note of your wireless hub's name (SSID).

*The wireless hub's name can be found using a wired handset: **Menu > Set-up > Wireless set-up > Wireless hub set-up > Hub name**. (By default the hub name will be RM followed by the full part number and serial number of the VHF Radio it is connected to e.g.: RM E70517 107828).*

6. Go to the location you have chosen for your wireless handset.
7. Open the wireless analyzer app on your smart device and scan available networks.
8. Establish the signal strength of your hub's wireless network at the chosen location.

For reliable wireless performance the signal strength should be better than -75dBm , the closer the signal is to zero the better the wireless performance will be (e.g. -40dBm is better than -75dBm).

9. If the wireless channel your hub is using is congested with wireless signals then change your hub's wireless channel (**Menu > Set-up > Wireless set-up > Wireless hub set-up > Hub name** select a different wireless channel

Try channels 1, 6 and 11 first as these are usually the preferred wireless channels. Otherwise try the channel that has the least congestion.

10. If you have a very weak or intermittent signal then you will need to investigate further, please refer to the wireless location requirements to help establish what may be causing the problem.
11. Repeat steps 6 to 10 with each wireless handset you wish to install.

3.4 Product dimensions

Product dimensions — Ray53

Panel mount dimensions

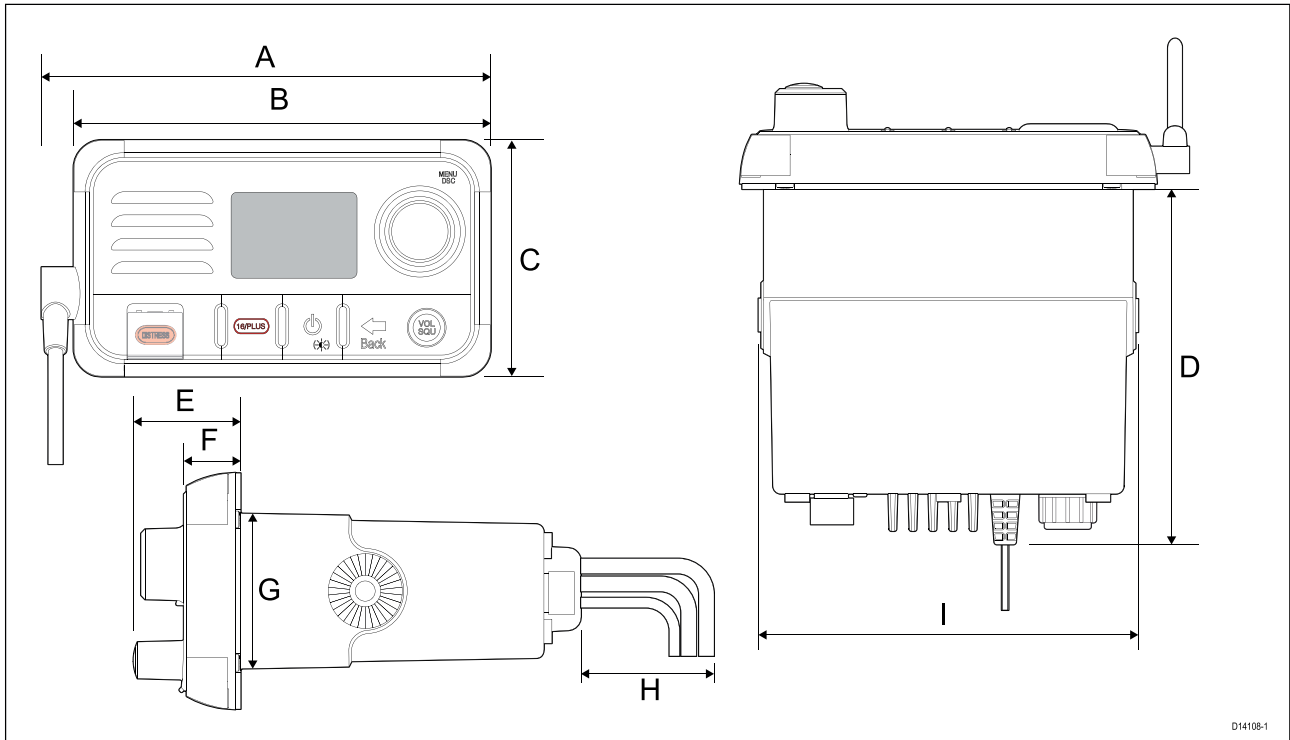

| | |
|---|-------------------|
| A | 168 mm (6.6 in) |
| B | 156 mm (6.1 in) |
| C | 88.5 mm (3.5 in) |
| D | 134 mm (5.3 in) |
| E | 39.75 mm (1.6 in) |
| F | 21.5 mm 0.85 in) |
| G | 59 mm (2.3 in) |
| H | 25 mm 1.0 in) |
| I | 143.6 mm (5.7 in) |

Bracket mount dimensions

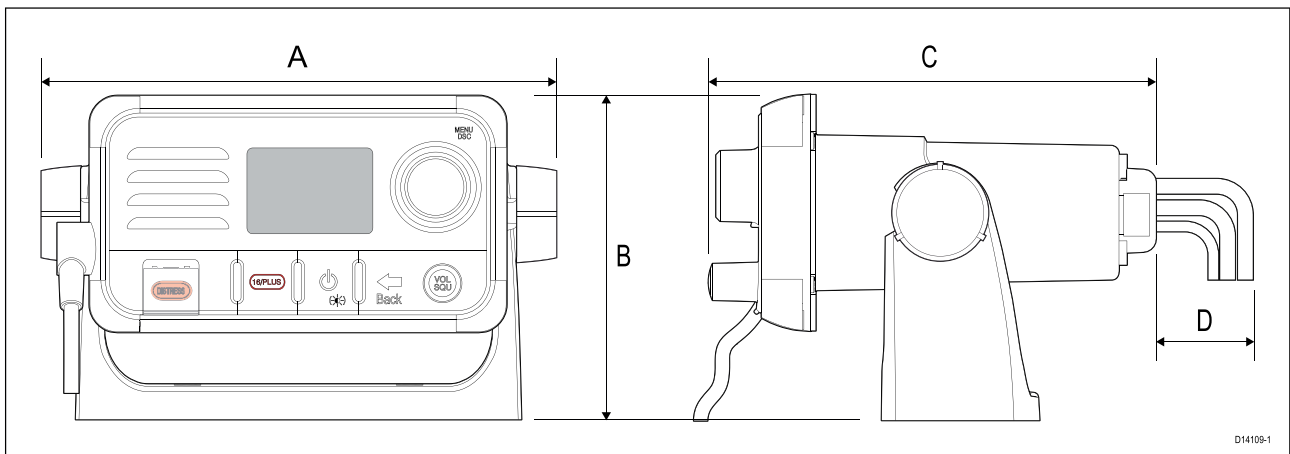

| | |
|---|-------------------|
| A | 192.5 mm (7.6 in) |
| B | 121 mm (4.8 in) |

| | |
|---|--------------------|
| C | 173.75 mm (6.8 in) |
| D | 25 mm (1 in) |

Product dimensions — Ray63 / Ray73

Panel mount dimensions

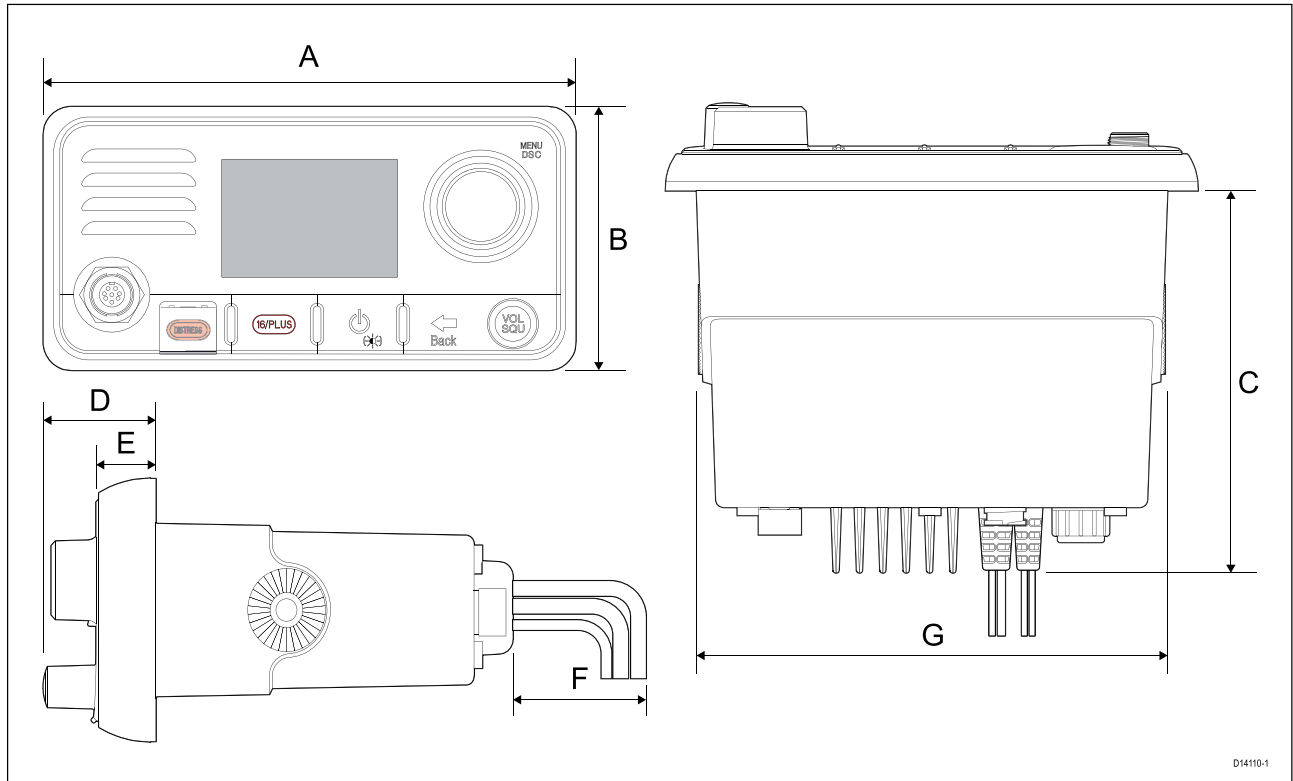

D14110-1

| | |
|---|-------------------|
| A | 199 mm (7.83 in) |
| B | 98.5 mm (3.88 in) |
| C | 143 mm (5.63 in) |
| D | 61.6 mm (2.43 in) |
| E | 16.6 mm (0.65 in) |
| F | 90 mm 3.54 in) |
| G | 176 mm (6.93 in) |

Bracket mount dimensions

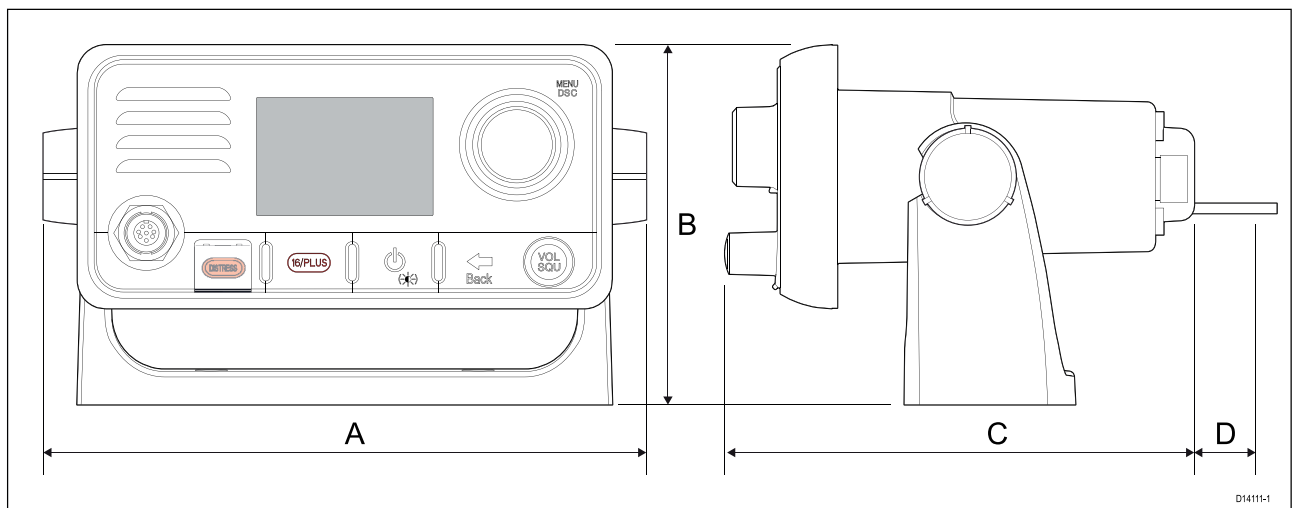

D14111-1

| | |
|---|--------------------|
| A | 226 mm (8.89 in) |
| B | 133 mm (5.24 in) |
| C | 204.6 mm (8.05 in) |
| D | 90 mm (3.54 in) |

A maximum cable bend radius of 90 mm (3.54 in) is required to allow for the handset cable connector.

Product dimensions — Fistmic

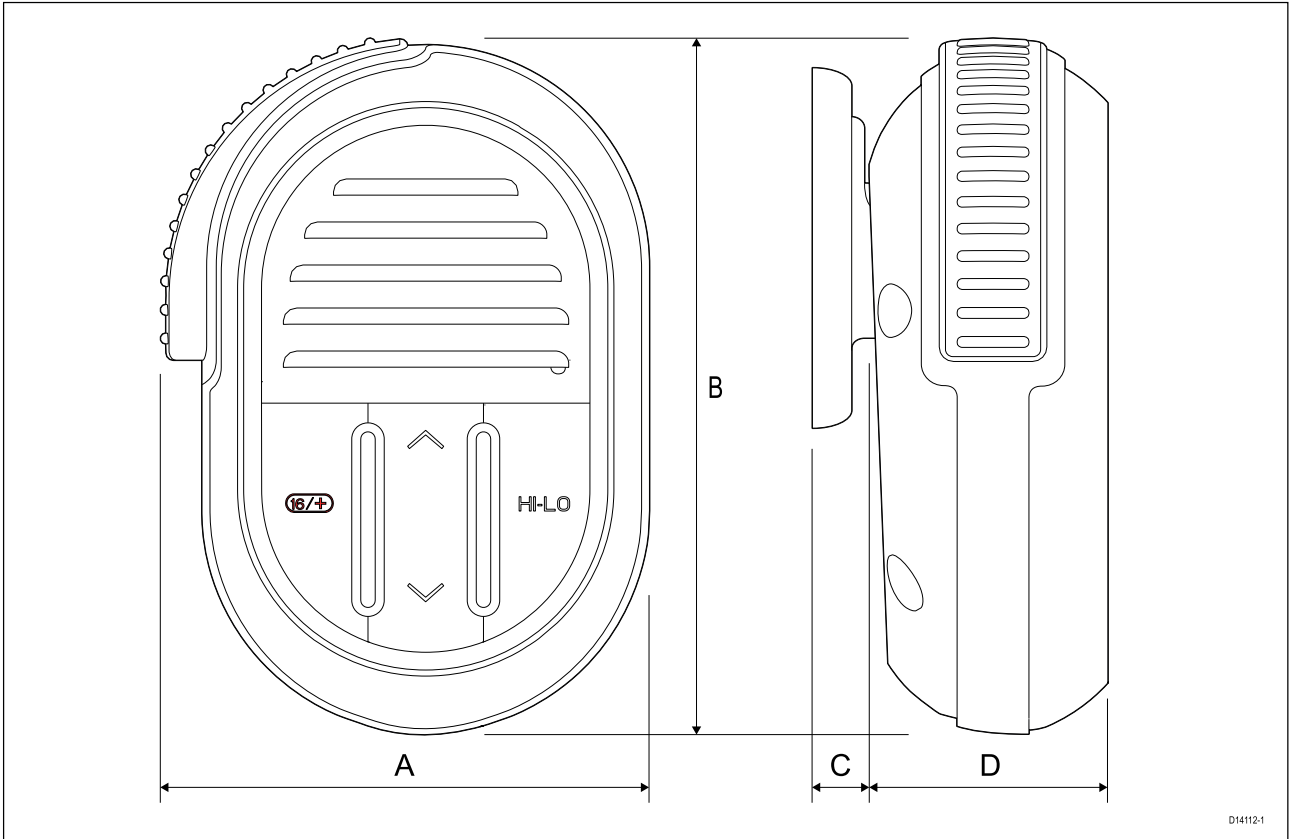

| | |
|---|------------------|
| A | 68.5 mm (2.7 in) |
| B | 97.6 mm (3.8 in) |
| C | 8 mm (0.3 in) |
| D | 36 mm (1.4 in) |

The Fistmic's fitted, coiled lead can be extended comfortably to approximately 1 meter (3.3 ft.)

Product dimensions - Wired handset (Raymic)

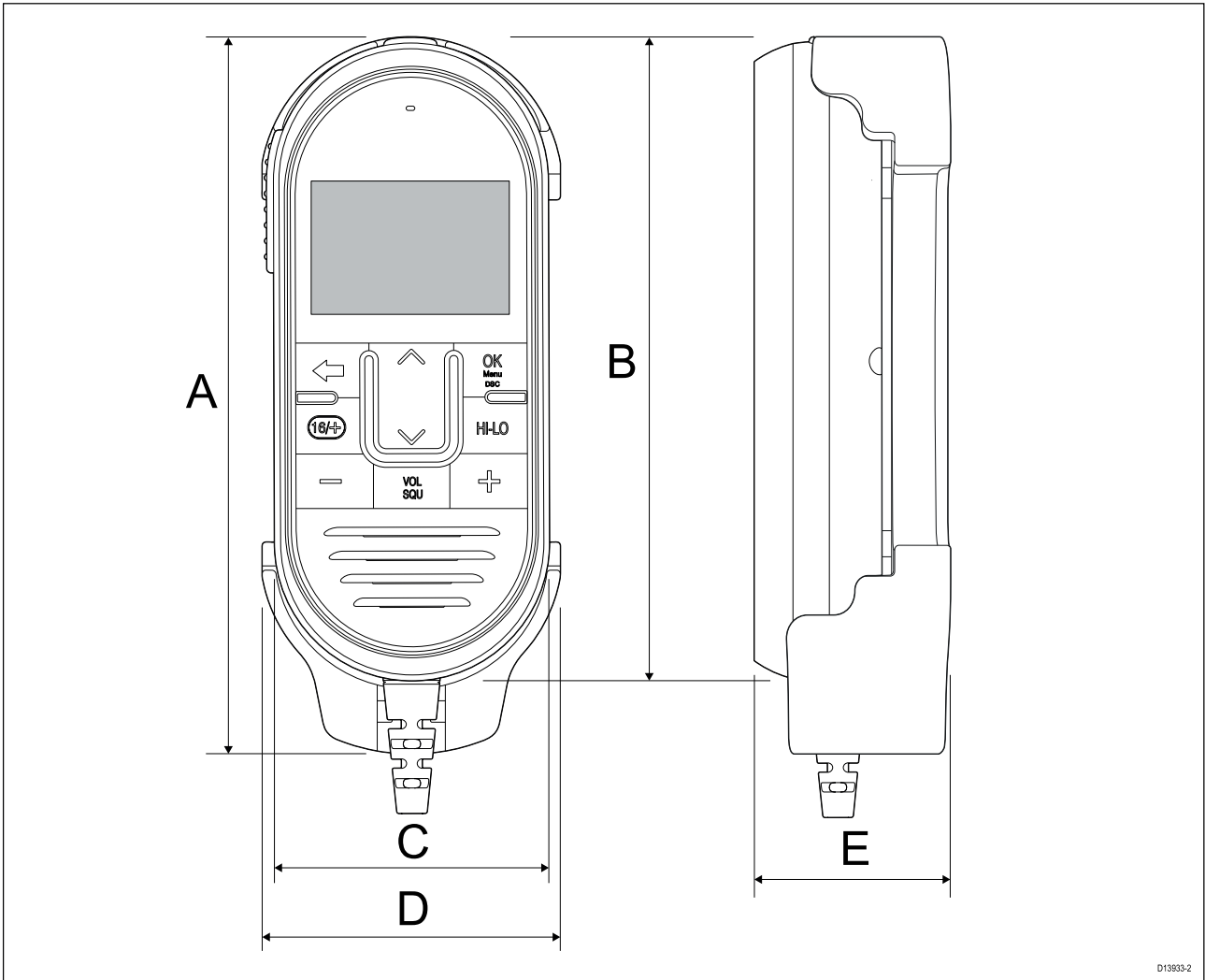

D13833-2

| | |
|---|---------------------|
| A | 167.34 mm (6.59 in) |
| B | 151 mm (5.94 in) |
| C | 66.9 mm (2.63 in) |
| D | 70 mm (2.76 in) |
| E | 46.7 mm (1.84 in) |

The Handset's fitted, coiled lead can be extended comfortably to approximately 1 meter (3.3 ft.). Ensure sufficient space is available below the desired mounting area to accommodate the cable.

Product dimensions - speakers

The dimensions for the Passive and Active speakers are shown below.

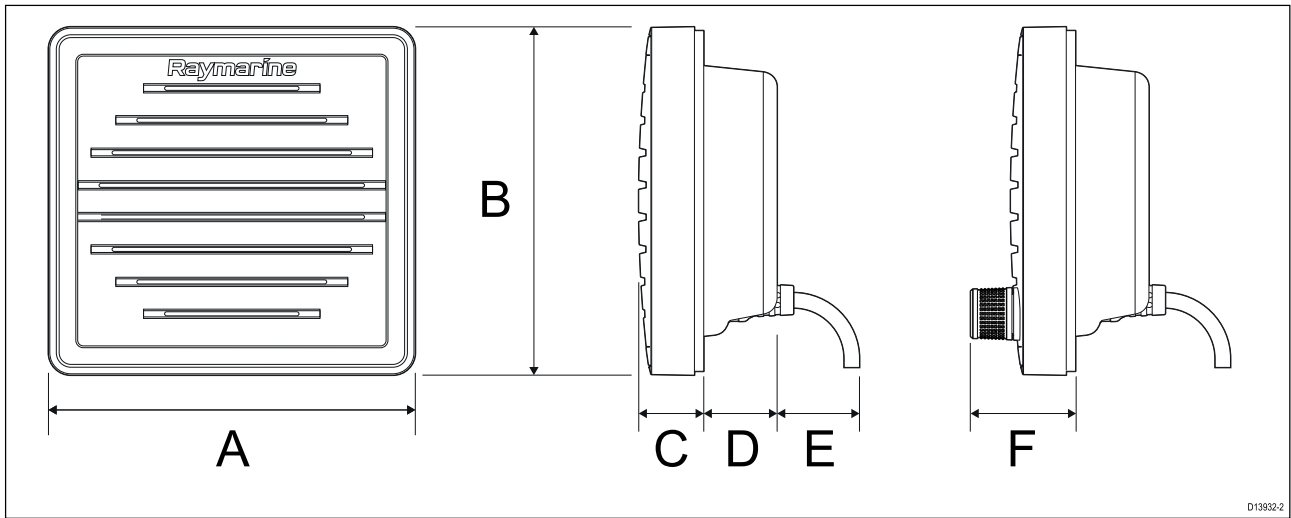

D13932-2

| | |
|---|--------------------|
| A | 118.5 mm (4.67 in) |
| B | 112.5 mm (4.43 in) |
| C | 18.3 mm (0.72 in) |
| D | 26.4 mm (1.04 in) |
| E | 25 mm (0.98 in) |
| F | 30.6 mm (1.20 in) |

The Passive speaker includes a fitted 2 m (6.56 ft) audio cable terminated with a male RCA plug.

The Active speaker includes a fitted 2 m (6.56 ft) power cable terminated with a spade connectors.

Product dimensions - Wireless hub

The dimensions for the wireless hub are shown below.

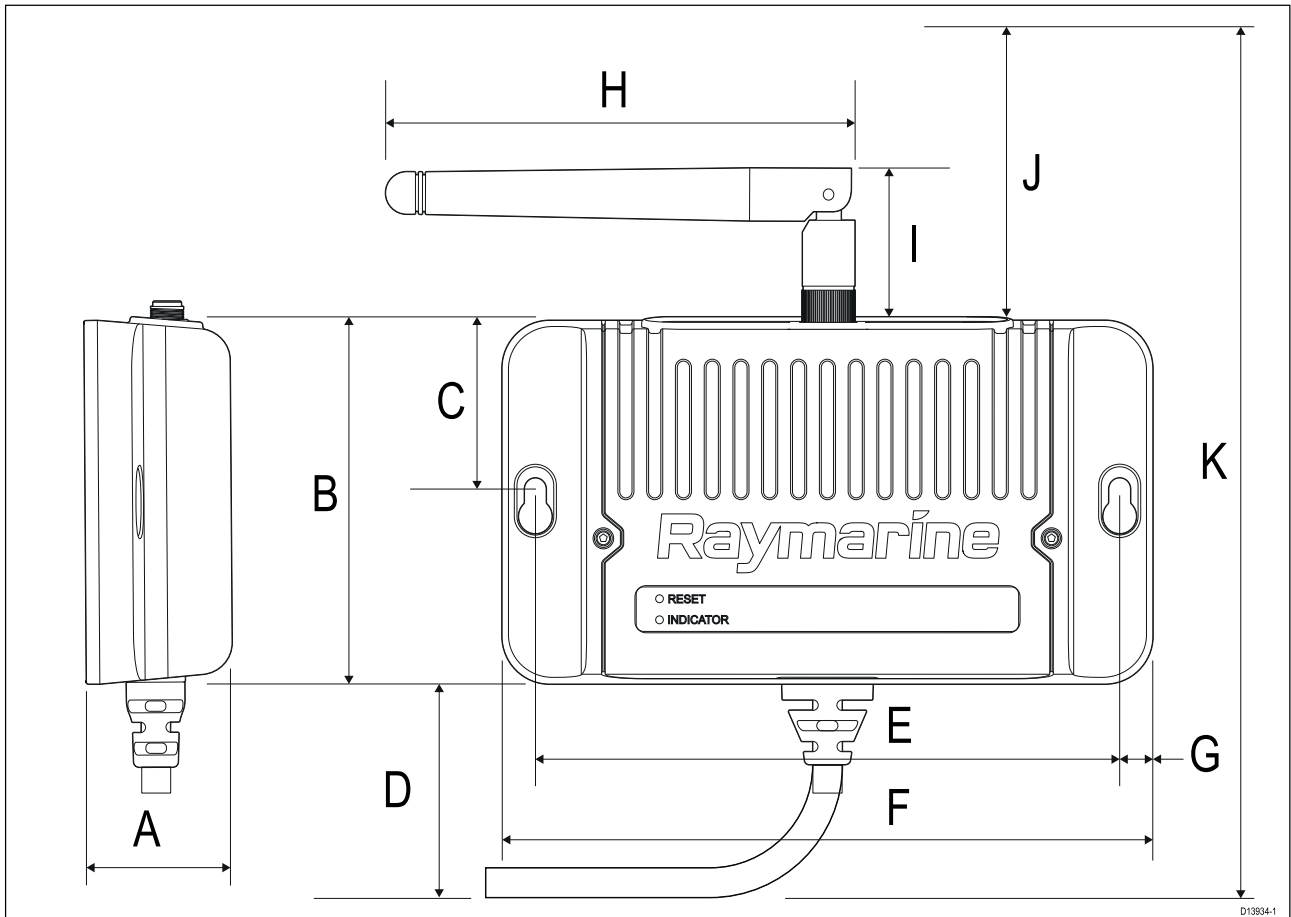

D13934-1

| | |
|---|-------------------------|
| A | 26.7 mm (1.05 in) |
| B | 68.04 mm (2.68 in) |
| C | 32.16 mm (1.27 in) |
| D | 70 mm (2.76 in) |
| E | 109.2 mm (4.30 in) |
| F | 121.6 mm (4.79 in) |
| G | 6.2 mm (0.24 in) |
| H | 87.72 mm (3.45 in) |
| I | 29.14 mm (1.15 in) Min |
| J | 106.95 mm (4.21 in) Max |
| K | 244.99 mm (9.65 in) |

The Wireless hub includes a fitted 5 m (16.4 ft) cable for connection to your VHF Radio.

If the installation requires the cable to be passed through a bulkhead or panelling a 20 mm (0.79 in) diameter hole is required to allow the connector to pass through.

Product dimensions - Wireless handset and holster

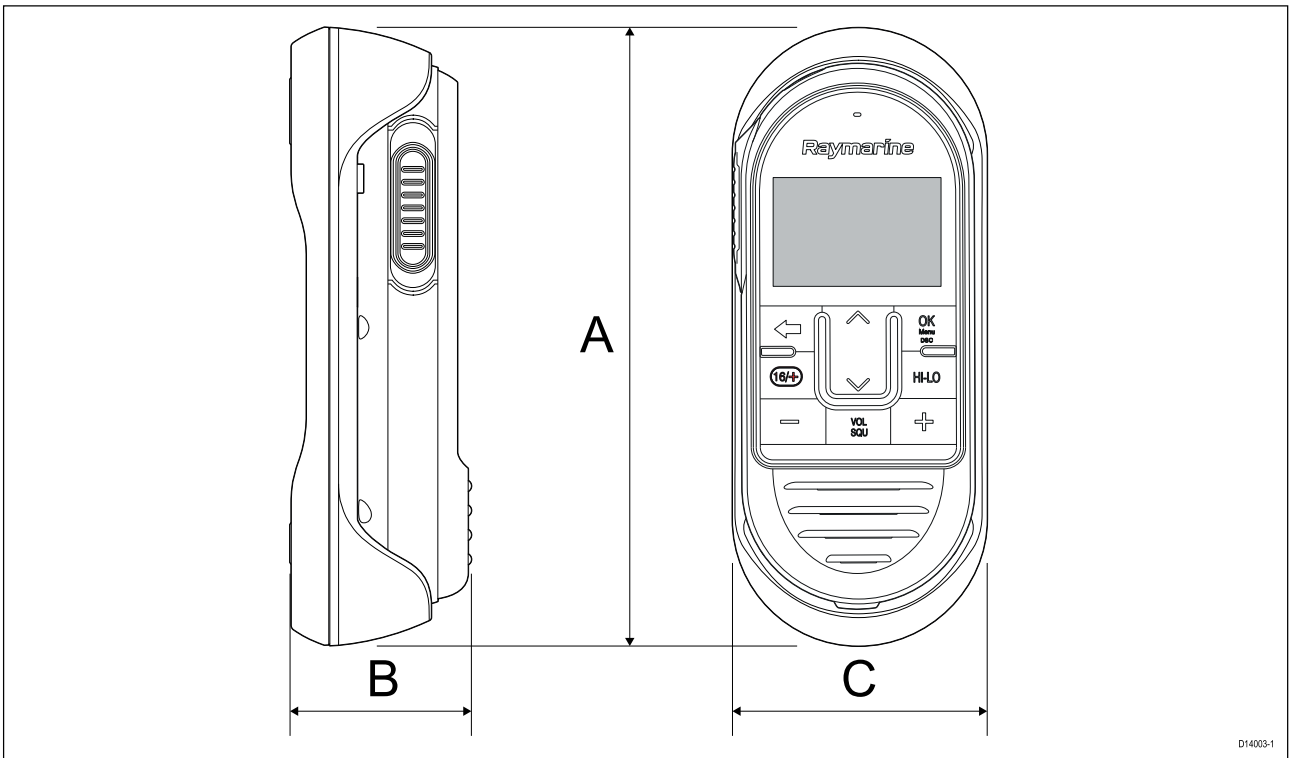

| | |
|---|---------------------|
| A | 173.33 mm (6.82 in) |
| B | 50.5 mm (1.99 in) |
| C | 71.41 mm (2.81 in) |

The charging holster is supplied with a fitted 2 meter (6.56 ft) power cable terminated with bare ended wires.

3.5 Mounting

Tools required for installation

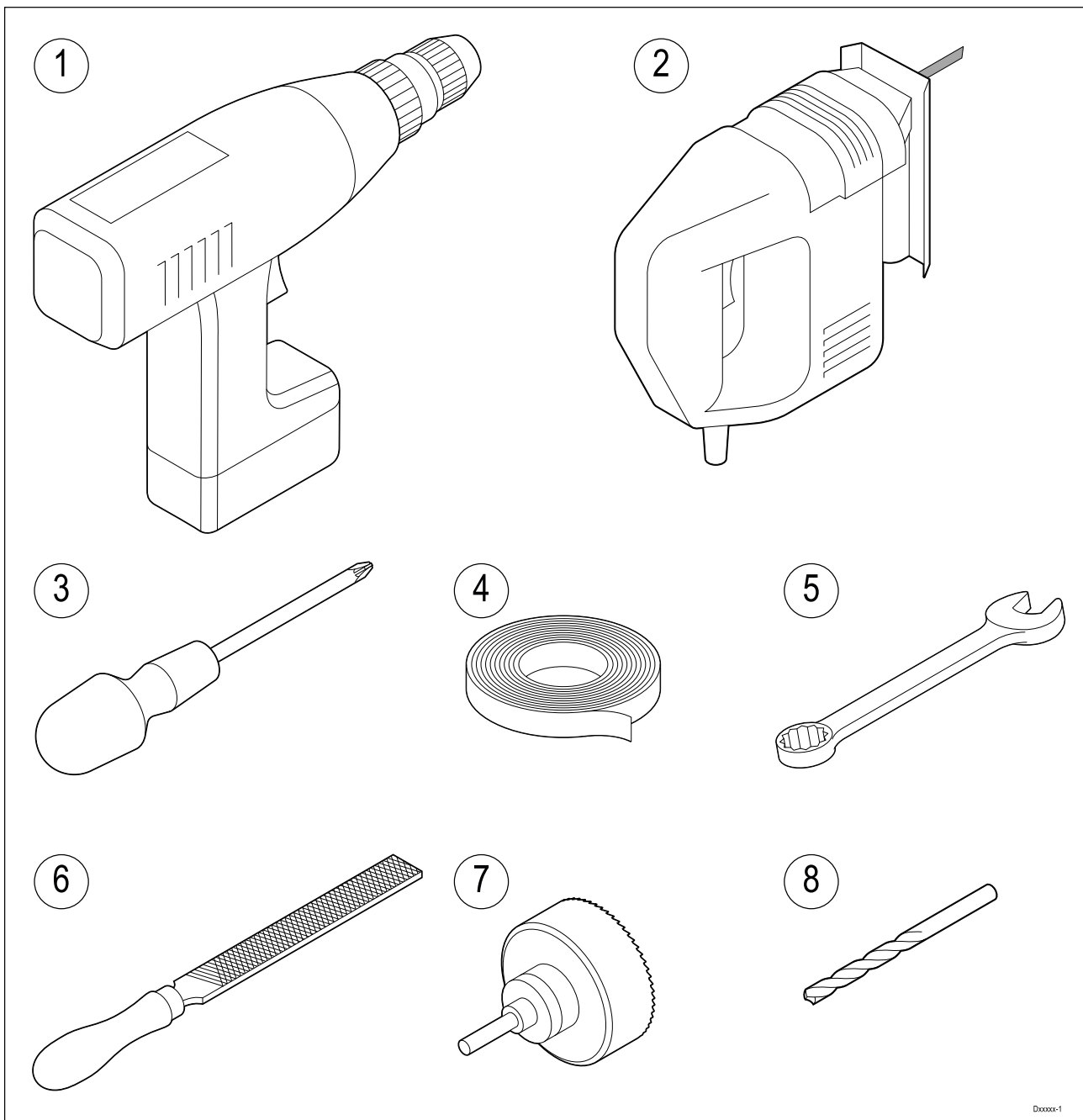

1. Power drill
2. Jigsaw for panel mount cut-out
3. Pozi-drive screwdriver
4. Adhesive tape
5. 7 mm (9/32") Wrench (spanner) for bracket mounting fixings
6. File for panel mount cut out
7. Hole saw for panel mounting (For hole saw size refer to your product's mounting template)
8. Drill bit for surface mounting or bracket mounting

Mounting options

The product can be mounted in the following configurations.

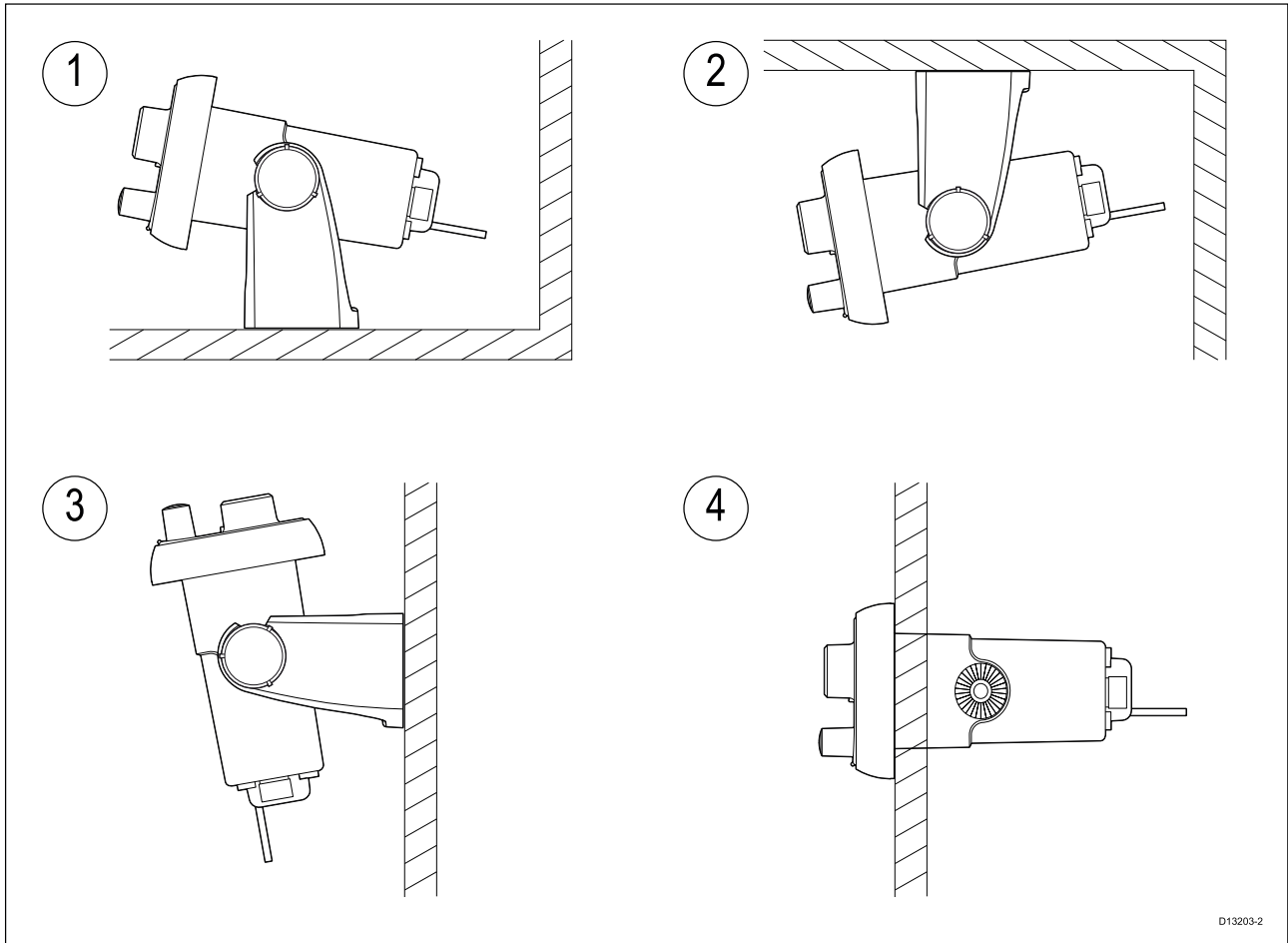

1. Bracket mount — Table top
2. Bracket mount — Overhead
3. Bracket mount — Bulkhead
4. Panel mount

Bracket mounting

Follow the steps below to mount the product on it's bracket.

Before mounting the unit ensure that you have:

- Selected a suitable location, ensuring there is nothing behind the mounting surface that may be damaged when drilling.
- Identified the cable connections and route that the cables will take.
- Attached the front bezel.

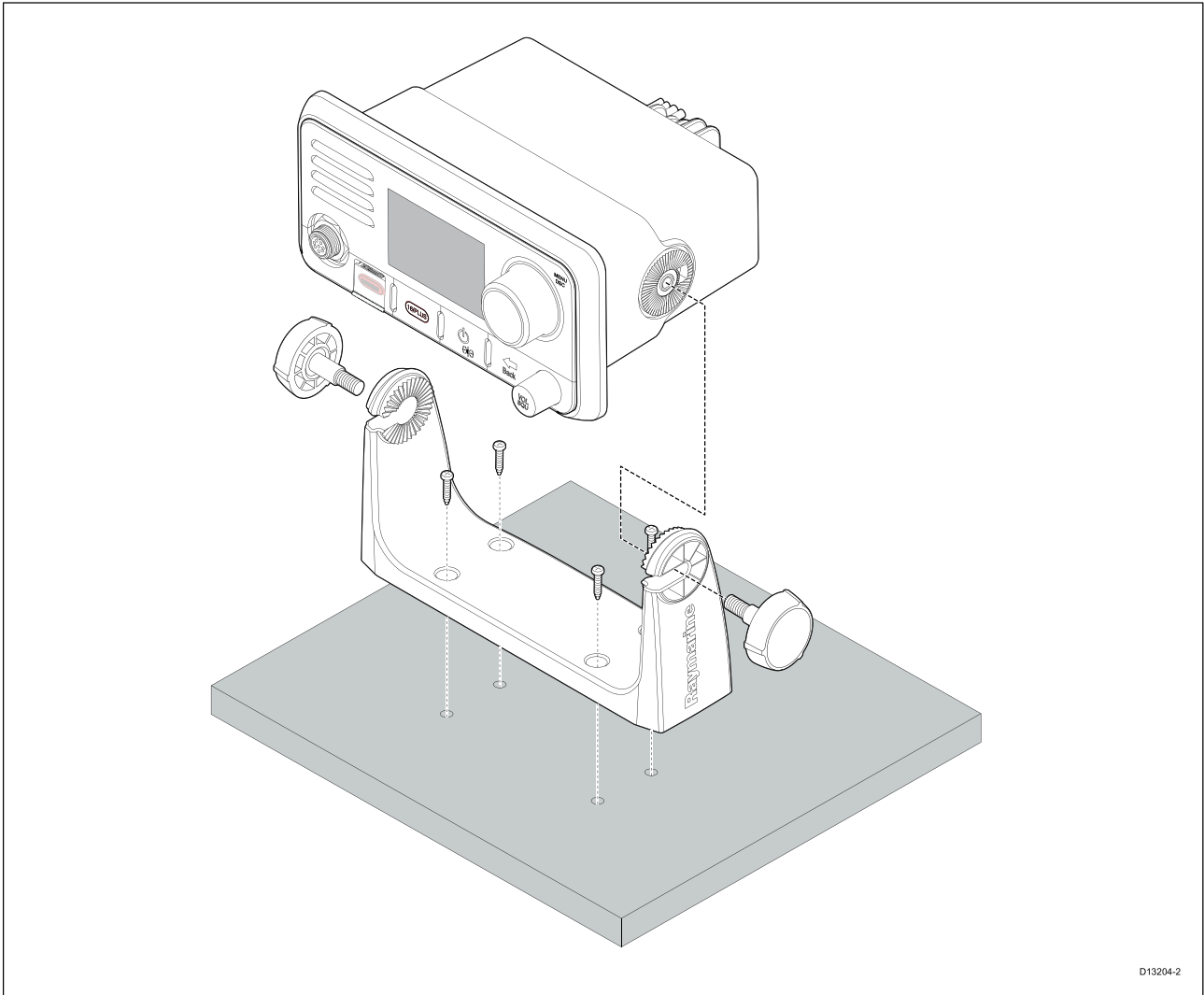

1. Mark the location of the bracket mounting holes on the mounting surface.
2. Drill holes for the mounting fixings using a drill with a suitable sized drill bit.
3. Use the fixings provided to attach the bracket securely to the mounting surface.
4. Attach the unit to the bracket and secure in place using the bracket mounting knobs.

Note:

Drill bit, tap size and tightening torque is dependent on the thickness and type of material the unit is to be mounted on.

Panel mounting — Ray53

Removing the mounting hole covers

Before the radio can be panel mounted the mounting hole covers must be removed.

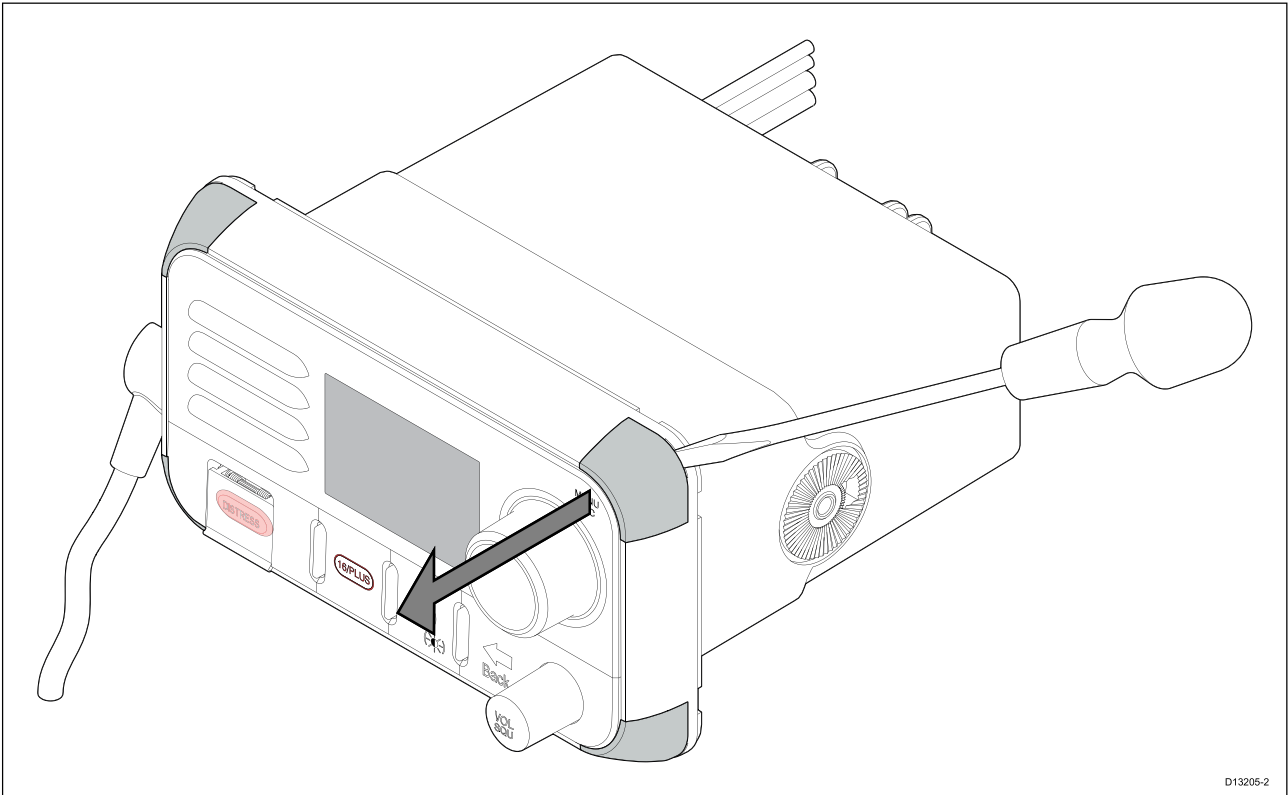

D13205-2

1. Using a flat blade screw driver, insert the tip of the screw driver in the slot between the back of the cover and the unit.
2. Carefully lever the cover forward away from the unit.
3. Repeat steps 1 and 2 for the remaining mounting hole covers.

Drilling out the mounting holes

When panel mounting the radio the mounting holes must be drilled out.

Guides for the mounting holes can be found on the corners of the unit, under the mounting hole covers.

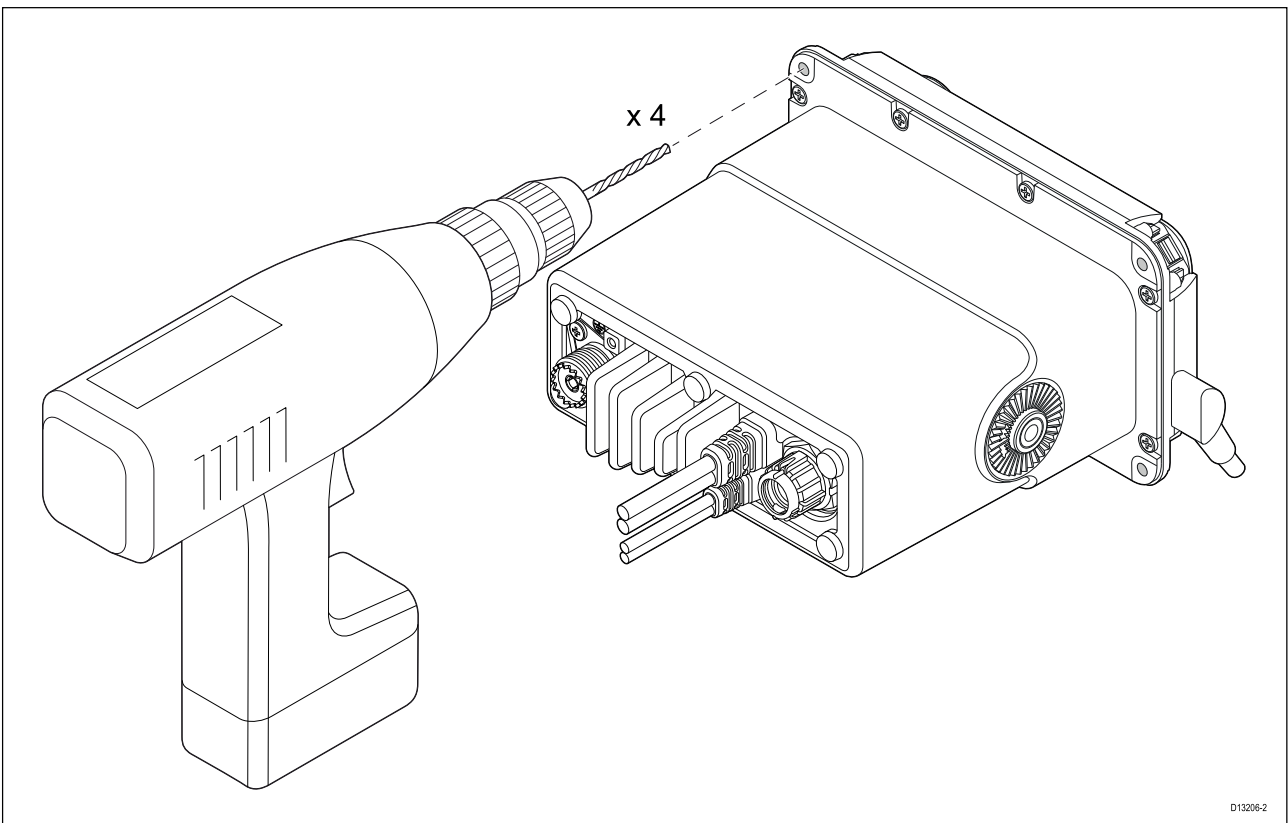

D13205-2

1. Using a drill and a 4 mm (5/32) drill bit, drill out the 4 mounting holes.

Holes should be drilled from the front of the unit, taking care not to apply too much force to the drill.

Panel mounting

To panel mount the radio follow the steps below.

Before mounting the product, ensure that you have:

- Selected a suitable location, ensuring there is nothing behind the mounting surface that may be damaged when drilling / cutting.
- Identified the cable connections and route that the cables will take.
- Removed the mounting hole covers.
- Drilled out the mounting holes on the unit.

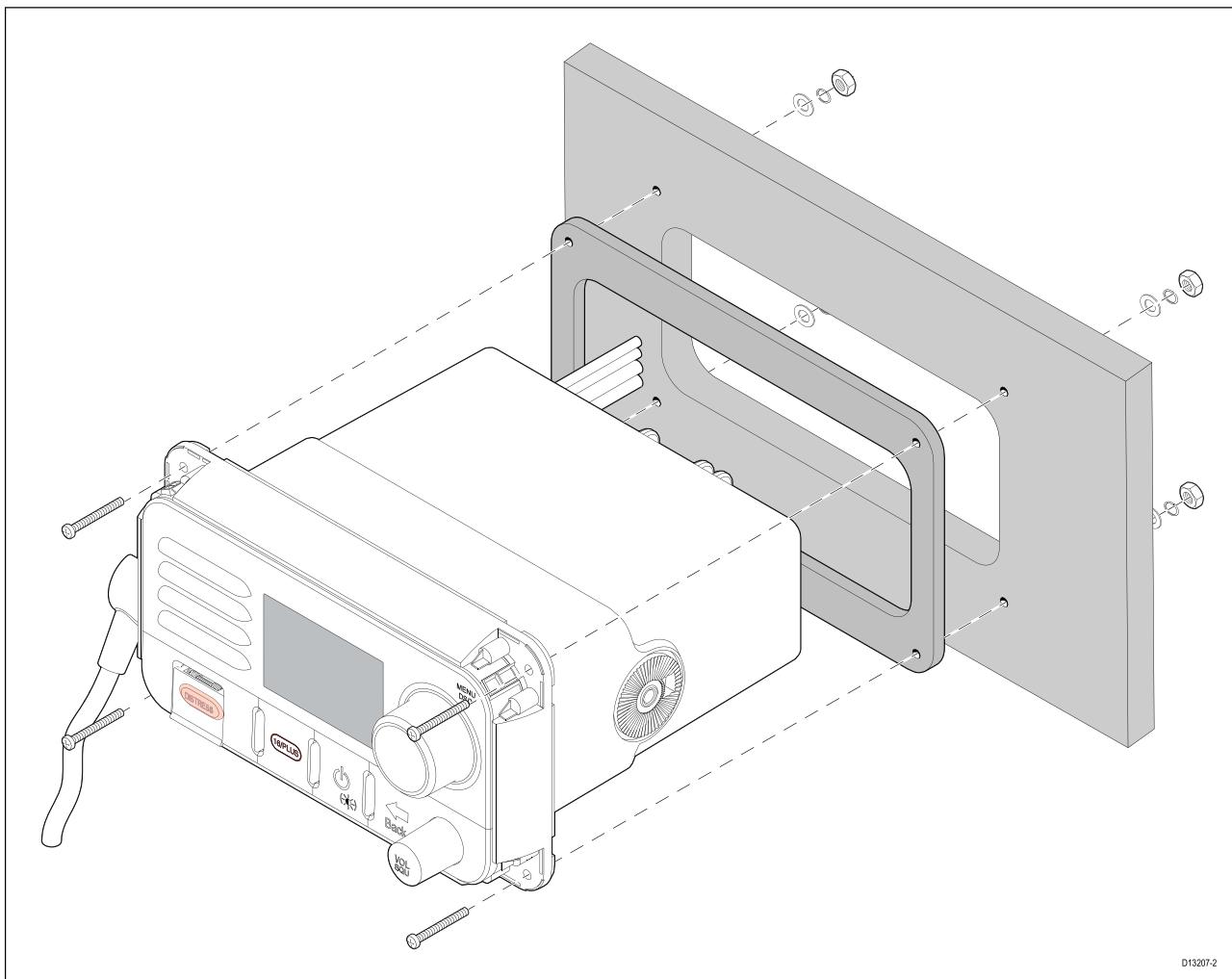

1. Check the selected location for the unit. A clear, flat area with suitable clearance behind the panel is required.
2. Fix the supplied mounting template to the selected location, using masking or self-adhesive tape.
3. Using a suitable hole saw (the size is indicated on the template), make a hole in each corner of the cut-out area.
4. Using a suitable saw, cut along the inside edge of the cut-out line.
5. Ensure that the unit fits into the removed area and then file around the rough edge until smooth.
6. Drill 4 holes as indicated on the template to accept the fixings.
7. Remove the backings from the supplied gasket.
8. Place the gasket in position on the back of the unit and press firmly onto the flange.
9. Connect the power, and other cables to the unit.
10. Slide the unit into place and secure using the fixings provided.

11. Attach the mounting hole covers.

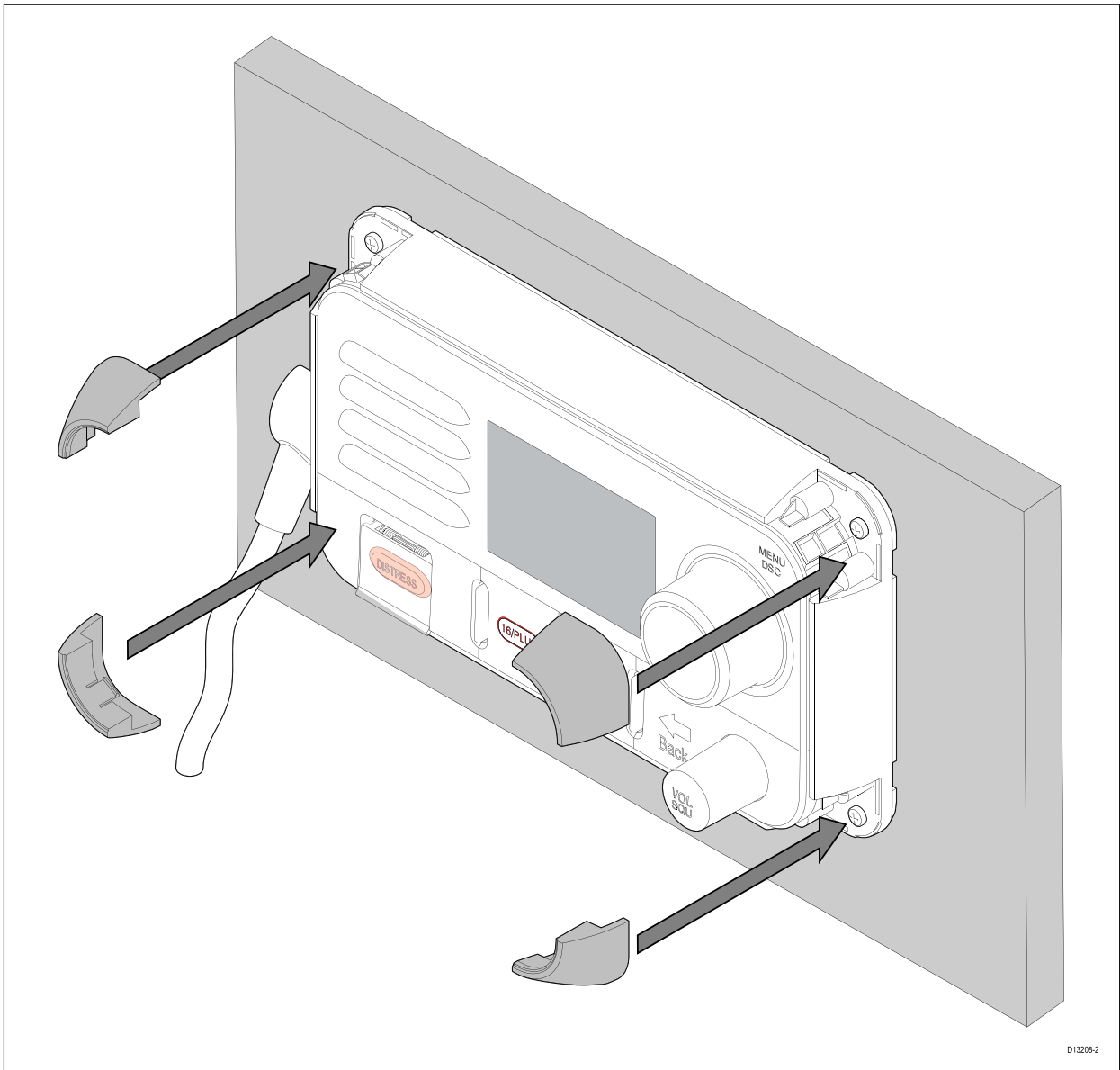

Note:

The supplied gasket provides a seal between the unit and a suitably flat and stiff mounting surface or binnacle. The gasket should always be used. It may also be necessary to use a marine-grade sealant if the mounting surface or binnacle is not entirely flat and stiff or has a rough surface finish.

Panel mounting — Ray63 / Ray73

Drilling out the mounting holes

Before panel mounting the Radio the mounting holes must be drilled out.

Guides for the mounting holes can be found in the corners of the unit, under the front bezel.

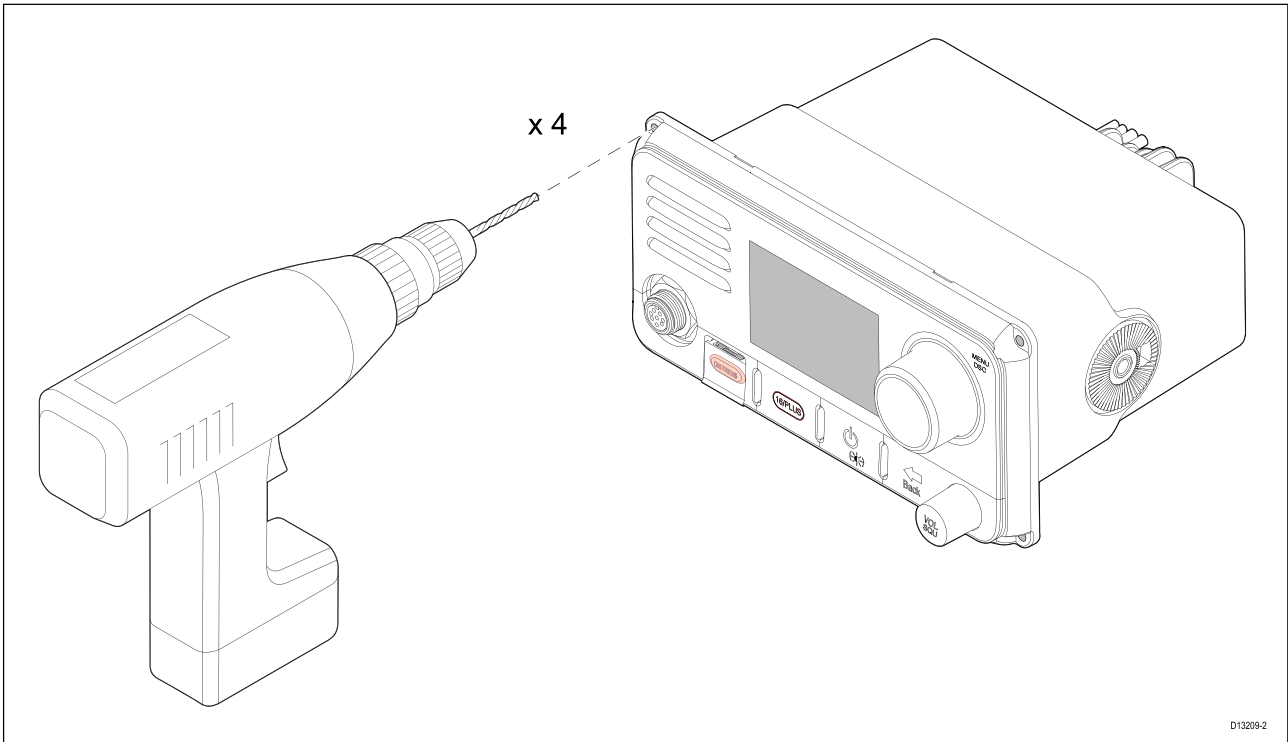

1. Using a drill and a 4 mm (5/32) drill bit, drill out the 4 mounting holes.

Holes should be drilled from the front of the unit, taking care not to damage the unit by applying too much force to the drill.

Panel mounting

To panel mount the Radio follow the steps below.

Before mounting the product, ensure that you have:

- Selected a suitable location, ensuring there is nothing behind the mounting surface that may be damaged when drilling / cutting.
- Identified the cable connections and route that the cables will take.
- Drilled out the mounting holes on the unit.
- Removed the front bezel.

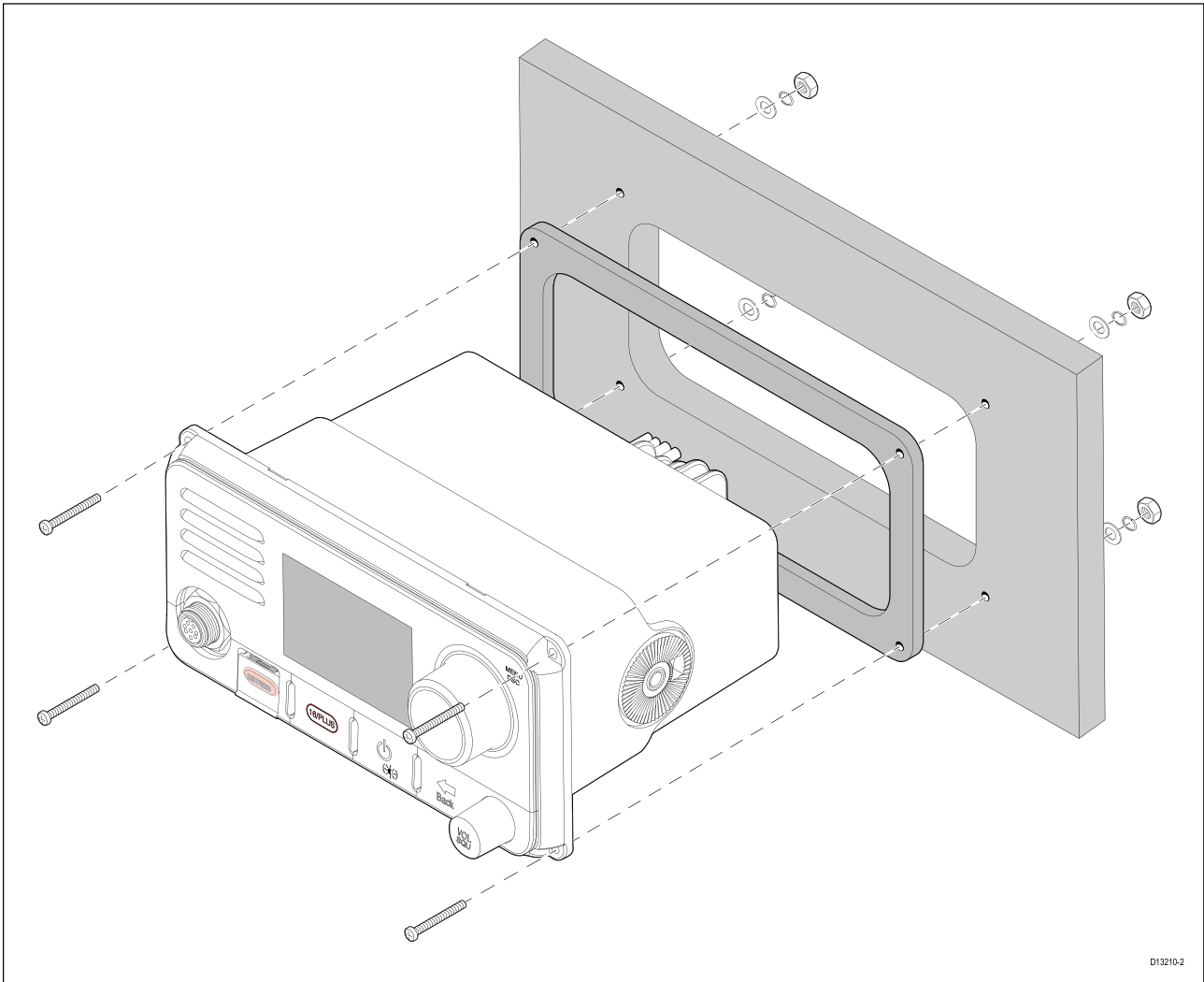

D13210-2

1. Check the selected location for the unit. A clear, flat area with suitable clearance behind the panel is required.
2. Fix the supplied mounting template to the selected location, using masking or self-adhesive tape.
3. Using a suitable hole saw (the size is indicated on the template), make a hole in each corner of the cut-out area.
4. Using a suitable saw, cut along the inside edge of the cut-out line.
5. Ensure that the unit fits into the removed area and then file around the rough edge until smooth.
6. Drill 4 holes as indicated on the template to accept the fixings.
7. Remove the backings from the supplied gasket.
8. Place the gasket in position on the back of the unit and press firmly onto the flange.
9. Connect the power, and other cables to the unit.
10. Slide the unit into place and secure using the fixings provided.
11. Attach the front bezel.

Note:

The supplied gasket provides a seal between the unit and a suitably flat and stiff mounting surface or binnacle. The gasket should always be used. It may also be necessary to use a marine-grade sealant if the mounting surface or binnacle is not entirely flat and stiff or has a rough surface finish.

Attaching the front bezel

After installation of the Radio the front bezel can be attached following the steps below. The following procedure assumes that the unit has already been mounted in position.

1. Orientate the bottom-right side of the bezel under the bottom-right side of the unit, ensuring that the clips along the bottom edge of the bezel latch into position.

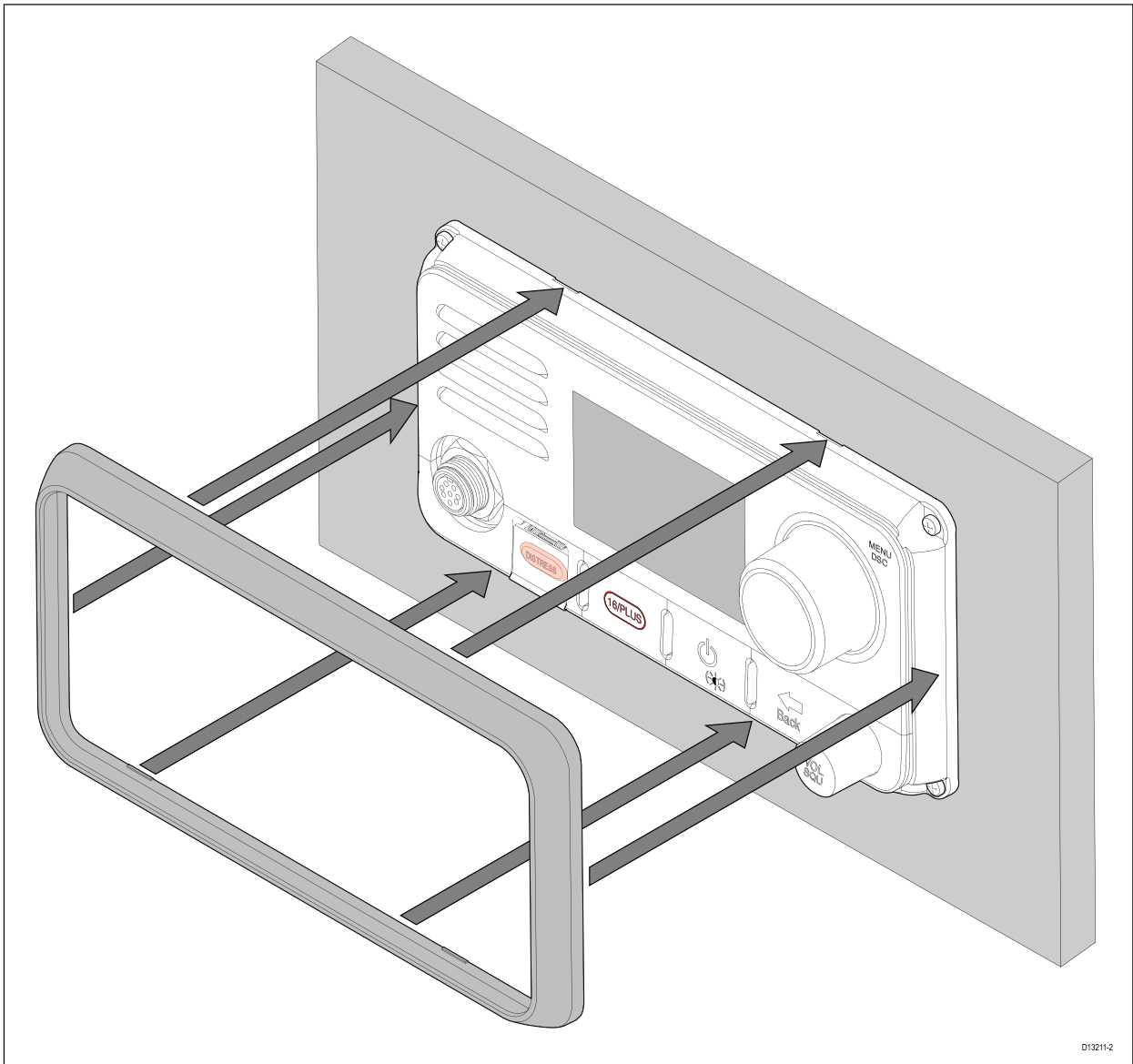

2. Ensure the bezel is correctly aligned with the unit, as shown.
3. Apply firm but even pressure to the bezel along the:
 - i. Outer edges - work from the sides upwards and then along the top edge, to ensure that it clips securely into position.
 - ii. Inner edges - ensure that the bezel sits flat.
4. Check that all control buttons are free to operate.

Fistmic mounting

The Fistmic can be mounted by following the steps below. Whilst only the Fistmic is pictured, you can also mount the Handset using the same Hook plate (mounting clip).

Before mounting the unit, ensure that you have:

- Selected a suitable location, ensuring there is nothing behind the mounting surface that may be damaged when drilling.
- Identified the cable connections and route that the cables will take.

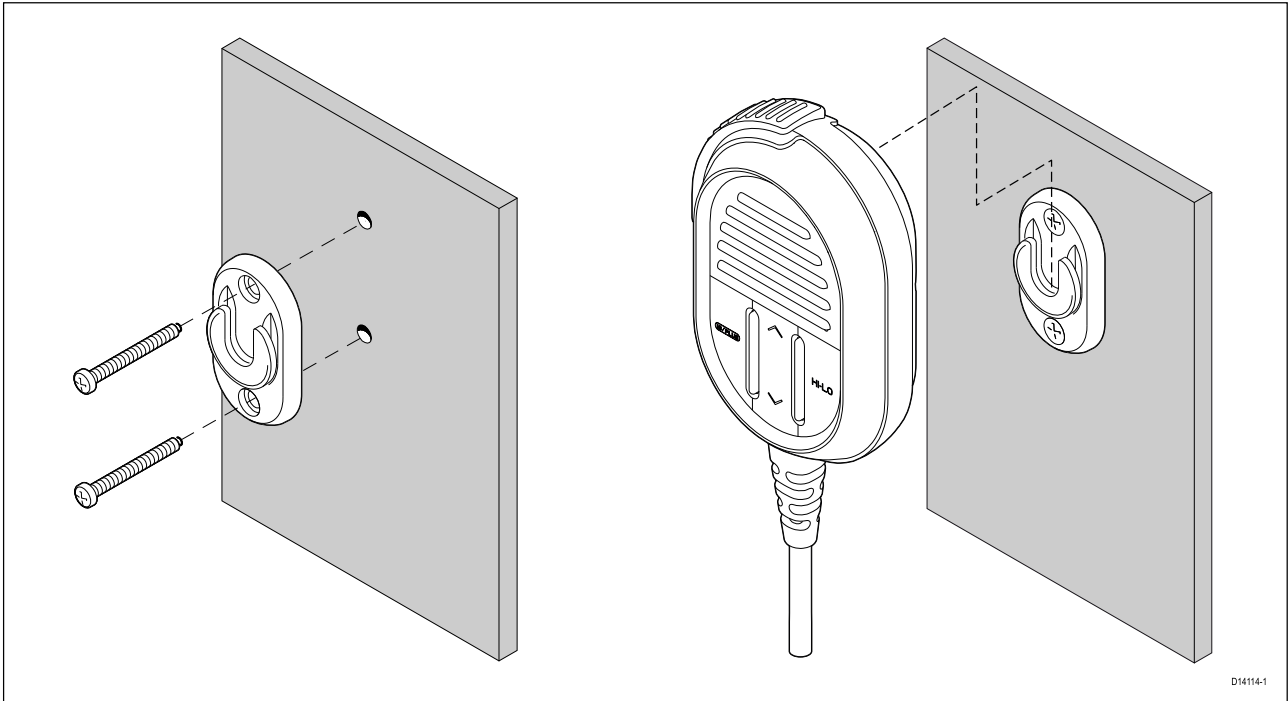

1. Check the selected location for the Hook plate, a clear flat area is required, with sufficient space around it to place and remove the Fistmic / Handset and coiled cable.
2. Using a pencil, offer up the Hook plate to the desired location and mark the location of the screw holes on the mounting surface.
3. Drill the mounting holes using a suitable size drill bit.
4. Hold the Hook plate in place and secure using the screws provided.
5. Hook the Fistmic / Handset over the Hook plate and gently push down until it clicks into position.

Important:

- The Fistmic can only be hooked and unhooked from the Hook plate when held vertically.
- Drill bit, tap size and tightening torque is dependent on the thickness and type of material the unit is to be mounted on.

Wired handset mounting using the holster

Follow the steps below to mount the wired handset.

Before mounting, ensure that your selected location meets the location requirements found in this document.

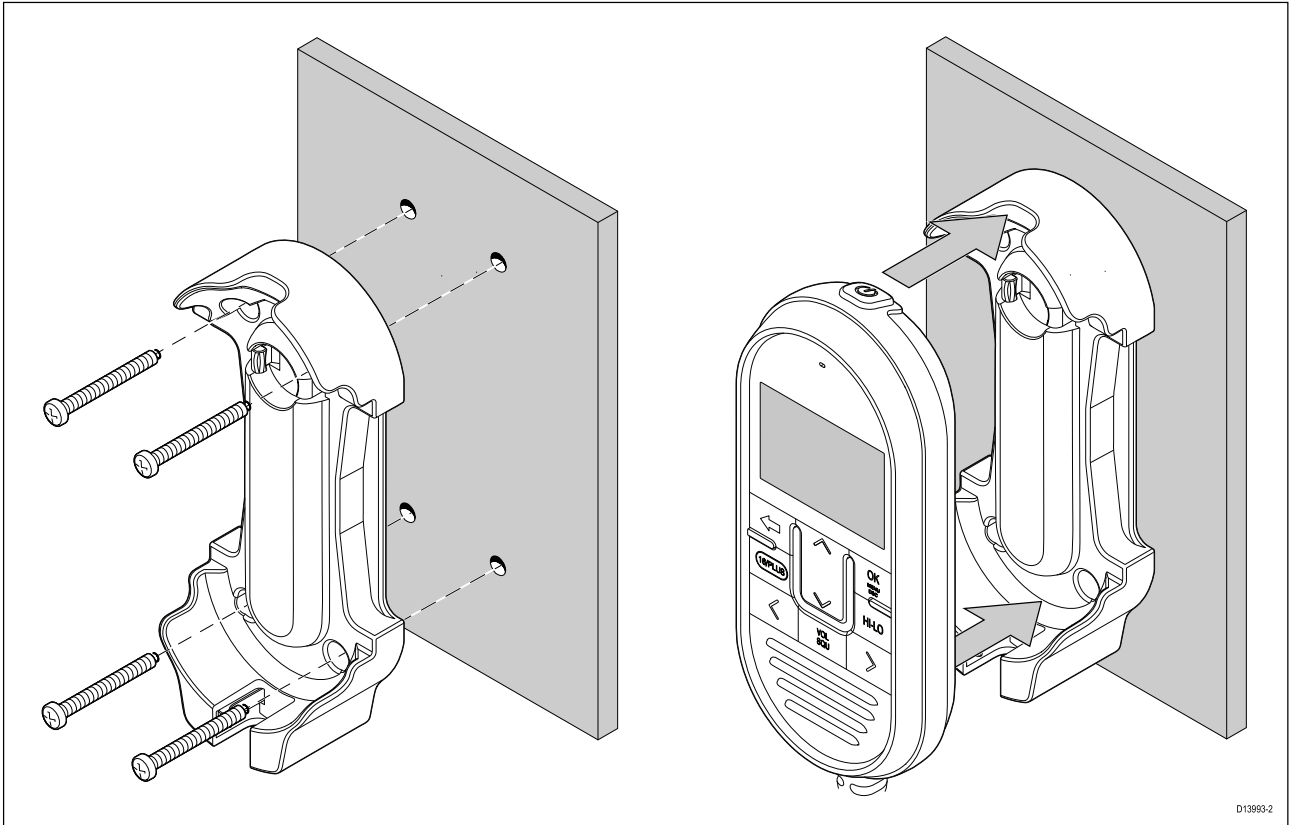

D13993-2

1. Check the selected location for the mounting holster, a clear flat area is required, with sufficient space around it to place and remove the handset.
2. Using a pencil, offer up the holster to the desired location and mark the location of the screw holes on the mounting surface.
3. Drill the mounting holes using a suitable size drill bit.
4. Hold the holster in place and secure using the screws provided.
5. Place the handset into the holster until it clicks into position.

Wired and wireless speaker mounting

Before mounting, ensure that your selected location meets the location requirements found in this document.

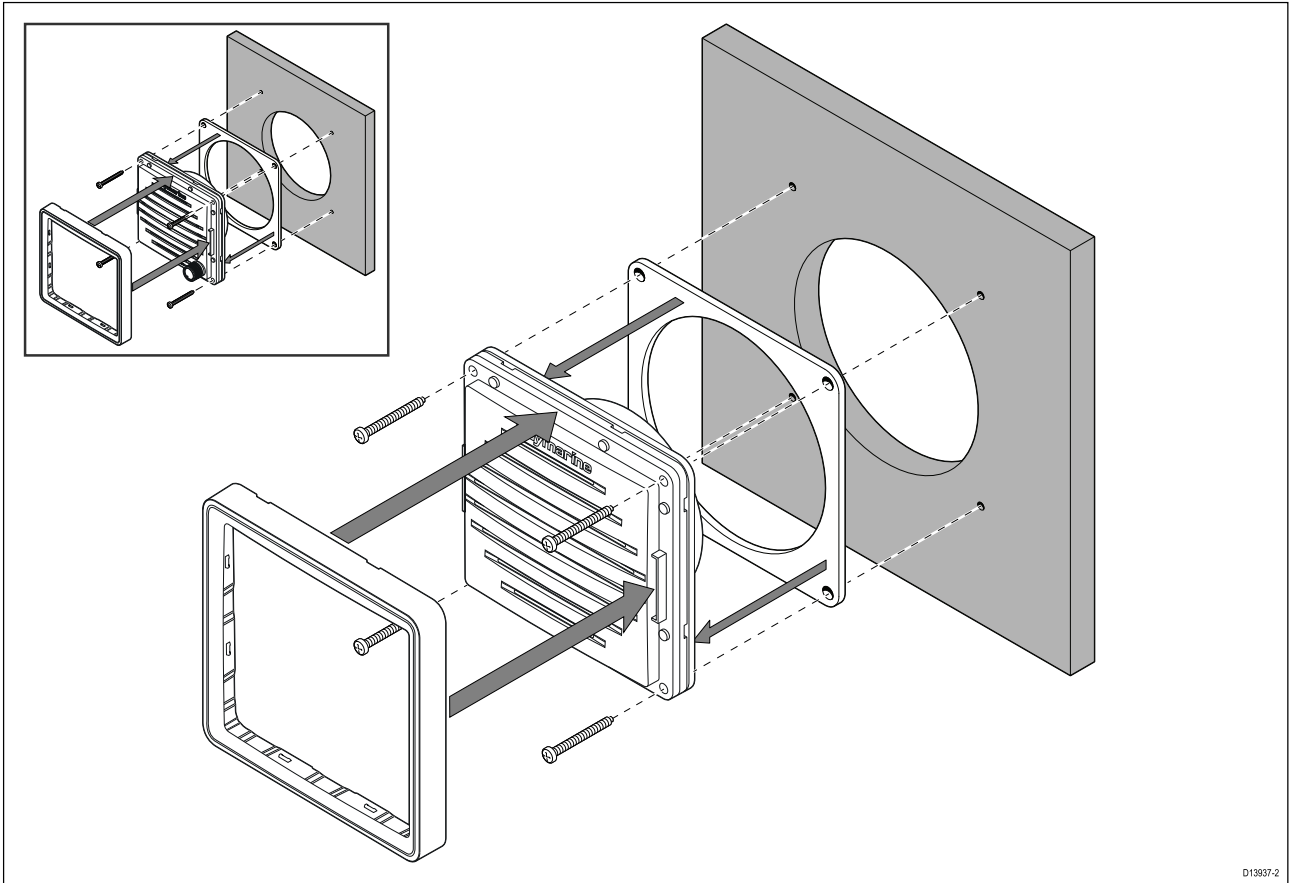

D13937-2

1. Remove the speaker's bezel.
2. Using the supplied mounting template, mark the location of the cut out and fixing holes on the mounting surface.
3. Using a 89 mm (3 ½ in) hole saw, drill out the centre cut out area indicated on the mounting template.
4. Drill holes for the fixings, using a drill with a suitable sized bit.
5. Ensure that the unit fits into the removed area and then file around the cut edge until smooth.
6. Peel the backing off of the supplied gasket and place the adhesive side of the gasket onto the rear of the speaker, pressing firmly onto the flange.
7. Connect the relevant cable to the speaker.
8. Slide the speaker into place and secure using the fixings provided.
9. Fit the Bezel, ensuring it clips into place on all 4 sides.

Pass-through panel kit mounting

When installing handsets, the pass-through panel kit should be used to secure the cable's connector to the panel the cable has to pass through.

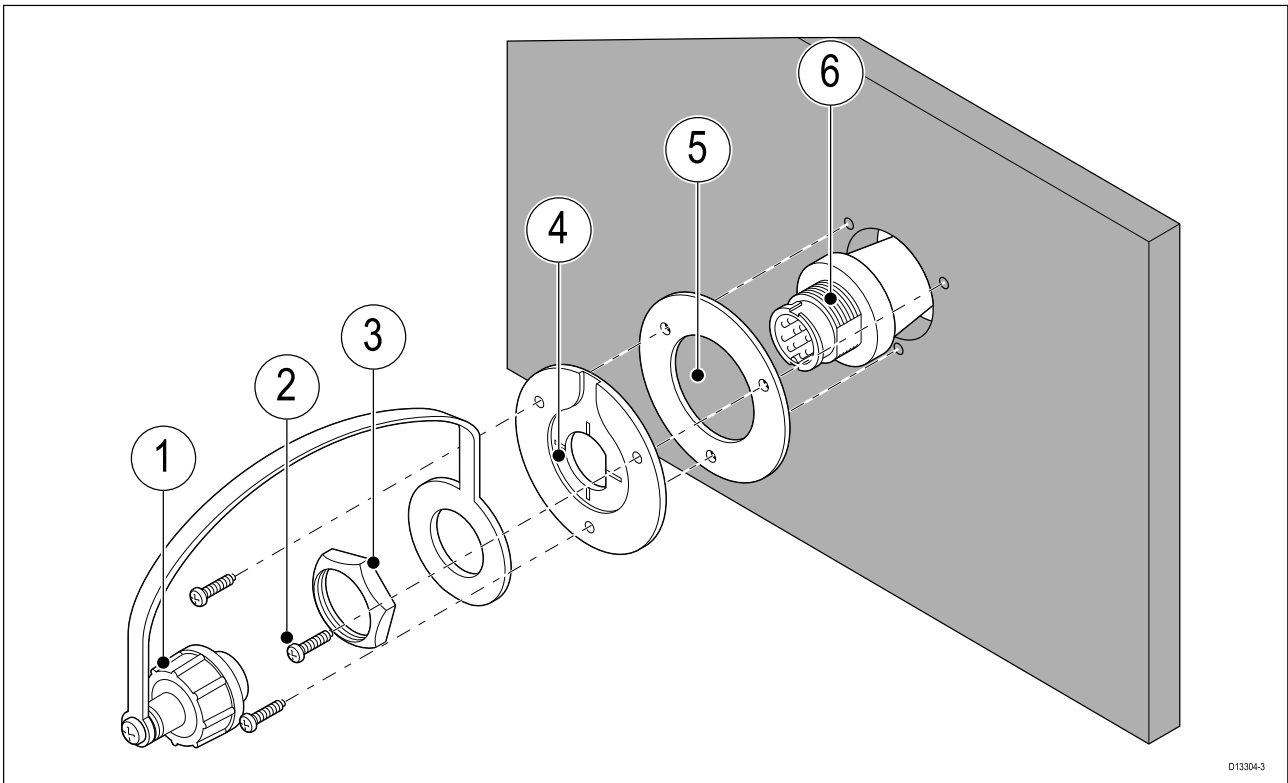

| | |
|---|------------------------------------|
| 1 | Splash-proof dust cap with lanyard |
| 2 | Mounting plate fixings x 3 |
| 3 | Mounting plate nut |
| 4 | Mounting plate |
| 5 | Mounting plate gasket |
| 6 | Extension cable |

1. Check the selected location for the Mounting plate, a clear flat area is required.
2. Ensuring correct orientation of the mounting plate, offer up the plate to the desired location and mark the location of the screw holes and the center hole on the mounting panel.

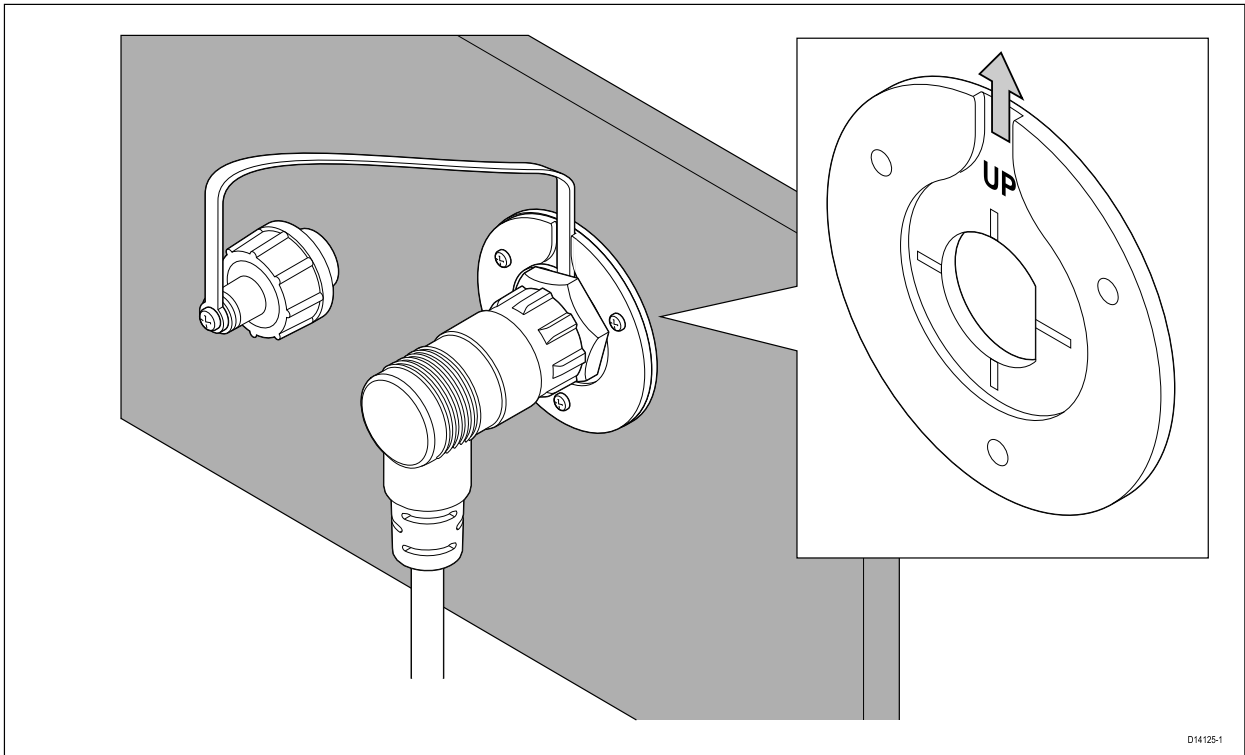

To ensure that the handset's connector points down when connected, orientate the mounting plate so that the lanyard groove is pointing straight up.

3. Drill the mounting holes using a suitable size drill bit.
4. Drill the center hole using a 25 mm (1 in.) hole cutting saw.
5. Pull the connector end of the cable through the hole in the mounting surface.
6. Place the Mounting plate gasket over the end of the connector.
7. With the recessed side facing away from the mounting panel, place the Mounting plate over the end of the connector.
8. Place the lanyard end of the Splash-proof dust cap over the connector, ensuring the lanyard sits in the recess in the Mounting plate.
9. Place the Mounting plate nut over the connector and tighten clockwise using a 13/16 in. (21 mm) socket wrench, being careful not to damage the plastic nut by overtightening.
10. Secure the Mounting plate to the mounting surface using the supplied screws.
11. Attach the Handset / Fismic connector to the cable connector and rotate the locking collar clockwise to secure.
12. Connect the opposite end of the cable to the required connector either on the Base station or to another pass-through panel mounting plate connector.

Note:

Drill bit, tap size and tightening torque is dependent on the thickness and type of material the unit is to be mounted on.

Mounting the wireless hub

Before mounting, ensure that:

- your selected location meets the location requirements found in this document.
- you pay particular attention to the wireless location requirements.
- sufficient space is available above or to one side of the hub for the antenna.
- the product operates correctly at the desired location before mounting.

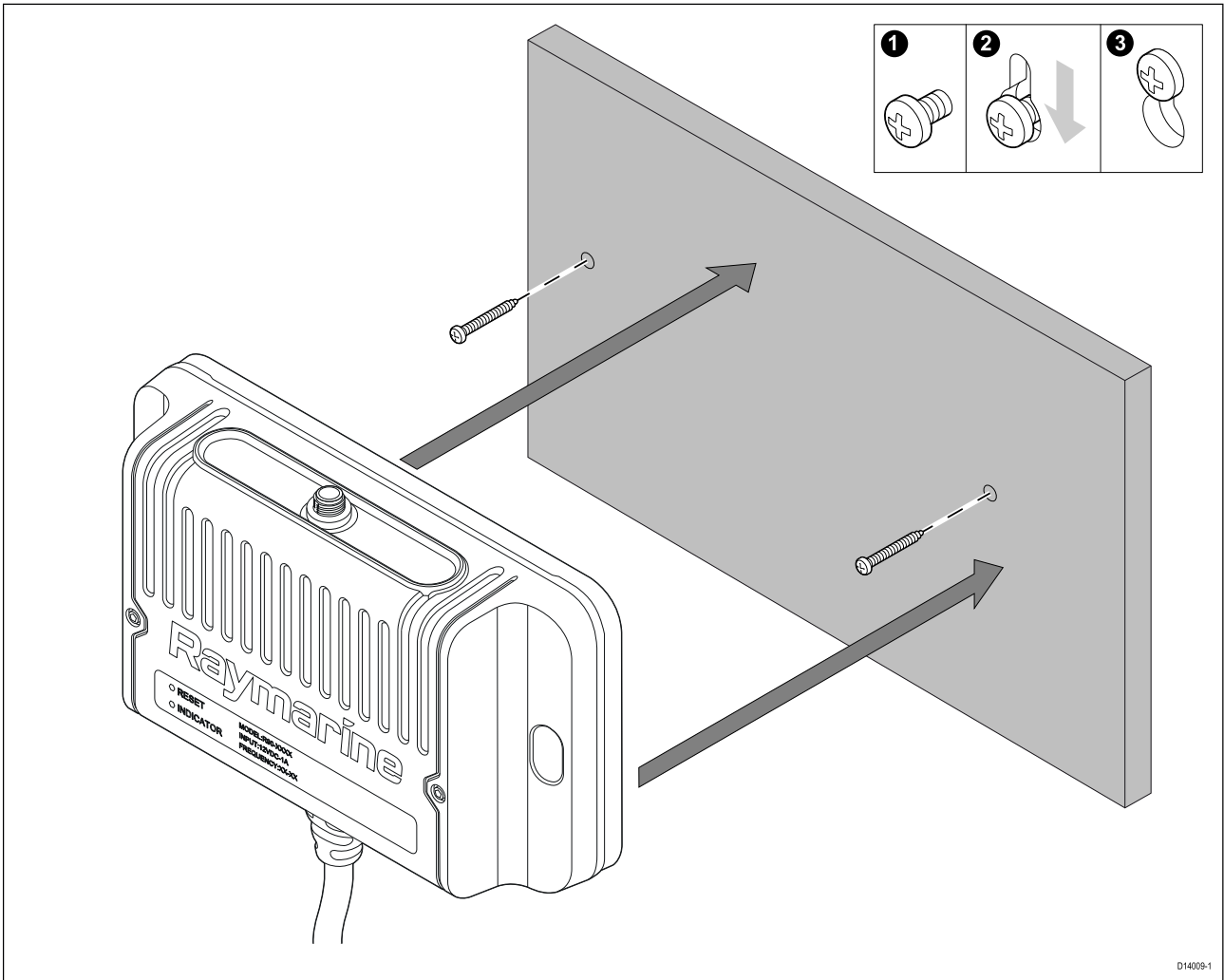

1. Using the supplied mounting template, mark the location of the fixing holes on the mounting surface.
2. Drill holes for the mounting fixings using a drill with a suitable sized drill bit.
3. Screw the fixings approximately half way into the holes in the mounting surface.
4. Place the Wireless hub over the fixing screws and push down to lock into positions
5. Fully tighten the screws.
6. Connect the antenna to the top of the hub.

Antenna orientation

Radio waves are emitted from the wireless hub perpendicular to the orientation of the hub's antenna.

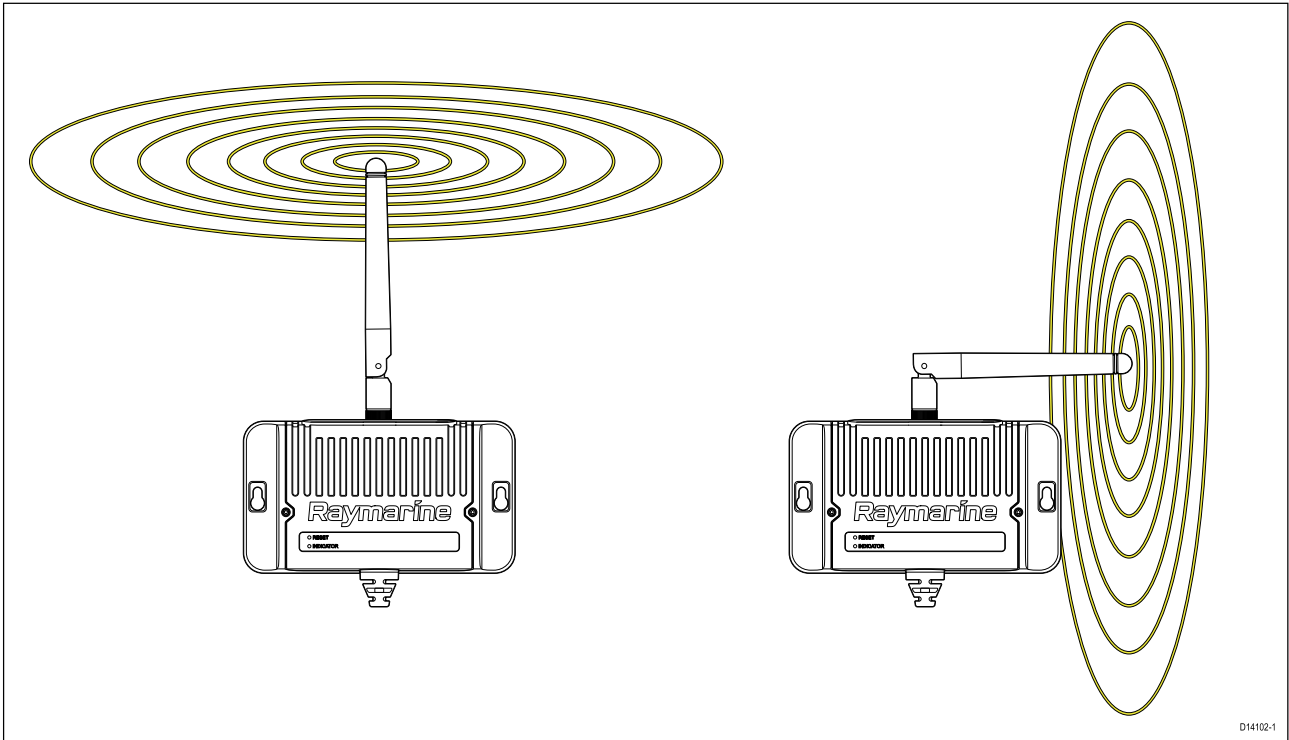

Keeping the antenna vertical should provide the best coverage for devices on the same plane as your hub. Positioning the antenna horizontally will provide better coverage above and below the hub.

Installing the wireless hub antenna extension accessory

An extension cable accessory (A80541) is available for the wireless hub's antenna. Using the extension the distance of the wireless hub's antenna can be extended a farther 5 m (16.4 ft).

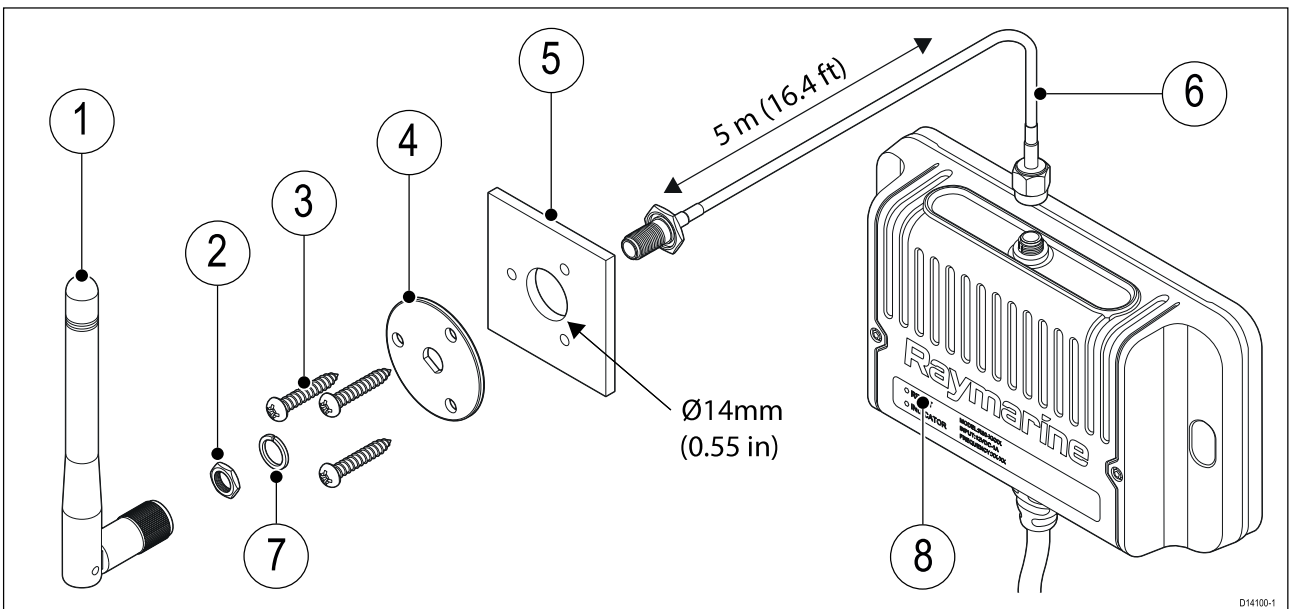

| | | | |
|---|-----------------------------------------------------------|---|---------------------------------------|
| 1 | Antenna (supplied with the hub) | 2 | Nut |
| 3 | M3x10 fixing screws x 3 | 4 | Mounting plate |
| 5 | Mounting surface (14 mm (0.55 in) diameter hole required) | 6 | 5 m (16.4 ft) antenna extension cable |
| 7 | Split washer | 8 | Wireless hub |

1. Check the selected location for the Mounting plate, a clear flat area is required.

2. Using a pencil, offer up the Mounting plate to the desired location and mark the location of the screw holes and the center hole on the mounting panel.
3. Drill holes for the mounting fixings using a drill with a suitable sized drill bit.
4. Drill the center hole using a 14 mm (0.55 in) drill/hole cutter.
5. Pull the connector end with the exposed thread through the center hole.
6. Place the mounting plate over the end of the connector.
7. Place the split washer and nut over the end of the connector and secure by hand tightening the nut.
8. Secure the mounting plate to the mounting surface using the supplied screws.
9. Screw the antenna supplied with your hub to the connector.
10. Connect the opposite end of the extension cable to the antenna connector located on the top of the wireless hub.

Mounting the charging holster for the wireless handset

Before mounting, ensure that:

- Your selected location meets the location requirements found in this document.
- You pay particular attention to the wireless location requirements.
- The product operates correctly at the desired location before mounting.
- The product does not interfere with nearby devices.

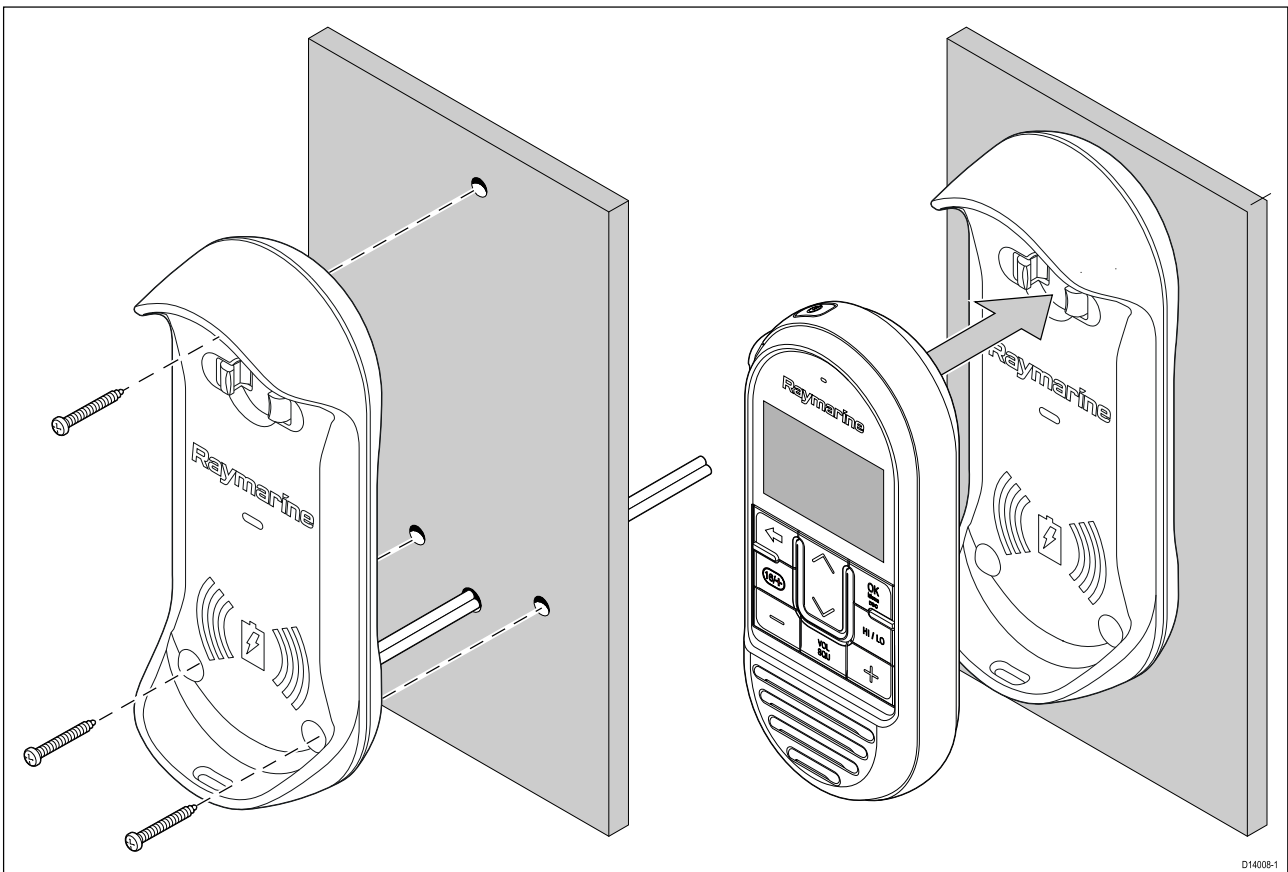

1. Using the supplied mounting template mark the location of the mounting holes and if required, the cable hole.
2. Drill the mounting holes using a suitable size drill bit.
3. If required, use a 6.5 mm (0.26 in) drill bit to drill a hole for the holster's power cable.
4. Hold the holster in place and secure using the screws provided.
5. Place the Handset into the holster, ensuring it clicks into position.

Chapter 4: Cables and connections

Chapter contents

- 4.1 General cabling guidance on page 64
- 4.2 Connections overview — Ray53 on page 66
- 4.3 Connections overview — Ray63 / Ray73 on page 67
- 4.4 Power connection on page 69
- 4.5 Fismic connection (Ray63 / Ray73 only) on page 74
- 4.6 Secondary handset station (Ray63 / Ray73 only) on page 76
- 4.7 SeaTalkng® / NMEA 2000 connection on page 77
- 4.8 NMEA 0183 connection on page 78
- 4.9 Connecting a VHF antenna on page 79
- 4.10 GNSS (GPS) antenna connection on page 80
- 4.11 Passive speaker connection on page 81
- 4.12 Wireless hub connection on page 82
- 4.13 Wireless handset charging holster – power connection on page 83
- 4.14 Wireless handset connections on page 84
- 4.15 Wireless speaker – power connection on page 85
- 4.16 Loud hailer connection (Ray73 only) on page 86

4.1 General cabling guidance

Cable types and length

It is important to use cables of the appropriate type and length

- Unless otherwise stated use only standard cables of the correct type, supplied by Raymarine.
- Ensure that any non-Raymarine cables are of the correct quality and gauge. For example, longer power cable runs may require larger wire gauges to minimize voltage drop along the run.

Routing cables

Cables must be routed correctly, to maximize performance and prolong cable life.

- Do NOT bend cables excessively. Wherever possible, ensure a minimum bend diameter (\emptyset) of 200 mm (7.87 in) / minimum bend radius (R) of 100 mm (3.94 in).

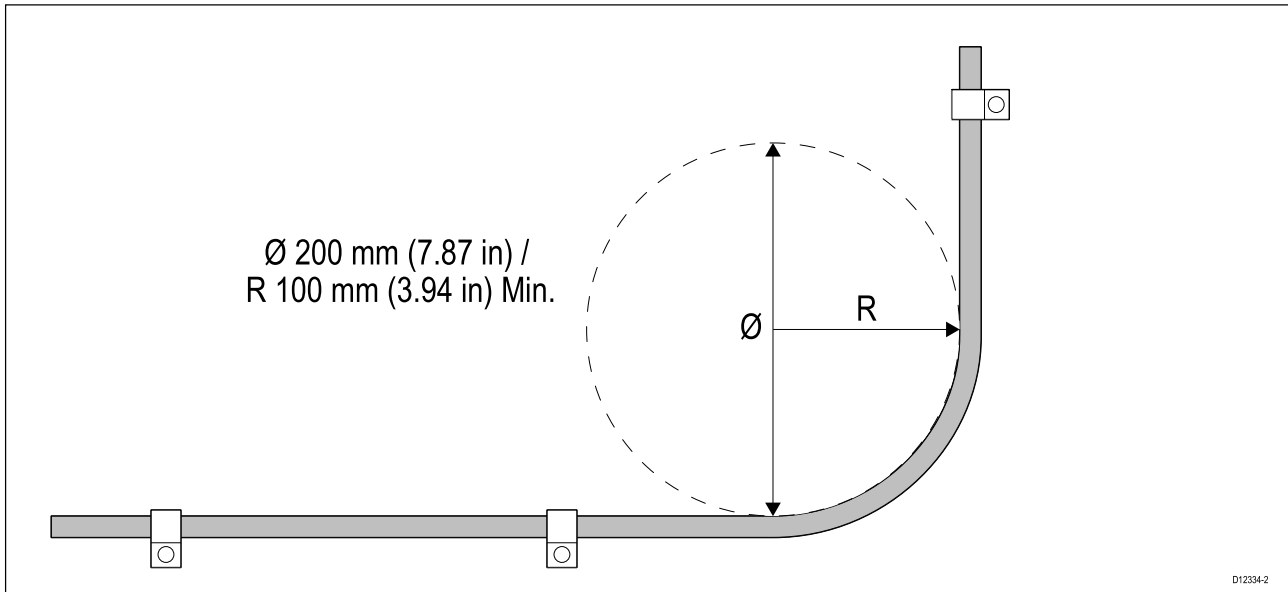

- Protect all cables from physical damage and exposure to heat. Use trunking or conduit where possible. Do NOT run cables through bilges or doorways, or close to moving or hot objects.
- Secure cables in place using cable clips or cable ties. Coil any extra cable and tie it out of the way.
- Where a cable passes through an exposed bulkhead or deckhead, use a suitable watertight feed-through.
- Do NOT run cables near to engines or fluorescent lights.

Always route data cables as far away as possible from:

- other equipment and cables,
- high current carrying AC and DC power lines,
- antennas.

Strain relief

Ensure adequate strain relief is provided. Protect connectors from strain and ensure they will not pull out under extreme sea conditions.

Circuit isolation

Appropriate circuit isolation is required for installations using both AC and DC current:

- Always use isolating transformers or a separate power-inverter to run PC's, processors, displays and other sensitive electronic instruments or devices.
- Always use an isolating transformer with Weather FAX audio cables.
- Always use an isolated power supply when using a 3rd party audio amplifier.
- Always use an RS232/NMEA converter with optical isolation on the signal lines.
- Always make sure that PC's or other sensitive electronic devices have a dedicated power circuit.

Cable shielding

Ensure that all cables are properly shielded and that the cable shielding is undamaged.

Connections to other equipment

Requirement for ferrites on non-Raymarine cables

If your Raymarine equipment is to be connected to other equipment using a cable not supplied by Raymarine, a suppression ferrite **MUST** always be attached to the cable near the Raymarine unit.

Dust caps

To prevent potential water ingress, connectors not in use should be protected using the supplied dust caps.

Bare end wire connections

Your product is supplied with bare end wire connections. You must ensure that ALL bare end wires are adequately protected from short circuit and water ingress.

Bare ended wire connections

It is recommended that bare ended wire connections are made by soldering or using crimp connectors and then protected by wrapping the connection in insulation tape.

Unused bare ended wires

Any unused bare ended wires should be folded back and wrapped in insulation tape.

4.2 Connections overview — Ray53

The following connections are available on the Ray53.

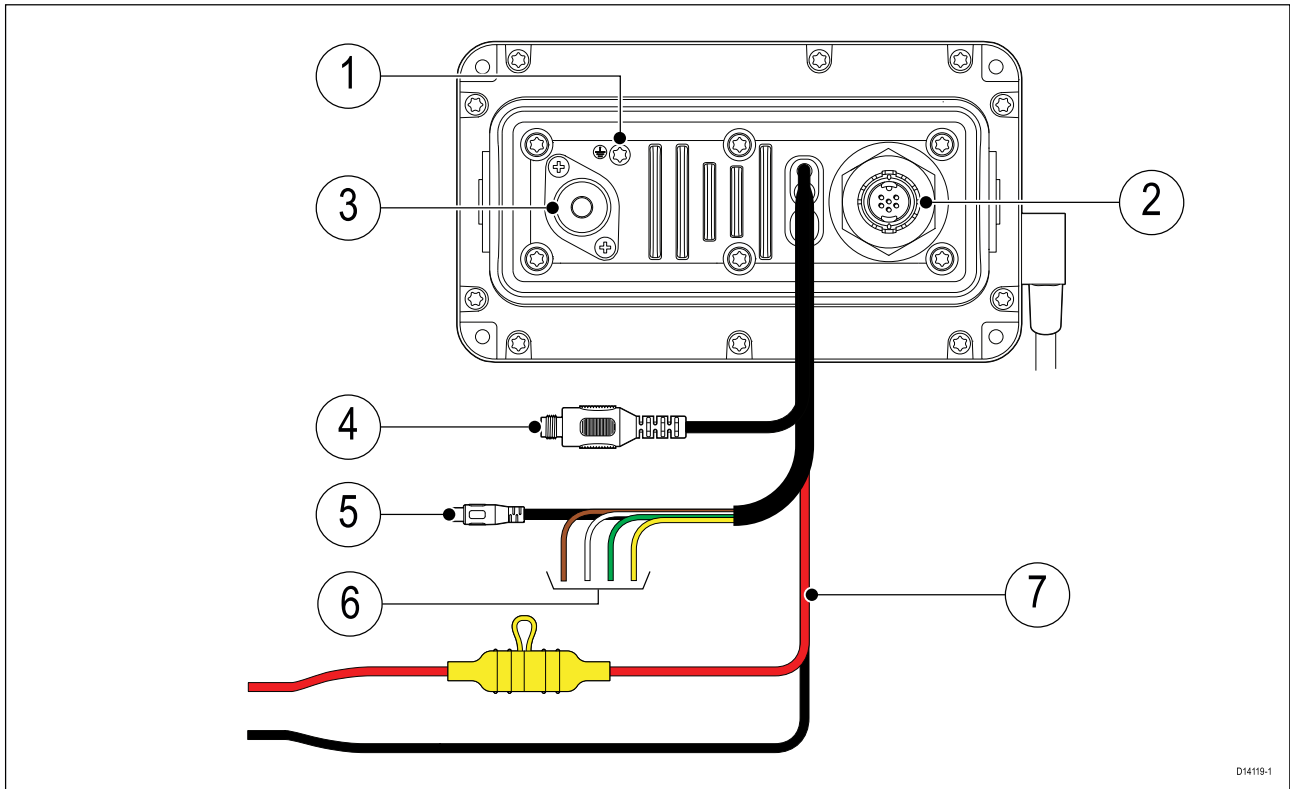

D14119-1

1. Grounding point — DO NOT USE!
2. SeaTalkng[®] connection.
3. SO239 VHF antenna connection.
4. TNC external GNSS (GPS) antenna connection.
5. RCA Audio connection.
6. NMEA 0183 connection.
7. Power supply connection.

4.3 Connections overview — Ray63 / Ray73

The following connections are available on the Ray63 and Ray73.

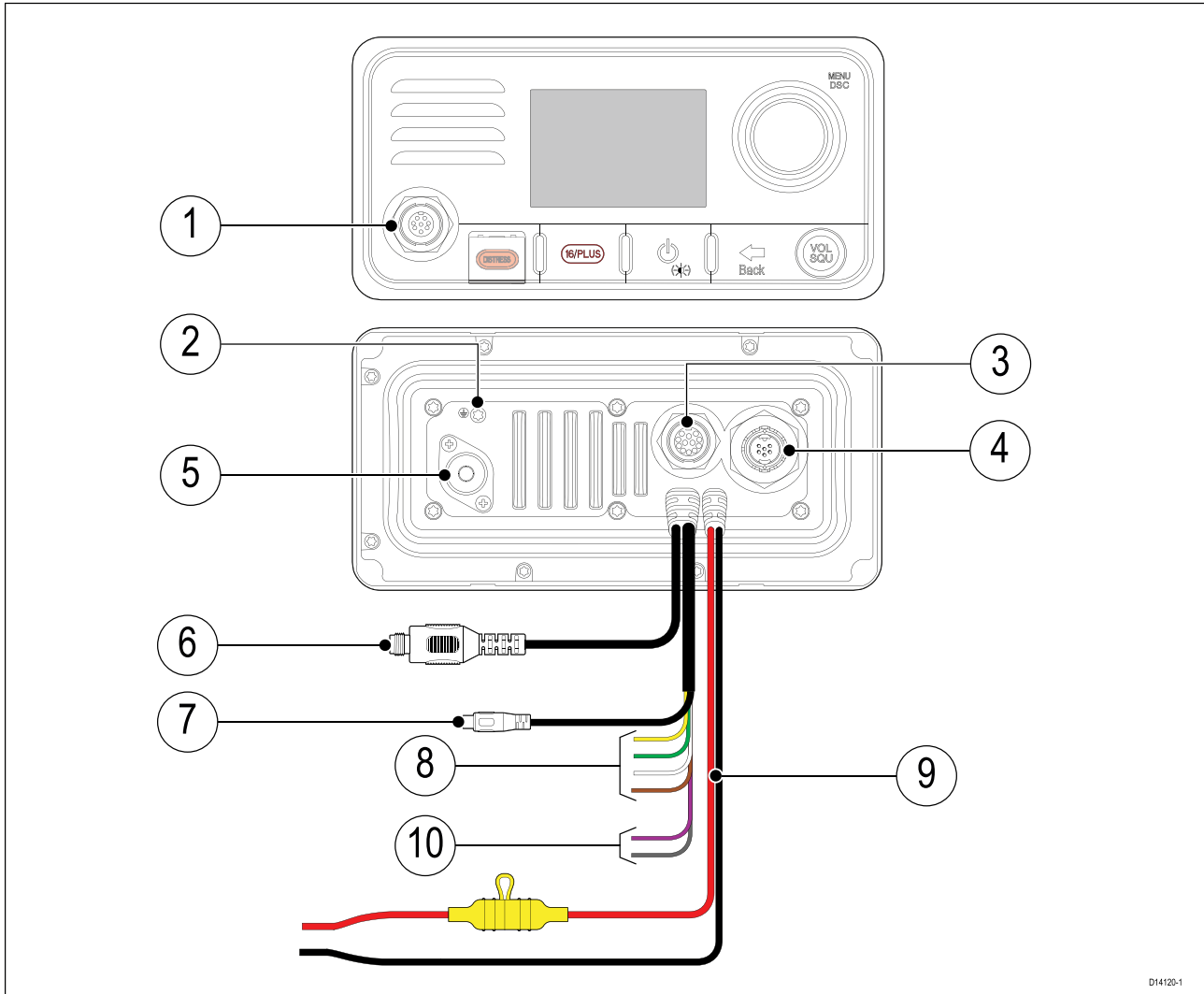

1. Primary station (8 pin) connection.
2. Grounding point — DO NOT USE!
3. Second station (12 pin) connection.
4. SeaTalkng® connection.
5. S0239 VHF antenna connection.
6. TNC GNSS (GPS) connection.
7. RCA Audio connection.
8. NMEA 0183 connection.
9. Power supply connection.
10. Loud hailer connection (Ray73 only).

Primary and secondary station connectors

The connectors below are used to connect the supplied Fistmic and / or the optional Wired (Raymic) handset to the Base station.

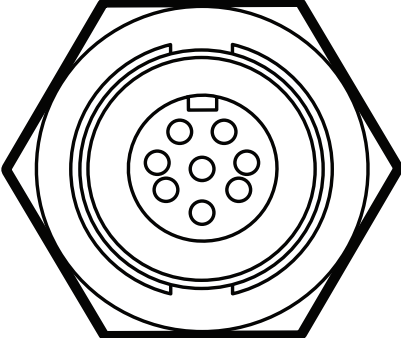
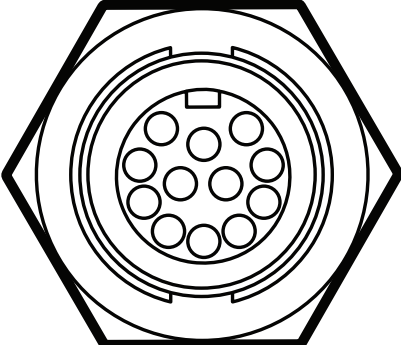
| Connector | Description | Connects to |
|------------------------------------------------------------------------------------|-------------------------------------------------------------|------------------------------------------------------------------------------------------------------------------------------------------------------------------------------------------------------------------------------------------------------------------------------------------------------------------|
|  | Primary station connector (8 pin front Fistmic connector) | <ul style="list-style-type: none"> • Fistmic (supplied) |
|  | Secondary station connector (12 pin rear handset connector) | <ul style="list-style-type: none"> • Wireless hub via adaptor (R70739) • Wired handset • Wired handset via Handset extension cables (A80291, A80292, A80290). • Fistmic via Fistmic adaptor cable (A80296) • Wired handset via Handset adaptor cable (A80297) |

4.4 Power connection

The power supply should be connected as shown below:

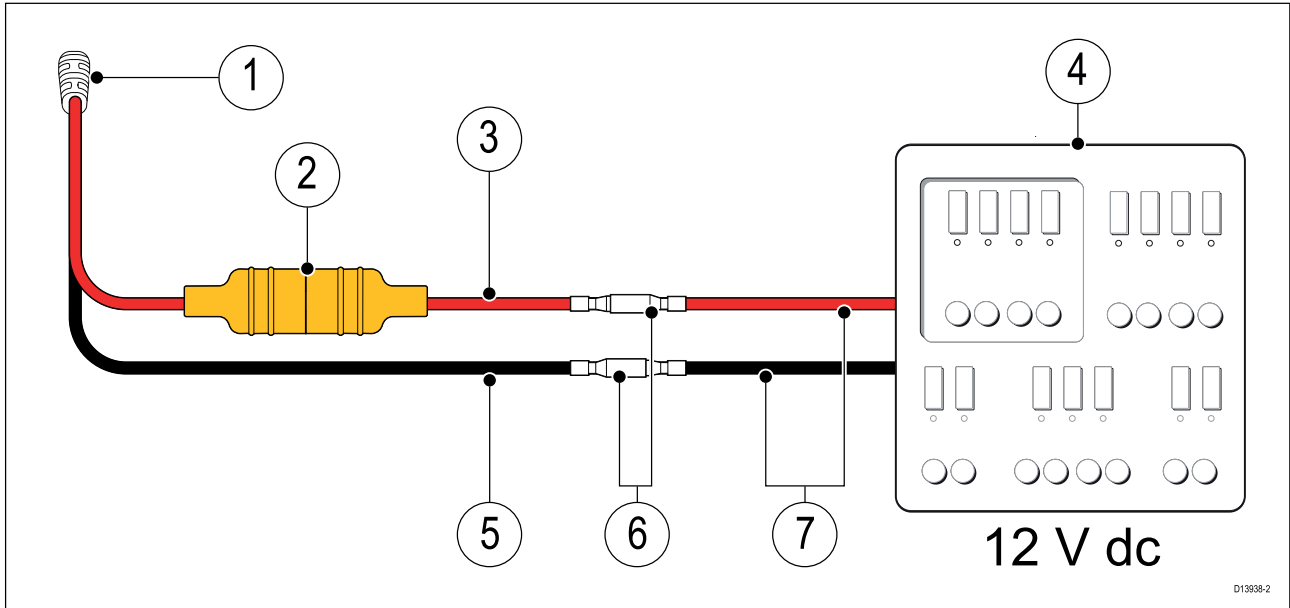

1. Radio's fitted power cable.
2. In-line fuse.
3. Power supply positive (+) Red wire
4. 12 V dc power source (i.e.: Distribution panel).
5. Power supply negative (-) Black wire.
6. Suitable waterproof connection (Radio is supplied with bullet crimps on power supply wires.)
7. If, required you can extend the power cable supplied with your radio, using suitably rated cabling.



Warning: 12 Volt dc only

This product must only be connected to a **12 volt dc** power source.



Warning: Positive ground systems

Do not connect this unit to a system which has positive grounding.

In-line fuse and thermal breaker ratings

The following in-line fuse and thermal breaker ratings apply to your product:

| In-line fuse rating | Thermal breaker rating |
|---------------------|-------------------------------------|
| 10 A | 7 A (if only connecting one device) |

Note:

- The suitable fuse rating for the thermal breaker is dependent on the number of devices you are connecting. If in doubt consult an authorized **Raymarine**® dealer.
- Your product's power cable may have a fitted in-line fuse. If not, add an in-line fuse to the positive wire of your product's power connection.

Grounding

This product is grounded through the 0 V dc negative wire on the power cable and does not require a drain (shield) to be connected to the base station's ground terminal.



Warning: Chassis grounding

Do NOT ground this product using the chassis ground terminal.

Grounding this product to a vessel's RF ground may cause galvanic corrosion.

Power distribution

Recommendations and best practice.

- The product is supplied with a power cable, either as a separate item or a captive cable permanently attached to the product. Only use the power cable supplied with the product. Do NOT use a power cable designed for, or supplied with, a different product.
- Refer to the *Power connection* section for more information on how to identify the wires in your product's power cable, and where to connect them.
- See below for more information on implementation for some common power distribution scenarios.

Important:

When planning and wiring, take into consideration other products in your system, some of which (e.g. sonar modules) may place large power demand peaks on the vessel's electrical system, which may impact the voltage available to other products during the peaks.

Note:

The information provided below is for guidance only, to help protect your product. It covers common vessel power arrangements, but does NOT cover every scenario. If you are unsure how to provide the correct level of protection, please consult an authorized Raymarine dealer or a suitably qualified professional marine electrician.

Implementation — direct connection to battery

- The power cable supplied with your product may be connected directly to the vessel's battery, via a suitably rated fuse or breaker.
- The power cable supplied with your product may NOT include a separate drain wire. If this is the case, only the power cable's red and black wires need to be connected.
- If the supplied power cable is NOT fitted with an inline fuse, you MUST fit a suitably rated fuse or breaker between the red wire and the battery's positive terminal.
- Refer to the inline fuse ratings provided in the product's documentation.
- If you need to extend the length of the power cable supplied with your product, ensure you observe the dedicated *Power cable extensions* advice provided in the product's documentation.

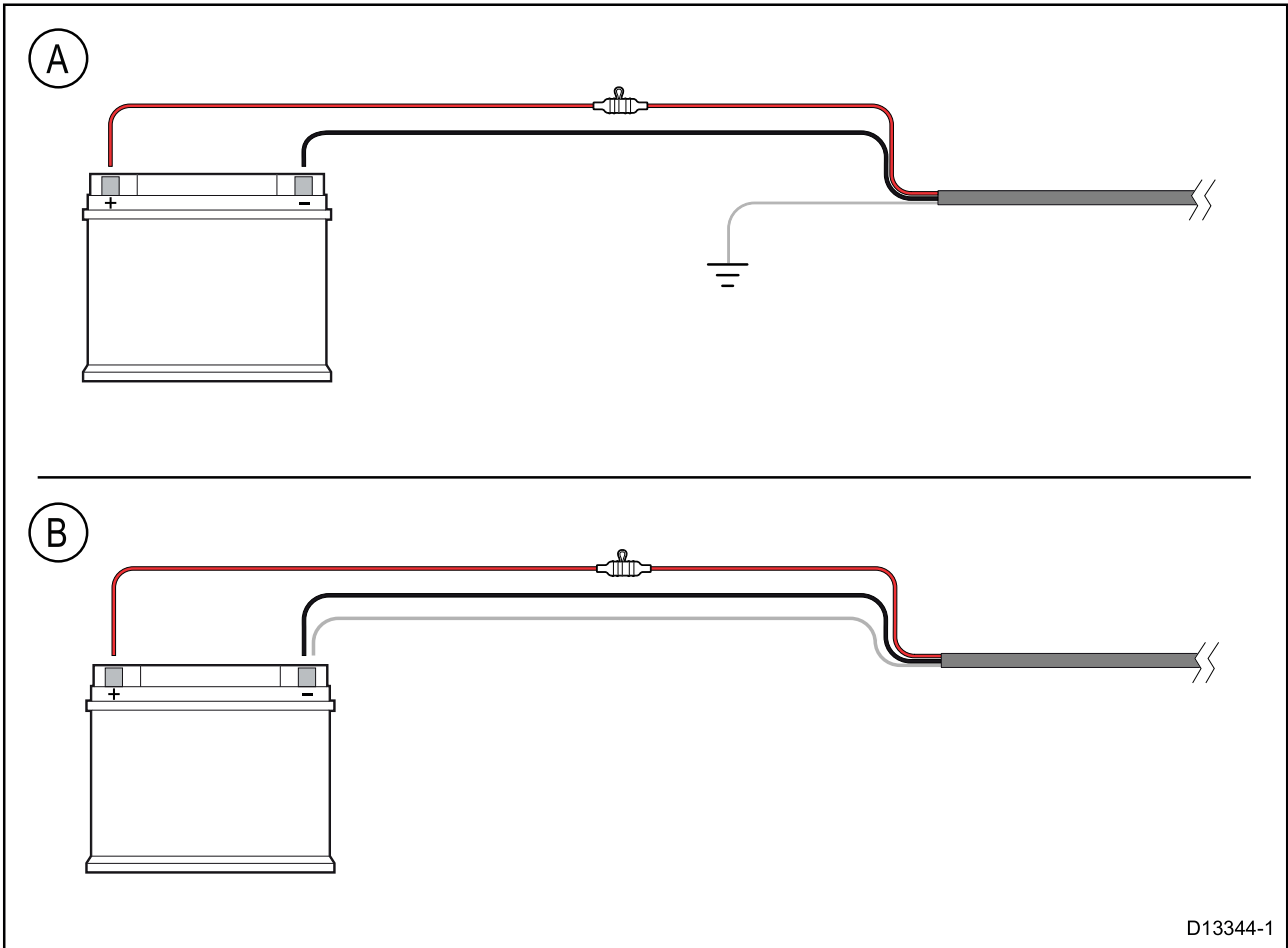

D13344-1

| | |
|---|----------------------------------------------------------------------------------------------------------------------------------------------------------------------------------------------------------------------------------------------------|
| A | Battery connection scenario A: suitable for a vessel with a common RF ground point. In this scenario, if your product's power cable is supplied with a separate drain wire then it should be connected to the vessel's common ground point. |
| B | Battery connection scenario B: suitable for a vessel without a common grounding point. In this case, if your product's power cable is supplied with a separate drain wire then it should be connected directly to the battery's negative terminal. |

Implementation – connection to distribution panel

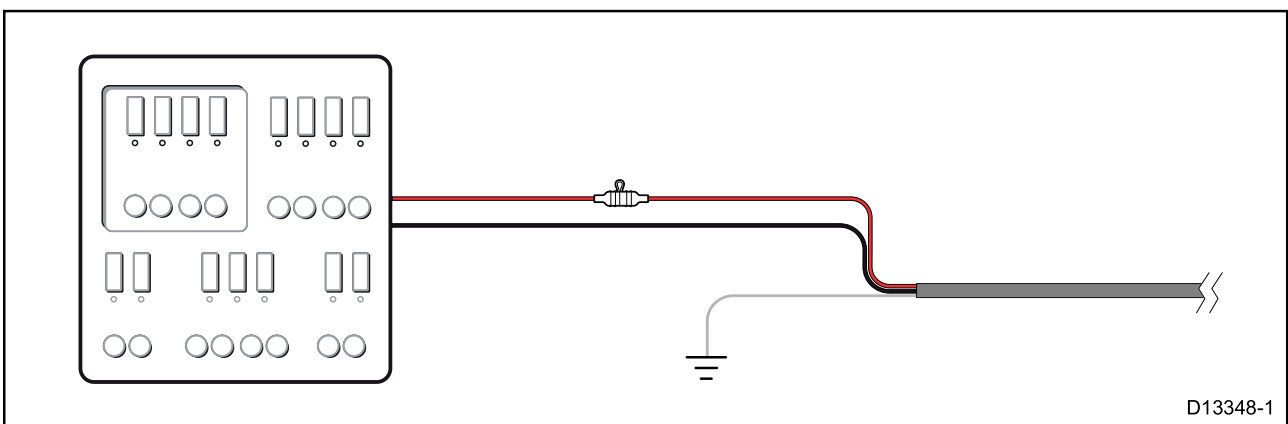

D13348-1

- Alternatively, the supplied power cable may be connected to a suitable breaker or switch on the vessel's distribution panel or factory-fitted power distribution point.
- The distribution point should be fed from the vessel's primary power source by 8 AWG (8.36 mm²) cable.
- Ideally, all equipment should be wired to individual suitably-rated thermal breakers or fuses, with appropriate circuit protection. Where this is not possible and more than 1 item of equipment shares a breaker, use individual in-line fuses for each power circuit to provide the necessary protection.

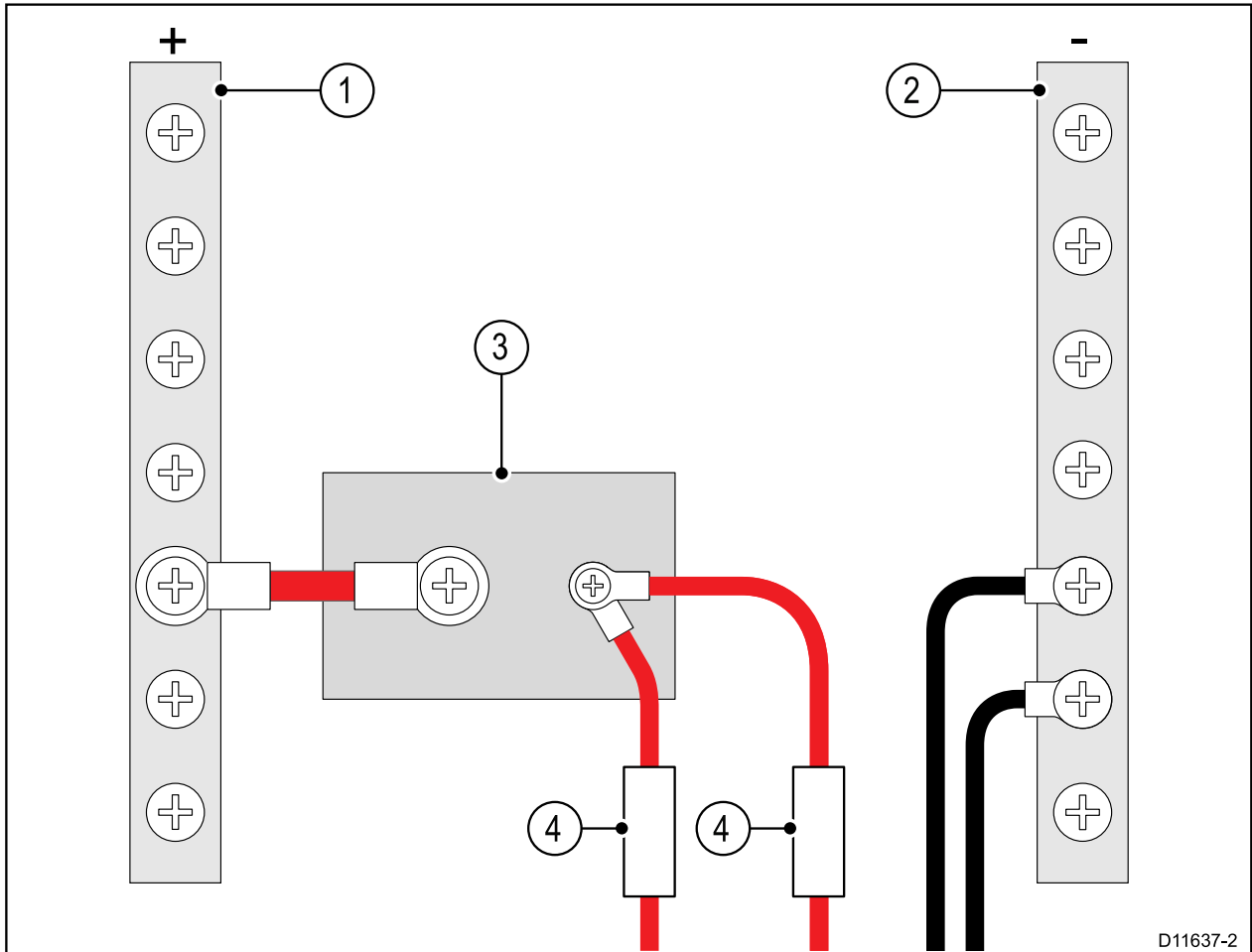

| | |
|---|------------------|
| 1 | Positive (+) bar |
| 2 | Negative (-) bar |
| 3 | Circuit breaker |
| 4 | Fuse |

- In all cases, observe the recommended breaker / fuse ratings provided in the product's documentation.

Important:

Be aware that the suitable fuse rating for the thermal breaker or fuse is dependent on the number of devices you are connecting.

Power cable extension

If you need to extend the length of the power cable supplied with your product, ensure you observe the following advice:

- The power cable for each unit in your system should be run as a separate, single length of 2-wire cable from the unit to the vessel's battery or distribution panel.
- For power cable extensions, a **minimum** wire gauge of 16 AWG (1.31 mm²) is recommended. For cable runs longer than 15 meters, you may need to consider a thicker wire gauge (e.g. 14 AWG (2.08 mm²), or 12 AWG (3.31 mm²)).
- An important requirement for all lengths of power cable (including any extension) is to ensure that there is a continuous **minimum** voltage at the product's power connector of 10.8 V dc, with a fully flat battery at 11 V dc.

Important: Be aware that some products in your system (such as sonar modules) can create voltage peaks at certain times, which may impact the voltage available to other products during the peaks.

Grounding

Ensure that you observe any separate grounding advice provided in the product's documentation.

More information

It is recommended that best practice is observed in all vessel electrical installations, as detailed in the following standards:

- BMEA Code of Practice for Electrical and Electronic Installations in Boats
- NMEA 0400 Installation Standard
- ABYC E-11 AC & DC Electrical Systems on Boats
- ABYC A-31 Battery chargers and Inverters
- ABYC TE-4 Lightning Protection

4.5 Fistmic connection (Ray63 / Ray73 only)

Front connection

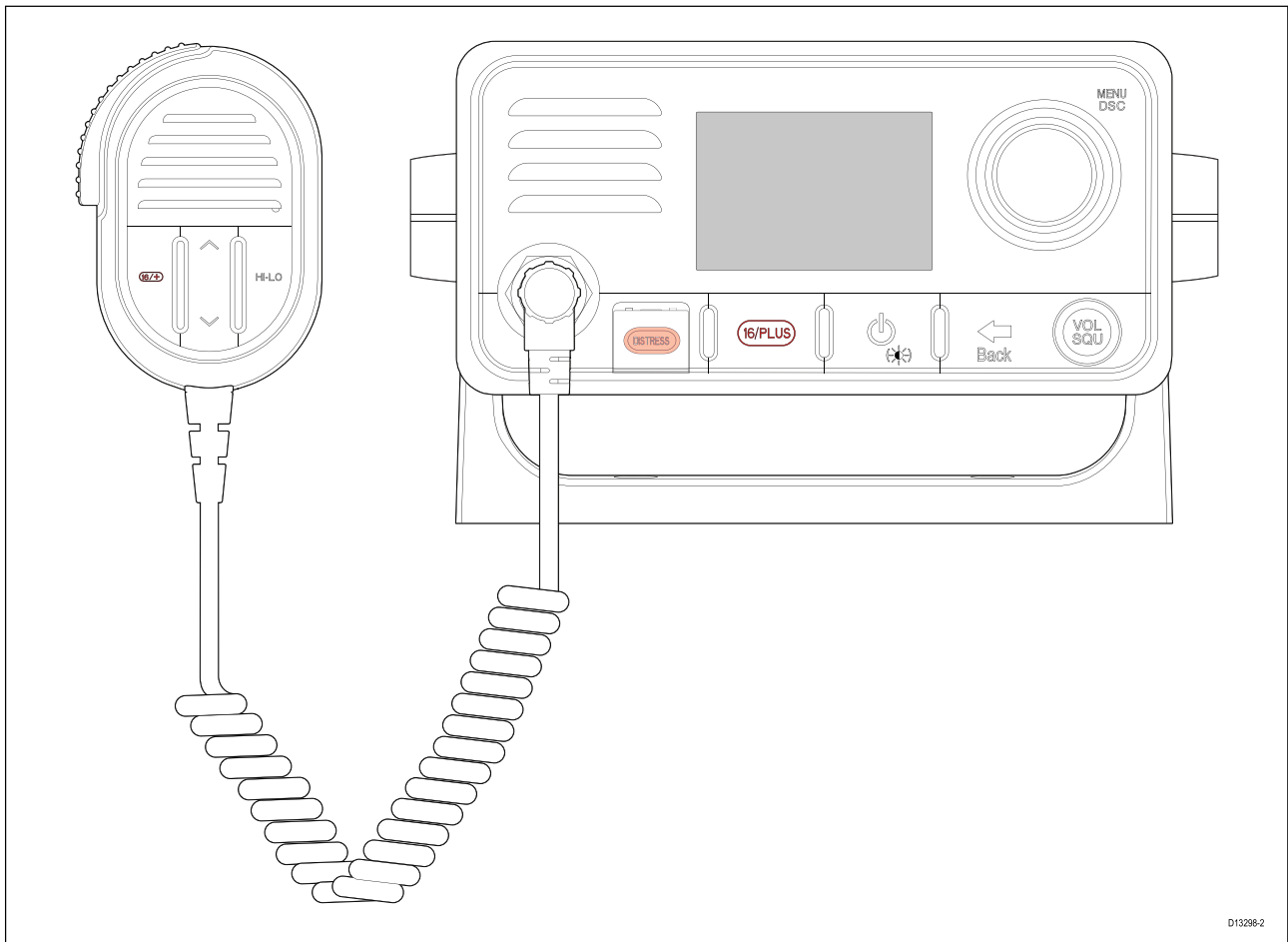

The Fistmic can be connected directly to the front connector on your Radio.

Rear connection

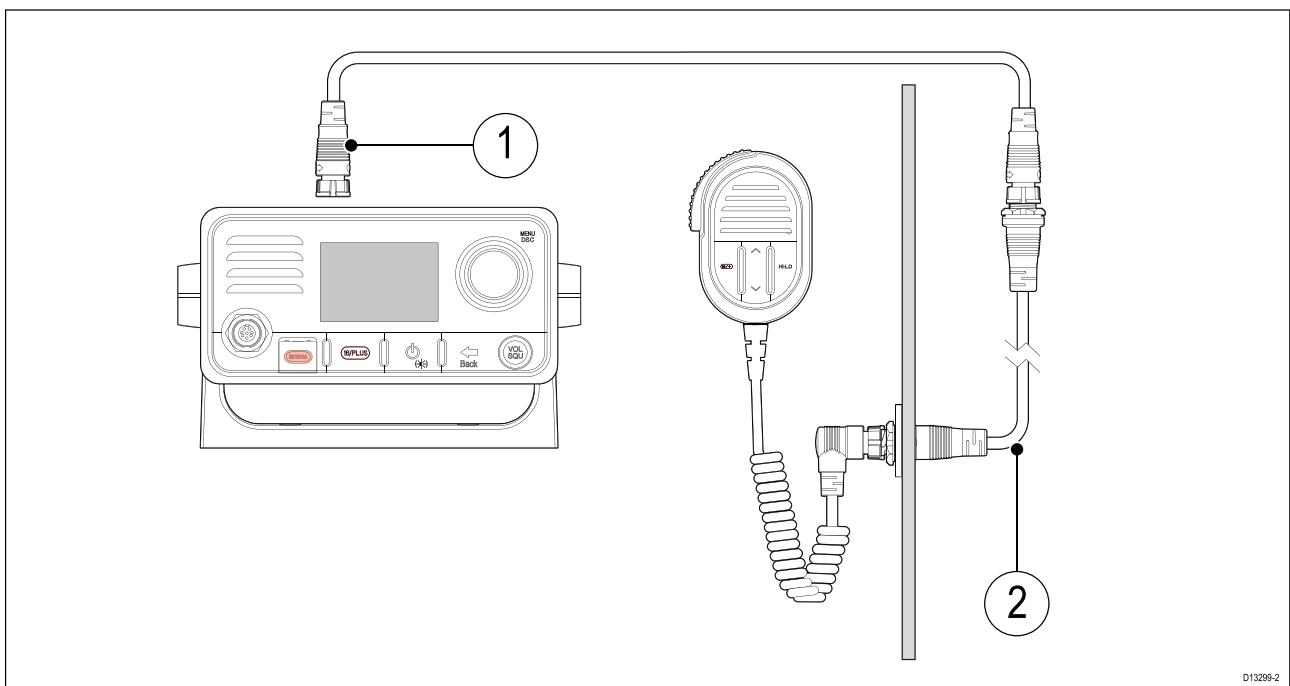

1. Handset extension cable (A80291)
2. Fistmic adaptor cable (A80296)

The Fistmic can also be connected to the Rear station connection using the appropriate adaptor cables.

The Fismic must NOT be used to create a second station, as the operator will not have access to all Radio functions or the information displayed on the Radio's LCD screen.

4.6 Secondary handset station (Ray63 / Ray73 only)

The Raymic handset accessory can be connected to the Secondary station connector located on the rear of the radio, this will create a second fully functional station.

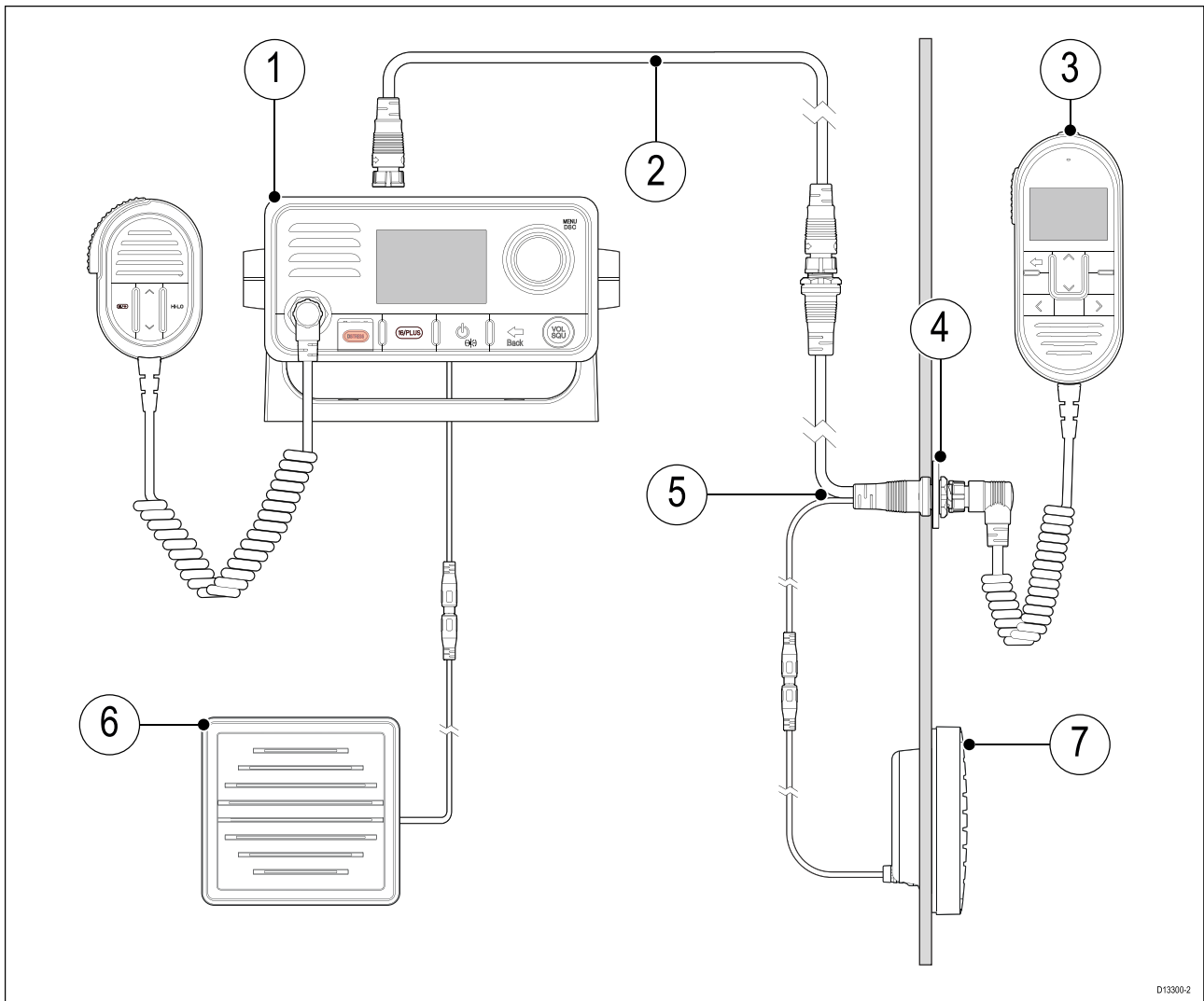

1. Primary station (Radio base station)
2. Handset extension cable (A80290, A80291 or A80292)
3. Secondary station handset (A80289)
4. Panel mount fixings kit (R70438)
5. Handset adaptor cable with RCA audio (A80297)
6. Primary station passive speaker (A80542)
7. Secondary station passive speaker (A80542)

The Fistmic must NOT be used to create a second station, as the operator will not have access to all Radio functions or the information displayed on the Radio's LCD screen.

Wired handset extension cables

Handset station cabling can be extended using approved extension cables.

The maximum length of cable from the Handset to the Base station should not exceed 50 m (164 ft)

Connecting handsets and cables

Follow the steps below to connect handsets and extension cables together.

1. If fitted, unscrew and remove the dust cap from the relevant connector.
2. Ensure the cable connectors are correctly orientated, before insertion.
3. Ensure connectors are fully inserted, before locking..
4. Tighten locking collars by Rotating clockwise.

4.7 SeaTalkng® / NMEA 2000 connection

Your product can transmit and receive data to and from devices connected on SeaTalkng® or NMEA 2000 CAN bus networks. Connection is established using the SeaTalkng® connector located on the rear of the unit.

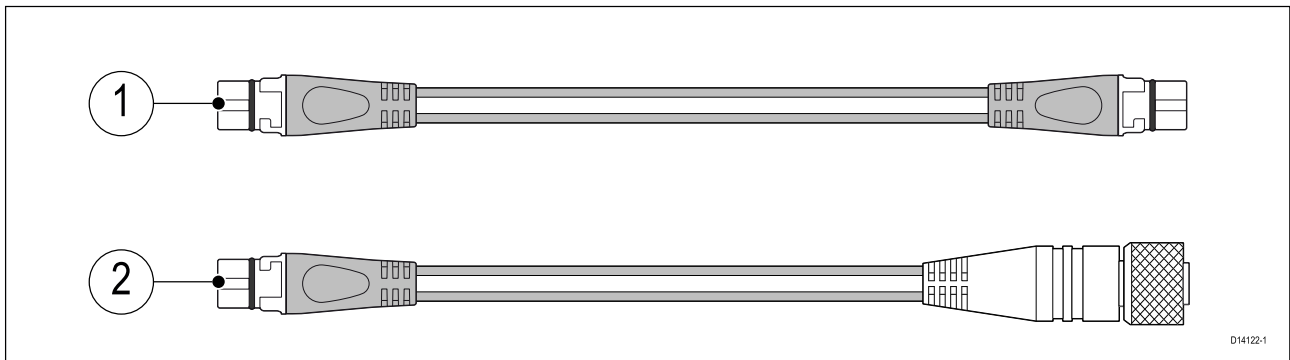

1. Use the supplied SeaTalkng® spur cable to connect your product to your SeaTalkng® network.
2. You can also use a DeviceNet to SeaTalkng® adaptor cable (not supplied) to connect your product to an available spur on a NMEA 2000 network.

Note:

1. The product must be connected to a correctly terminated backbone.
2. You cannot connect your product directly to a MFD.
3. Refer to the instructions supplied with your SeaTalkng® / NMEA 2000 device for details on creating a backbone.

Connecting SeaTalkng® cables

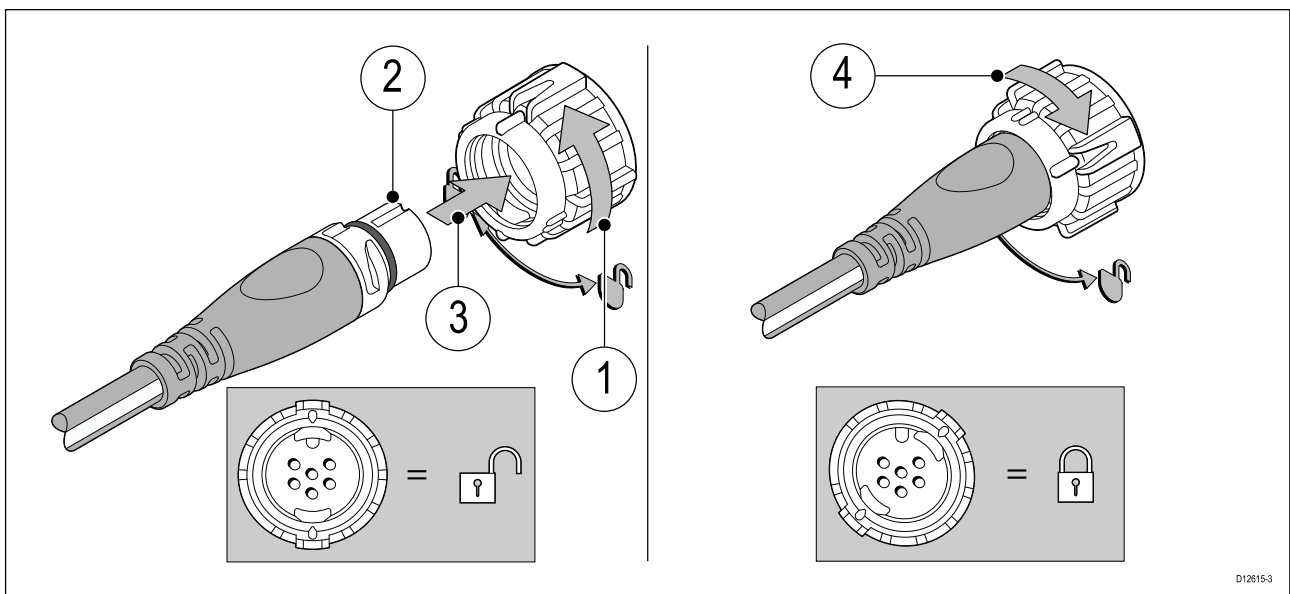

1. Rotate the locking collar so it is in the unlocked position.
2. Ensure the cable's connector is correctly oriented.
3. Fully insert the cable connector.
4. Rotate locking collar clockwise (2 clicks) until it is in the locked position.

4.8 NMEA 0183 connection

The NMEA 0183 wires can be used to connect the unit to a NMEA 0183 GNSS (GPS) receiver or MFD.

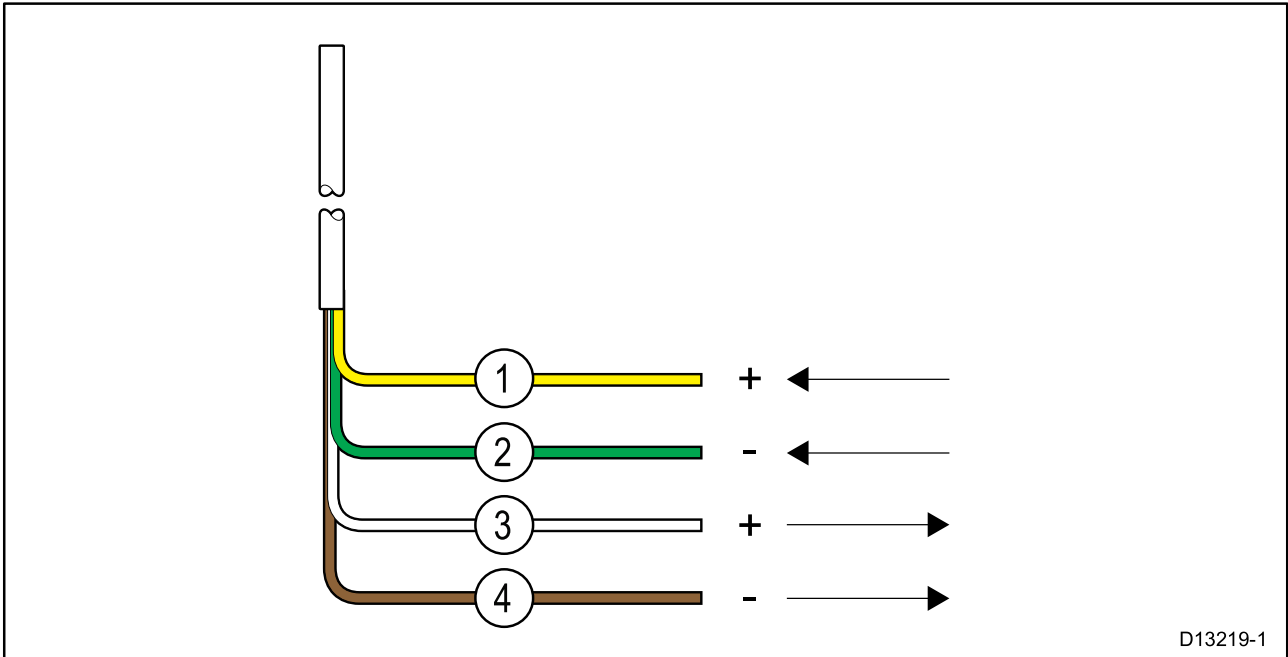

1. Yellow = Receive positive (+) wire
2. Green = Receive negative (-) wire
3. White = Transmit positive (+) wire
4. Brown = Transmit negative (-) wire

The NMEA wires should be connected to a compatible device as shown in the table below:

| NMEA 0183 wires | | NMEA 0183 device |
|-----------------------|----|-----------------------|
| Receive positive (+) | to | Transmit positive (+) |
| Receive negative (-) | to | Transmit negative (-) |
| Transmit positive (+) | to | Receive positive (+) |
| Transmit negative (-) | to | Receive negative (-) |

4.9 Connecting a VHF antenna

The radio must be connected to a suitable VHF antenna (not supplied). The antenna connection must be protected so it cannot come into contact with any bare metal (which may be grounded). A protective boot is supplied that can be used to ensure isolation of the antenna connection.

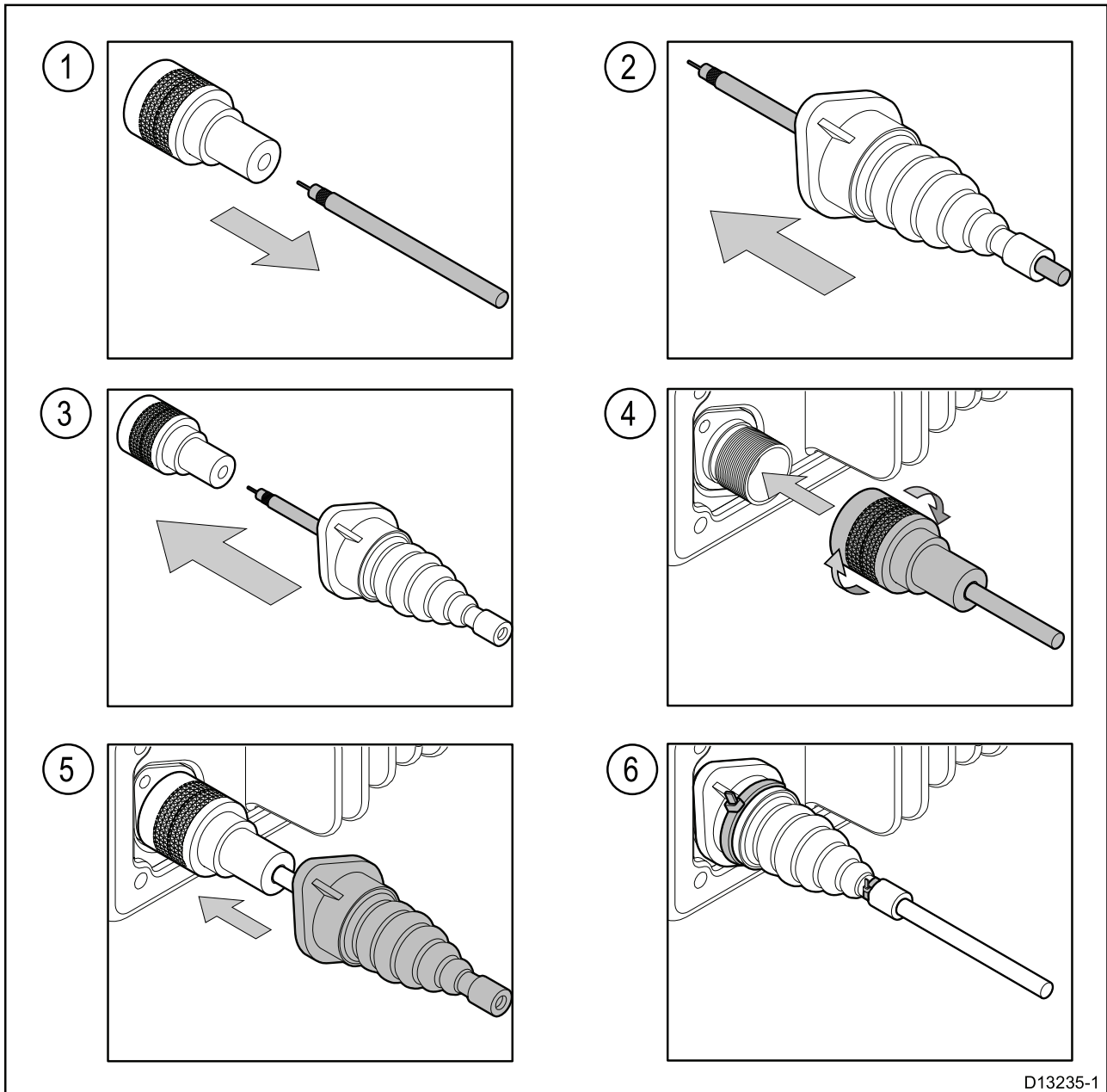

1. Disconnect your antenna cable from the connector.
2. Push the antenna cable through the supplied protective boot.
3. Re-connect the antenna cable to the connector.
4. Plug the antenna connector into the product's antenna connection and secure by tightening the locking collar.
5. Push the protective boot over the connection.
6. Secure the protective boot using the supplied cable ties.

If the antenna connector cannot be removed then another suitable means of protection must be used, such as insulation tape.

4.10 GNSS (GPS) antenna connection

You can improve the performance of your radio's built-in GNSS (GPS) receiver using an external antenna.

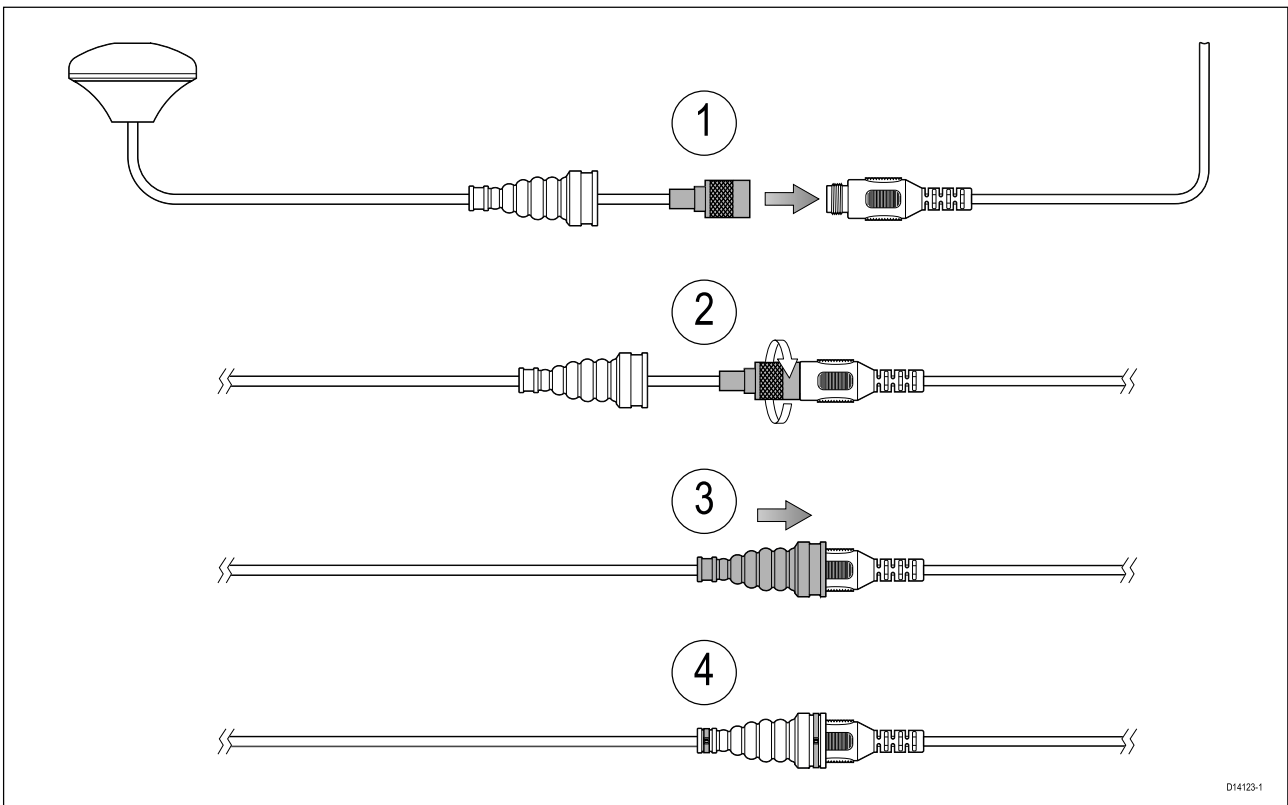

Follow the steps below to connect the external antenna:

1. Remove the dust cap from the external antenna connector on your radio. Ensuring correct connector orientation, fully insert the external antenna connector into the GA150's connector.
2. Tighten the antenna connector's locking collar by rotating the GA150's connector clockwise until tight.
3. Push the protective boot into position over both connectors.
4. Secure the protective boot using a cable tie on each end.

4.11 Passive speaker connection

A passive speaker (A80542) can be connected using the RCA lead on the radio or on the handset adaptor cable.

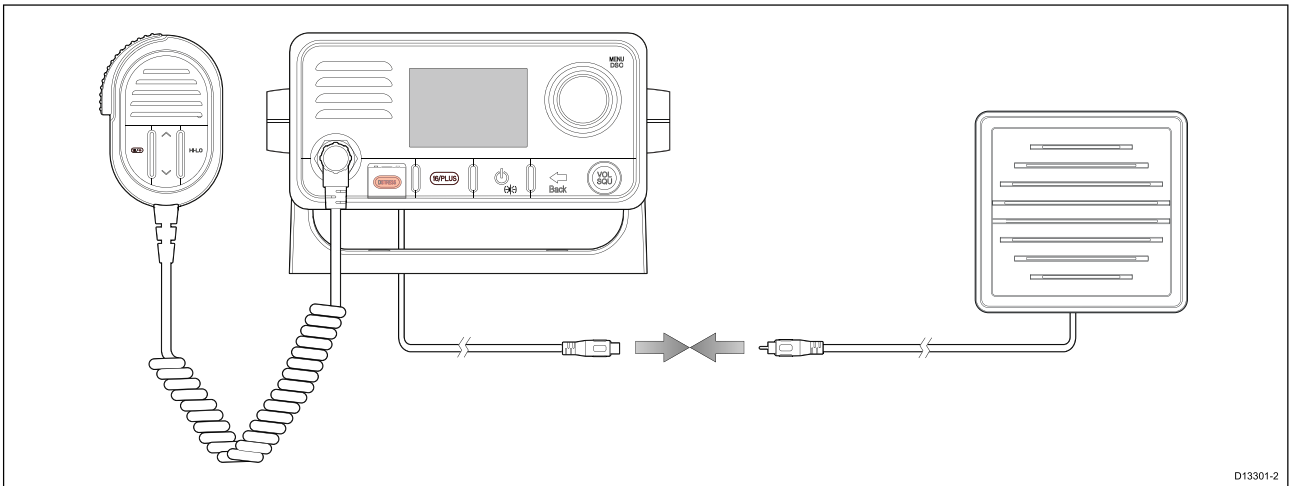

4.12 Wireless hub connection

The Wireless hub connects to the second station connector on the rear of the Ray63 / Ray73 radios using the Wireless hub adaptor. The Wireless hub allows connection of wireless handset stations.

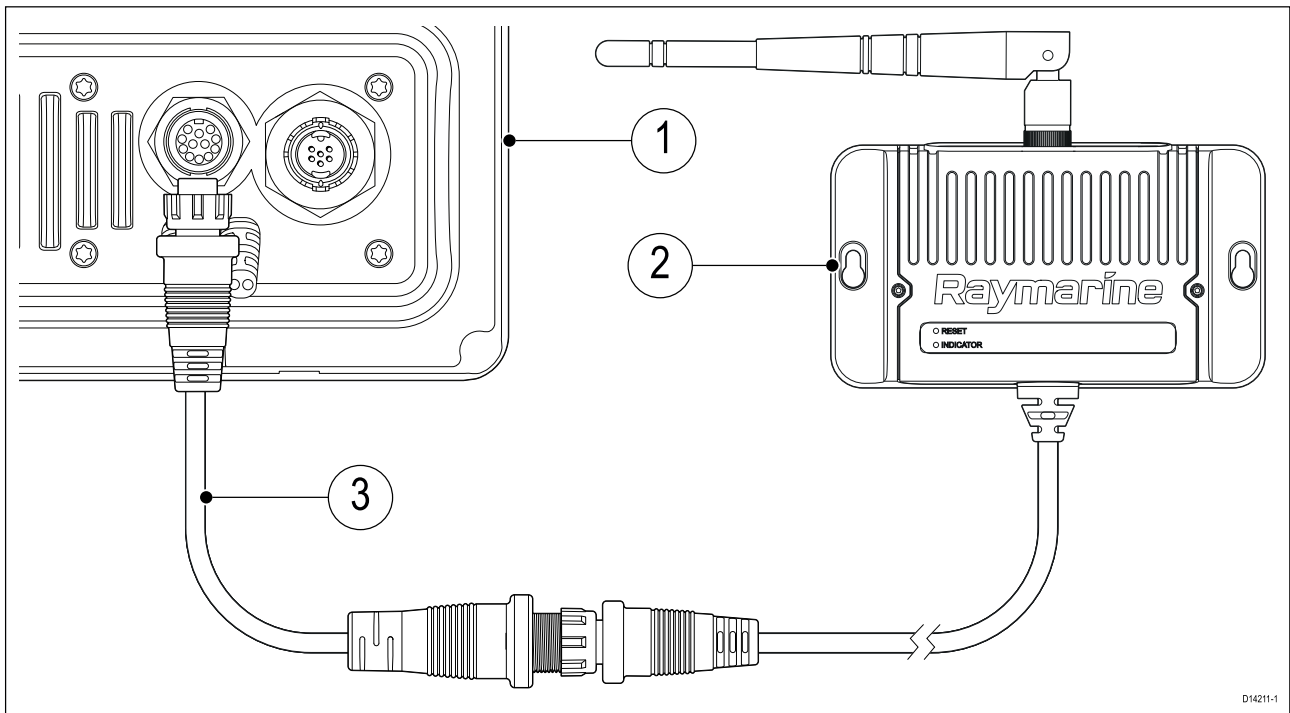

1. Ray63 / Ray73 VHF radio.
2. Wireless hub A80540.
3. Wireless hub adaptor (R70739).

4.13 Wireless handset charging holster – power connection

To enable inductive charging of the wireless handset, the holster requires a 12 V dc power supply. The power cables should be connected via a distribution panel or, if required directly to a battery.

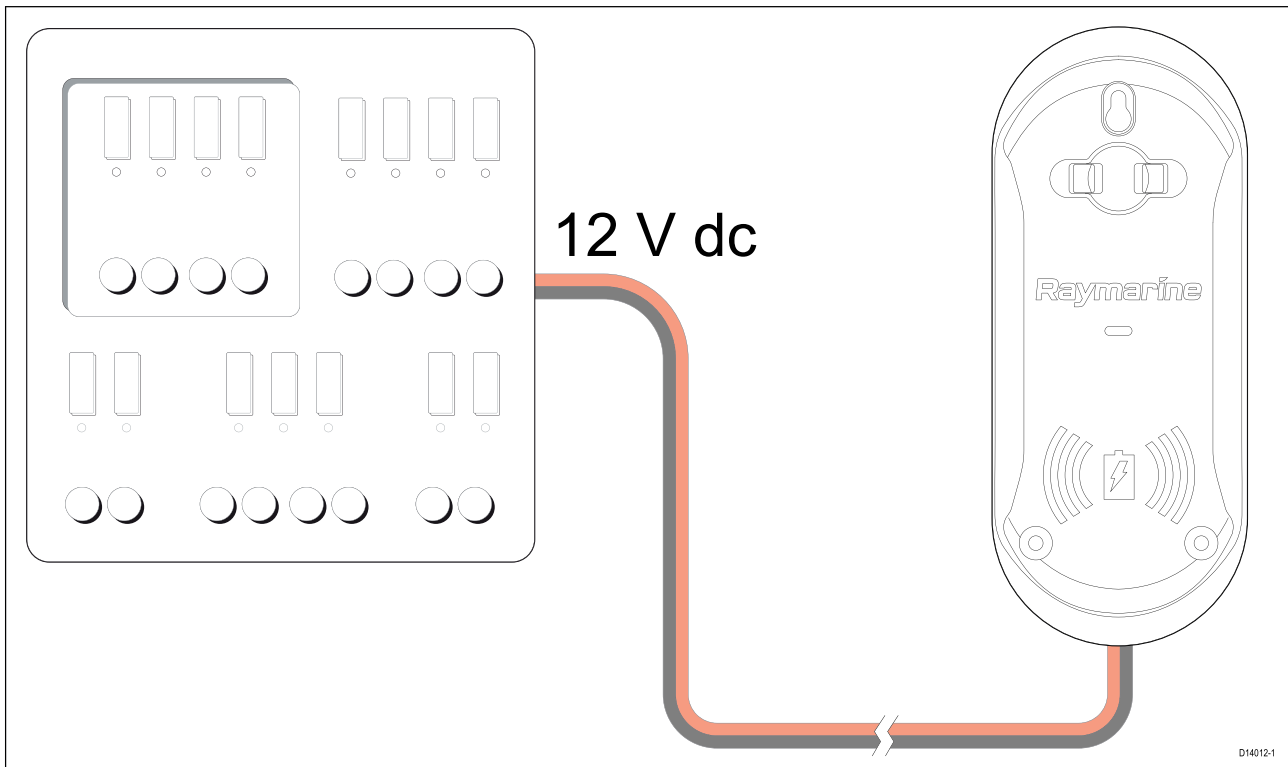

Refer to the [Power distribution](#) section for guidance on connecting to a power supply.

In-line fuse and thermal breaker ratings

The wireless speaker is internally fused, however it is recommended that you fit an inline fuse on the positive wire of your product's power cable or connect using a thermal breaker.

| In-line fuse rating | Thermal breaker rating |
|---------------------|---------------------------|
| 2 A | 2 A (refer to note below) |

Note:

- The suitable fuse rating for the thermal breaker is dependent on the number of devices you are connecting. If in doubt consult an authorized Raymarine® dealer.

4.14 Wireless handset connections

The Wireless handset connects wirelessly to the Wireless hub, and the Wireless speaker connects wirelessly to the Wireless handset.

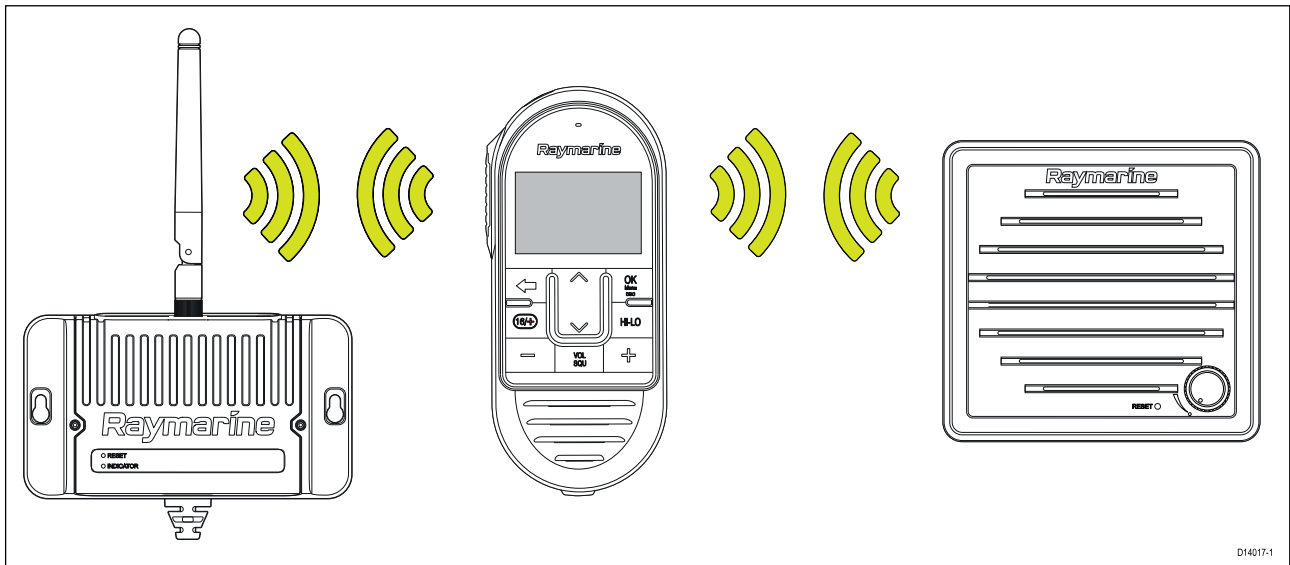

Up to 2 Wireless handsets can be connected to the Wireless hub. Refer to [6.2 Connecting a wireless handset to the hub](#) for the connection procedure.

One Wireless speaker can be connected to each Wireless handset. Refer to [6.3 Connecting the wireless speaker to the Wireless handset](#) for the connection procedure.

4.15 Wireless speaker – power connection

The wireless speaker is an active speaker that requires a 12 V dc power supply. The power cables should be connected via a distribution panel or, if required directly to a battery.

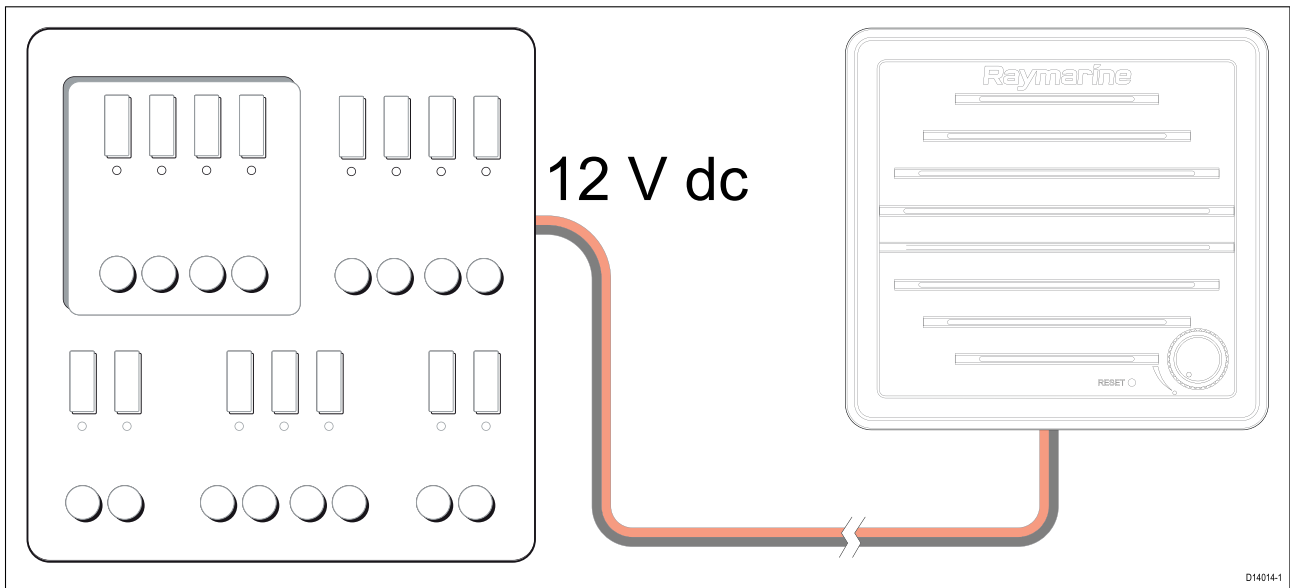

Refer to the [Power distribution](#) section for guidance on connecting to a power supply.

In-line fuse and thermal breaker ratings

The wireless speaker is internally fused, however it is recommended that you fit an inline fuse on the positive wire of your product's power cable or connect using a thermal breaker.

| In-line fuse rating | Thermal breaker rating |
|---------------------|---------------------------|
| 2 A | 2 A (refer to note below) |

Note:

- The suitable fuse rating for the thermal breaker is dependent on the number of devices you are connecting. If in doubt consult an authorized Raymarine® dealer.

4.16 Loud hailer connection (Ray73 only)

A Loud hailer (M95435) can be connected to the radio using the loud hailer wires.

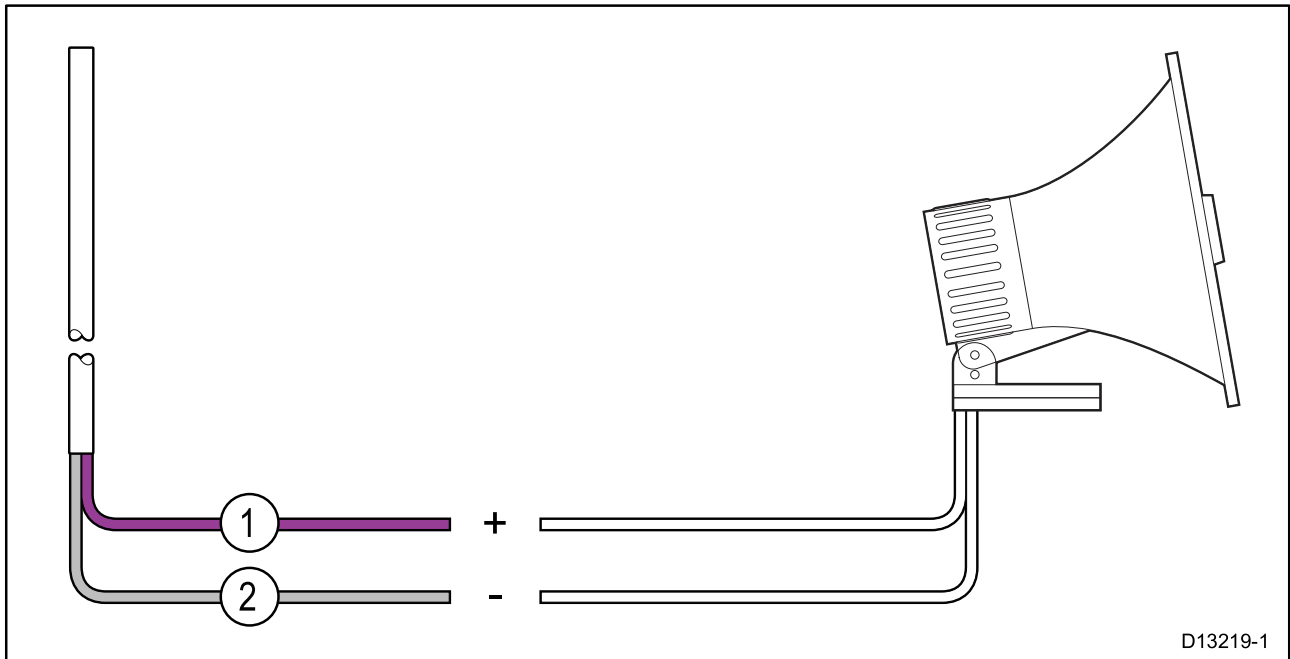

| | |
|---|-----------------------------------|
| 1 | Positive (+) hailer wire (Purple) |
| 2 | Negative (-) hailer wire (Gray) |

Chapter 5: Getting started

Chapter contents

- 5.1 Controls and interface on page 88
- 5.2 Handset controls on page 90
- 5.3 Powering the unit on on page 91
- 5.4 Powering the unit off on page 93
- 5.5 Homescreen overview on page 94
- 5.6 Shortcut list on page 100
- 5.7 Shared Brightness on page 101
- 5.8 Initial startup on page 103
- 5.9 Accessing the menu on page 104
- 5.10 Selecting a language on page 105
- 5.11 Switching on the AIS receiver on page 106
- 5.12 Selecting a network type on page 107
- 5.13 Entering your MMSI number on page 108
- 5.14 Entering your ATIS ID on page 110
- 5.15 Changing the radio region on page 112
- 5.16 Switching between high and low transmit power on page 113
- 5.17 GNSS (GPS) set up on page 114
- 5.18 Station priority (Ray63 and Ray73 only) on page 116

5.1 Controls and interface

The controls and interface available are as follows:

Base station

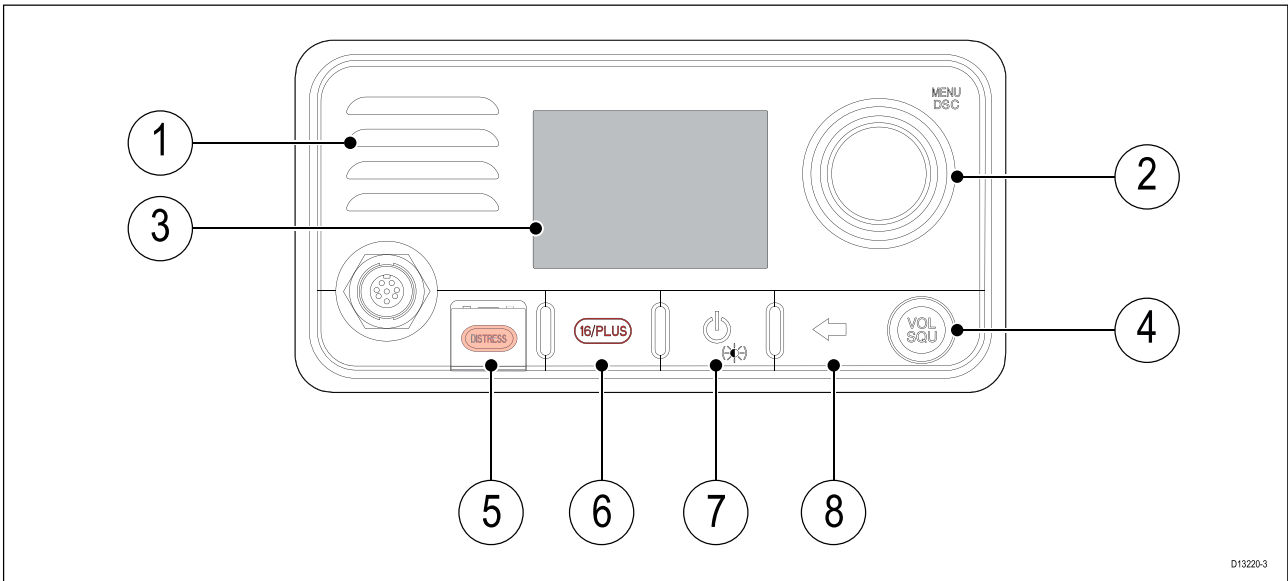

1. **Built-in speaker**
2. **Rotary knob** with center **OK** push button — Press knob in to access menu and DSC functions and to confirm selections. Turn rotary clockwise or anti-clockwise to move up and down through menu items or to change channel from the Homescreen.
3. **LCD**
4. **VOL/SQ** — Turn knob to adjust volume or squelch up and down. Press center button to switch between volume and squelch control.
5. **DISTRESS** — Push up the spring loaded cover and press this button to make a DSC distress call.
6. **16 / +** — When powered on press to switch between priority channels.
7. **Power** — Press to power the unit on. Press and hold for 3 seconds to power the unit off. Momentary press to access the shortcut list.
8. **Back** — Move back through menu options.

Fistmic

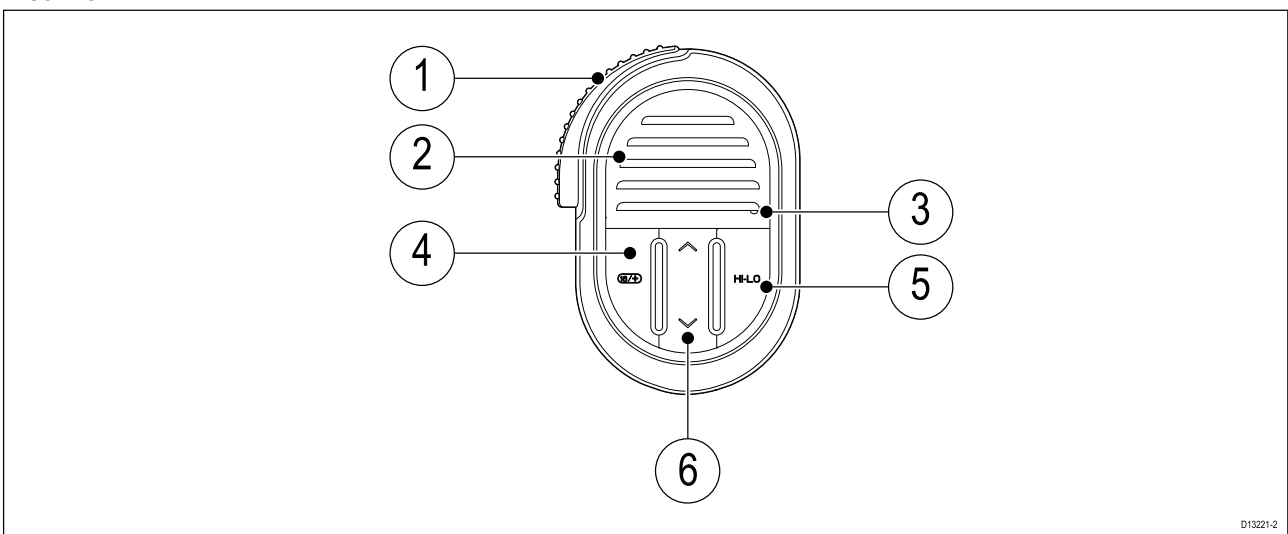

1. **PTT (Push to Talk)** — Press and hold to send a voice message. Release to return to receive mode.

Note: The maximum transmit time is limited to 5 minutes to prevent un-intentional transmissions from occupying the VHF channel.

2. **Speaker**
3. **Microphone location**

4. **16 / +** — When powered on press to switch between priority channels.
5. **HI/LO** — Press to switch between High (25 W) and low (1 W) transmit power.
6. **Channel Up / Channel Down** — Changes the channel up or down.

5.2 Handset controls

Overview of wireless handset controls.

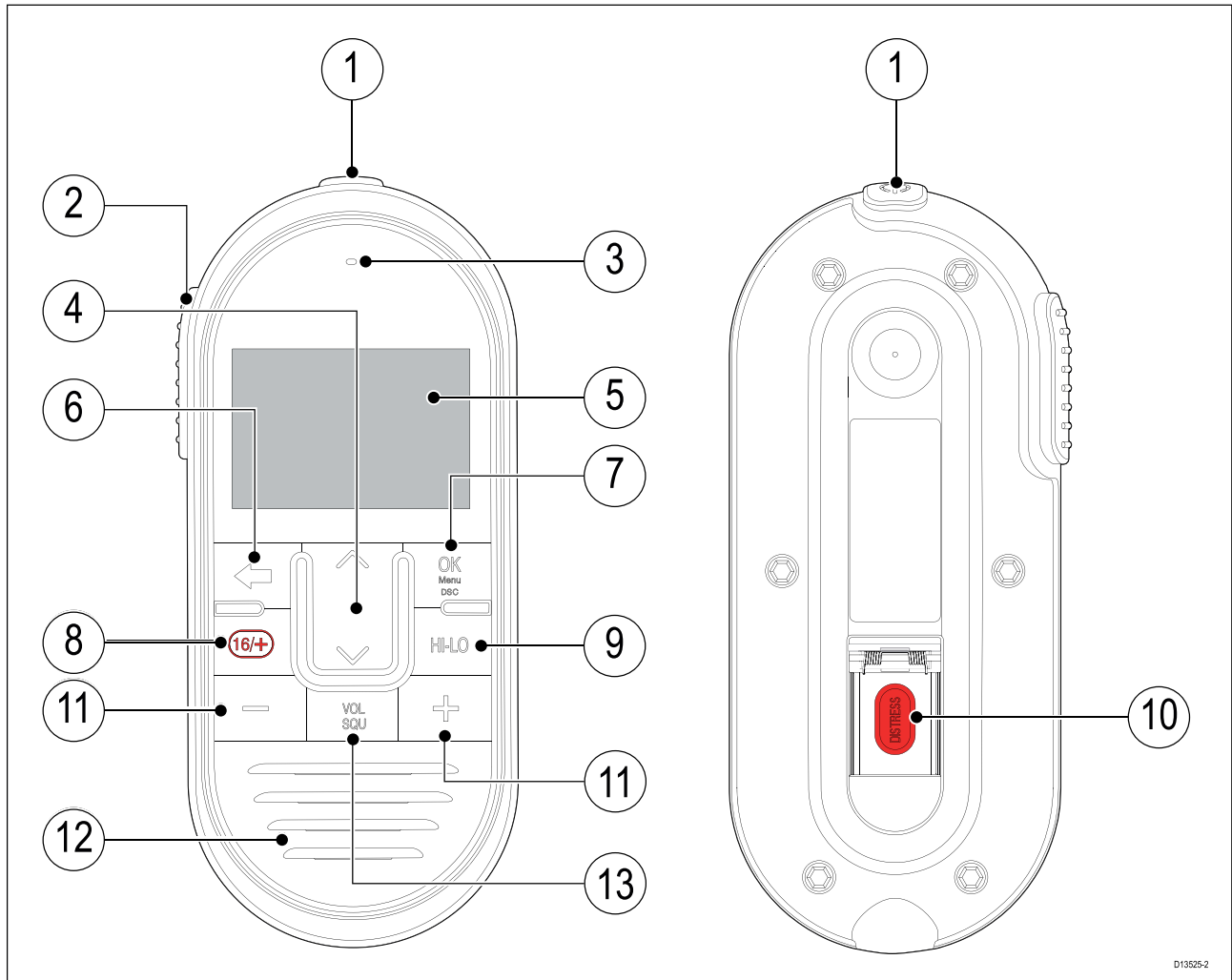

1. **Power** — Press to power the handset on. Press and hold for 3 seconds to power the handset off. Momentary press to access the shortcut list.
2. **PTT (Push to Talk)** — Press and hold to send a voice message. Release to return to receive mode.

Note: The maximum transmit time is limited to 5 minutes to prevent unintentional transmissions from occupying the VHF channel.

3. **Microphone location**
4. **Channel Up** and **Channel Down** — Changes to the next or previous VHF channel, also used to select or adjust options in the menu.
5. **LCD display**
6. **Back** — Go to the previous menu / screen. Press and hold to return to the Homescreen.
7. **OK / menu button** — Press button to access menu / DSC functions and to confirm selections.
8. **16 / +** — When powered on press to switch between priority channels.
9. **HI/LO** — Press to switch between High (25 W) and Low (1 W) transmit power.
10. **DISTRESS** — Lift up the spring-loaded cover and press this button to make a DSC distress call.
11. **Volume Up** and **Volume Down** — Press to adjust volume or squelch intensity up or down.
12. **Built-in speaker**
13. **VOL/SQ** — Press button to switch between volume and squelch controls.

5.3 Powering the unit on

With the radio connected to a power supply the power button is used to switch the radio on and off.

1. Press the **Power** button to power-up the radio.

The startup is displayed.

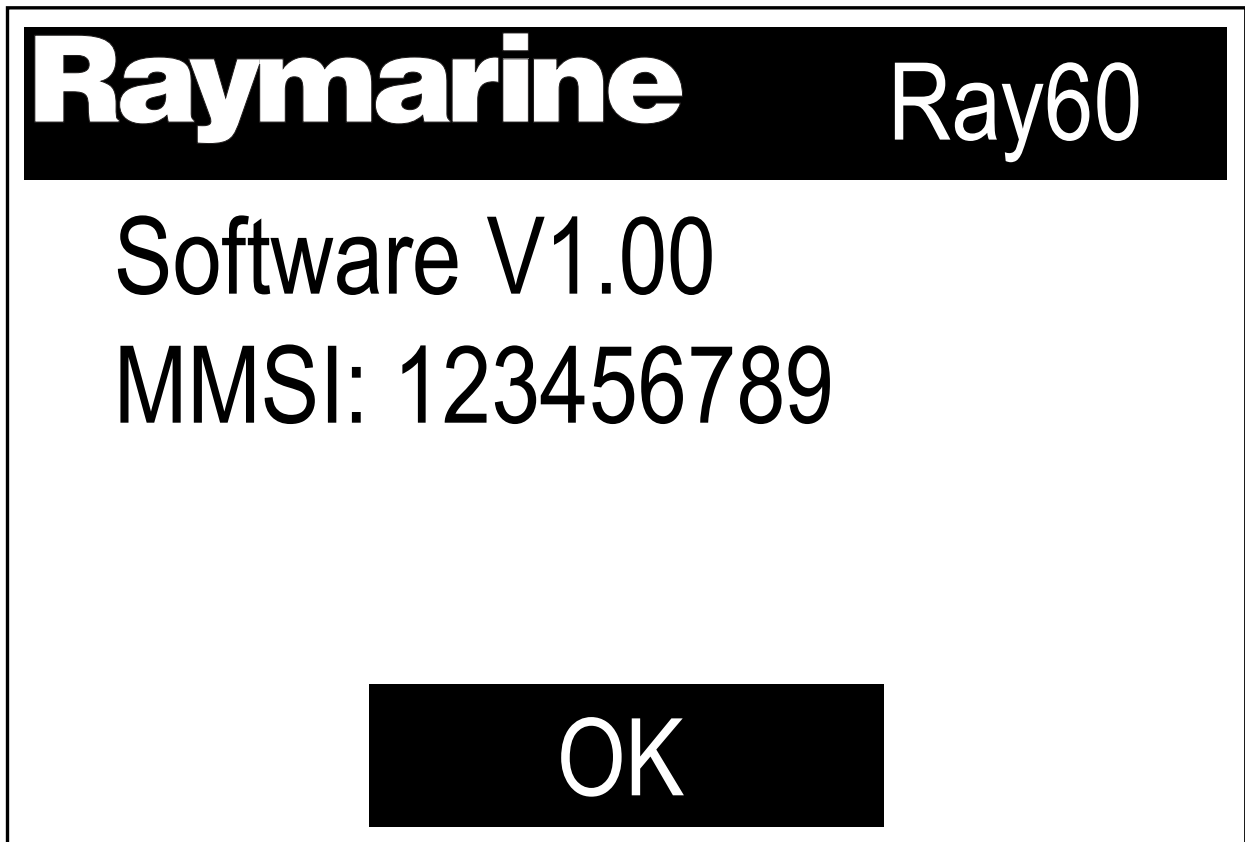

The startup screen will automatically time-out after 5 seconds.

2. Press the **OK** button, or wait for the startup screen to time-out.

The Homescreen is displayed.

Powering the handset

To power the Handset on and off follow the steps below.



D13526-2

With the Base station powered On:

1. Press and hold the **Power** button, located on the top of the Handset, for 2 seconds.
The Handset will power on.
2. To power off the Handset, press and hold the **Power** button for approximately 3 seconds, until the screen turns off.

5.4 Powering the unit off

With the unit powered on:

1. Press and hold the **Power** button for approximately 3 seconds to power the unit off.

5.5 Homescreen overview

The information below describes the on-screen characters and symbols which are shown on the Homescreen..

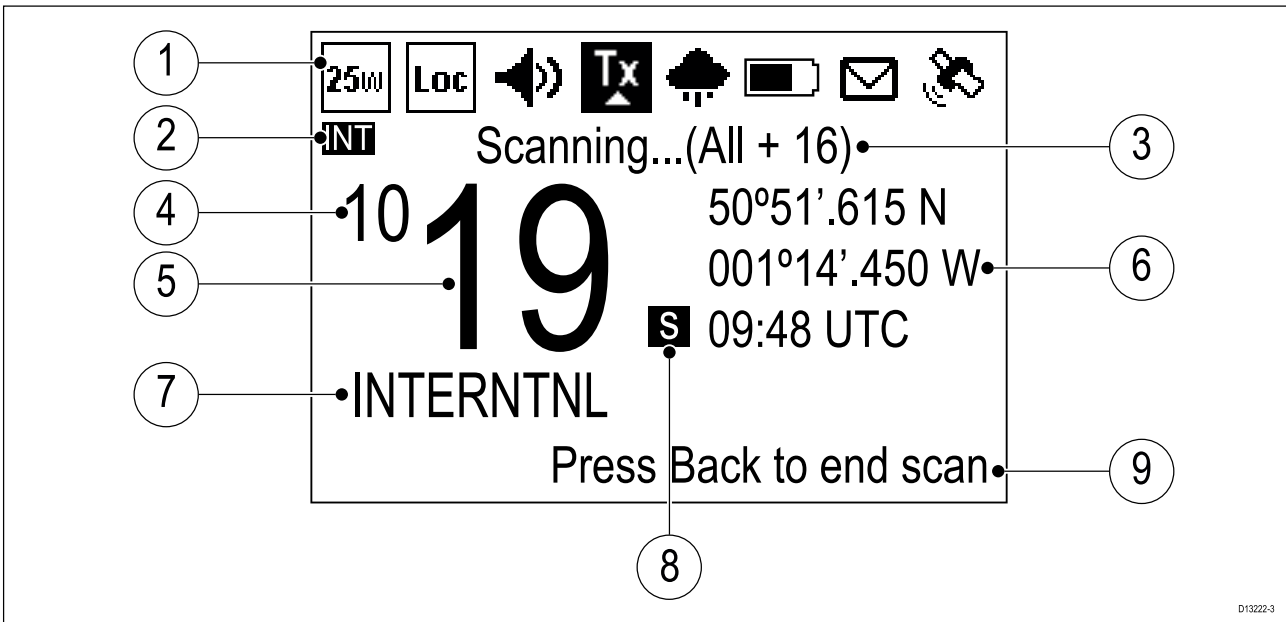

1. **Status bar** — The status bar displays symbols which indicate the current status of the unit.
2. **Frequency band** — Indicates which channel frequency band is in use:
 - USA — United States of America
 - INT — International
 - CAN — Canada
 - WX — Weather



Note: Special licensing is required to receive USA and Canadian channel sets.

3. **Status text** — Indicates the current radio mode e.g.: ATIS Mode active, Weather Alert, Scan mode etc.
4. **New 4 digit channels** — Identifies the first 2 digits when the radio is set to one of the new 4 digit simplex channels.
5. **Channel** — Indicates the current channel number, or the last 2 digits when set to a 4 digit channel..
6. **Location / Time** or **Location / COG/SOG** — Depending on selection displays Location coordinates and current time or Location coordinates and current COG and SOG.
7. **Channel Name** — Indicates the name of the current channel.
8. **Channel type** — Indicates the type of channel:
 - **s** = Simplex — Simplex channels transmit and receive on the same frequency.
 - **d** = Duplex — Duplex channels use separate frequencies to transmit and receive.
9. **Optional text** — Provides extra user guidance.

Status bar symbols

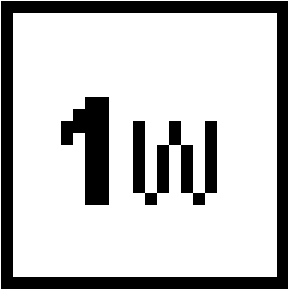
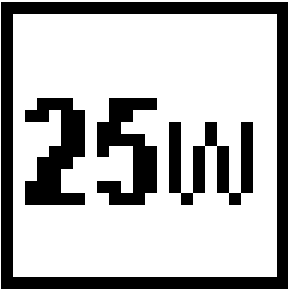
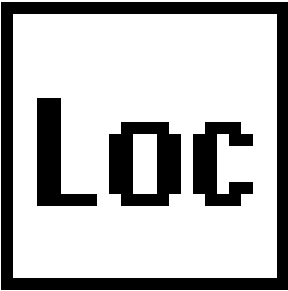
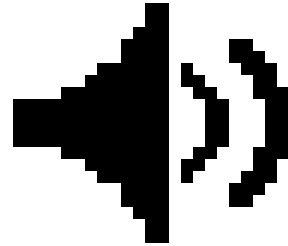
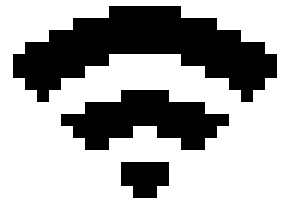
The status bar is used to display symbols that indicate the radio's status.

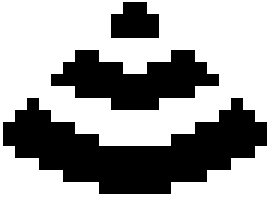
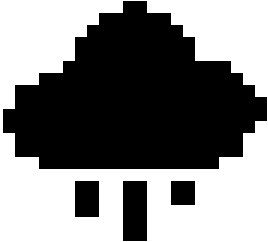
| Symbol | Name | Description |
|-------------------------------------------------------------------------------------|------------|-------------------------------------------------------------------------------------------------------------------------------------------|
|  | Low power | Indicates the radio transmitters is in low power (1 watt) or high power (25 watt) mode |
|  | High power | |
|  | Local | Indicates the radio is in local reception mode, which decreases receiver sensitivity in high traffic areas to decrease unwanted reception |
|  | Fog horn | Indicates that the radio is in Fog horn mode. |
|  | Transmit | Indicates the radio is currently transmitting (e.g. the PTT button is being pressed.) |

| Symbol | Name | Description |
|-------------------------------------------------------------------------------------|-------------------------------|-----------------------------------------------------------------------------------|
|  | Receive | Indicates the radio is currently receiving a transmission |
|  | Weather | Indicates that the weather alerts mode is activated. |
|  | Power supply voltage too low | Indicates the power supply to the radio is below the specified operating voltage. |
|  | Power supply voltage too high | Indicates the power supply to the radio is above the specified operating voltage. |

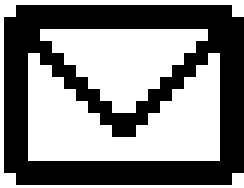
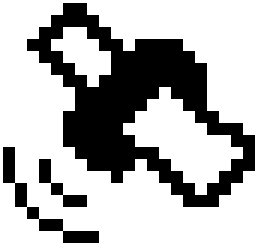
| Symbol | Name | Description |
|-----------------------------------------------------------------------------------|---------|---------------------------------------------|
|  | DSC | Indicates that a DSC call has been received |
|  | GPS Fix | Indicates if the radio has a GPS/GNSS fix. |

Main menu overview

The main menu is accessed by Pressing the **OK** button from the **Homescreen**.

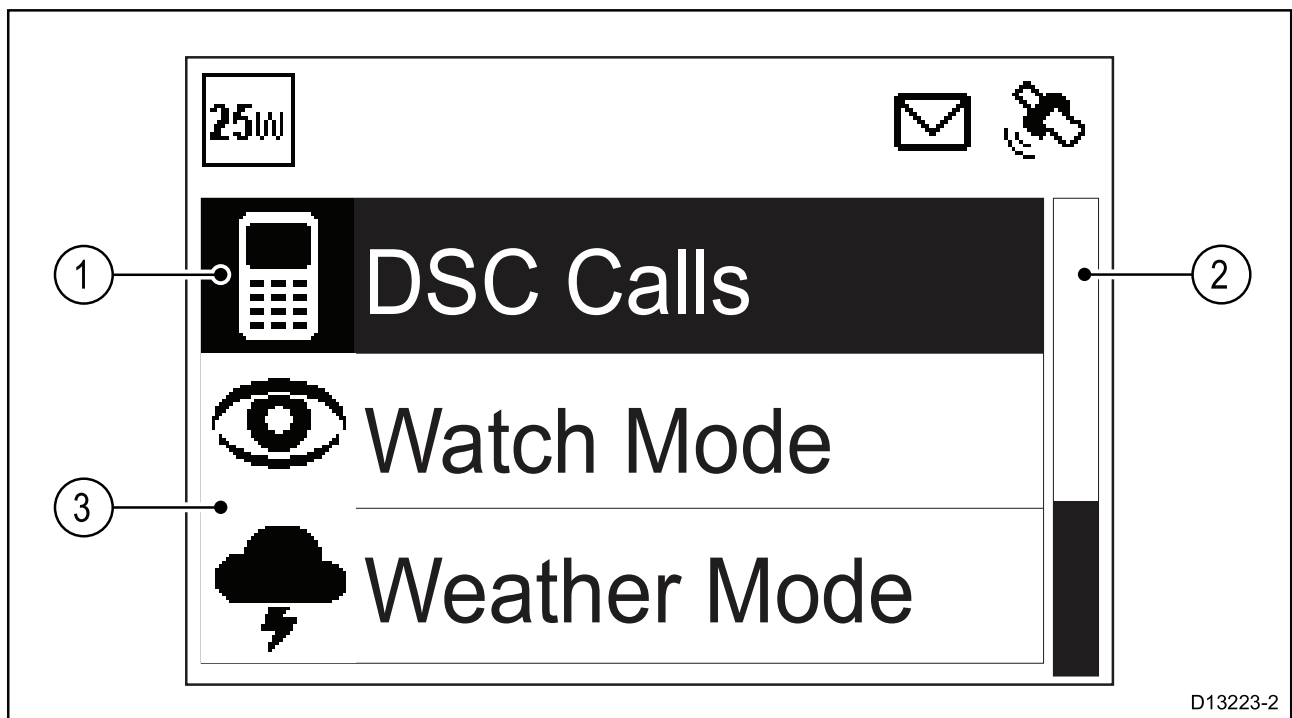

1. Currently selected menu item
2. Scroll bar
3. Menu items

The main menu includes the following items:

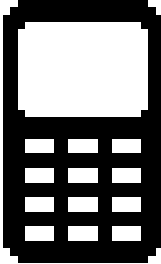
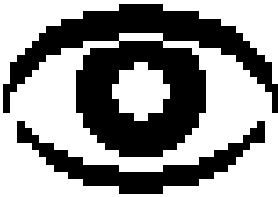
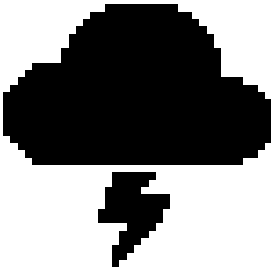
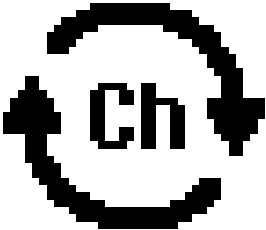
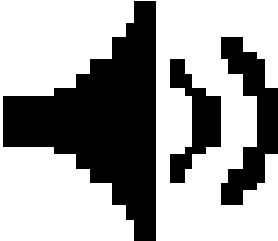
| Symbol | Name | Sub-options |
|-------------------------------------------------------------------------------------|-----------------------------|---------------------------------------------------------------------------------------------------------------------------------------------------------------------------------------------------------------------------------------------------------------|
|  | * DSC Calls | <ul style="list-style-type: none"> • Individual call • Distress call • Position request • Group call • All ships call • Phonebook • Call logs • Test call • DSC set-up |
|  | * Watch Mode | <ul style="list-style-type: none"> • Dual watch • Triple watch • 2nd priority channel |
|  | * Weather Mode | <ul style="list-style-type: none"> • Weather Homescreen |
|  | * Scan Mode | <ul style="list-style-type: none"> • All channels • All channels + 16 • Saved channels • Saved channels + 16 • Edit saved channels |
|  | ** Hail/Fog/Intercom | <ul style="list-style-type: none"> • Hailer • Fog horn • Intercom |

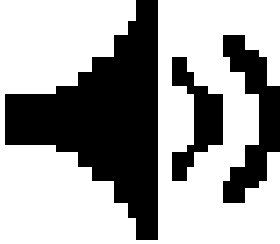
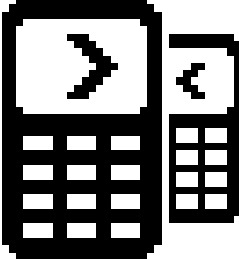
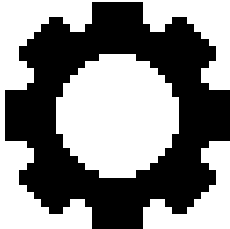
| Symbol | Name | Sub-options |
|------------------------------------------------------------------------------------|---------------------------|----------------------------------------------------------------------------------------------------------------------------------------------------------------------------------------------------------------------------------------------------------------------------------------------------------------------------------------------------------------------------------------------------------------------------------------------------------|
|  | ** Hailer/Fog horn | <ul style="list-style-type: none"> • Hailer • Fog horn |
|  | ** Intercom | <ul style="list-style-type: none"> • Intercom |
|  | Set-up | <ul style="list-style-type: none"> • Display set-up • Language • Units • Power output • Sensitivity • Noise cancelling (Tx) • ** Wireless set-up • Handset name • Key beep • Channel set-up • Weather alerts • GPS set-up • DSC set-up • AIS • Network output • ATIS set-up • Maintenance |

Note:

* Menu items not available when radio has ATIS enabled or if the radio has been pre-programmed in MARCOM-C mode.

** Menu only available when compatible accessories are connected.

5.6 Shortcut list

Pressing the **Power** button once while the radio is switched on will open the **Shortcuts list**. The Shortcuts list can be used to adjust the brightness, contrast and access frequently used functions.

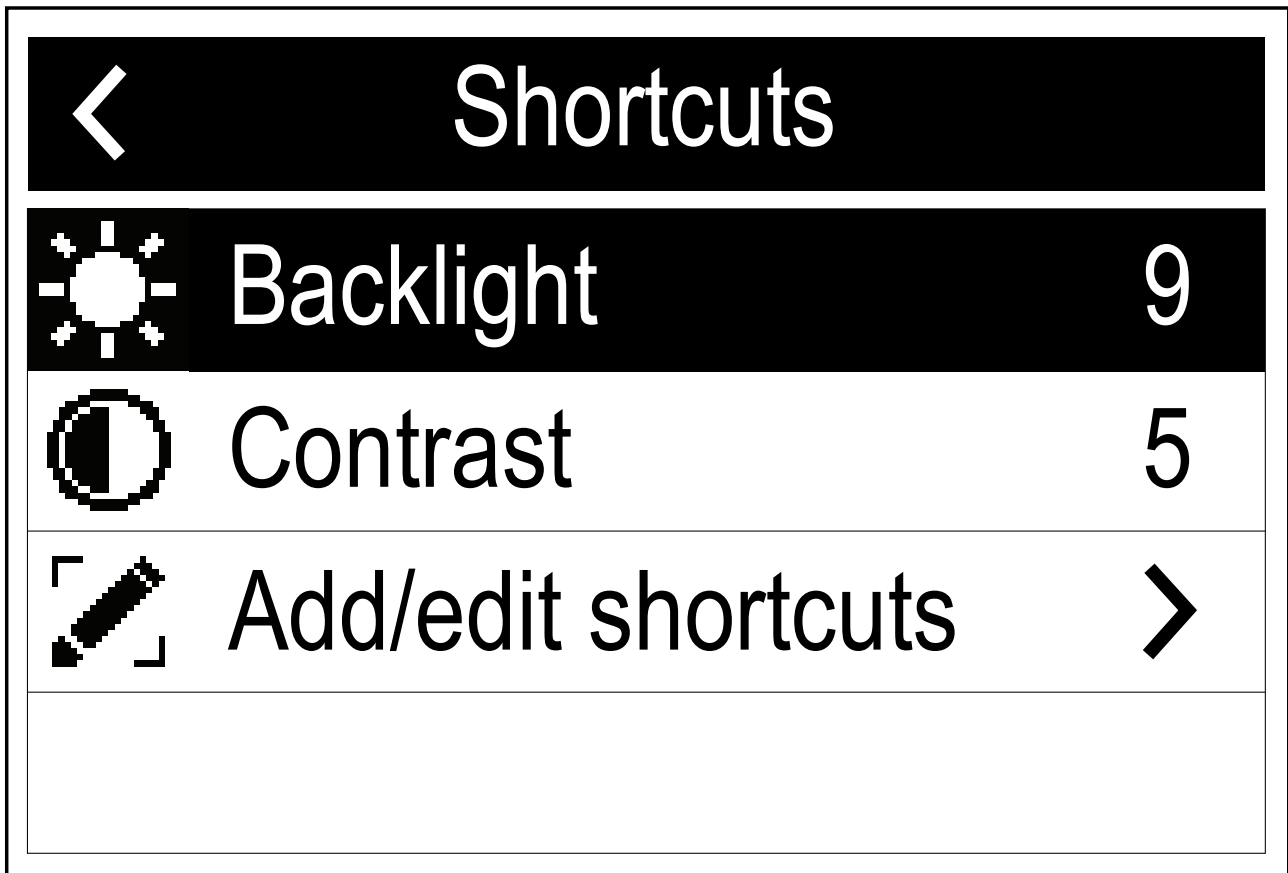

Frequently used functions can be added by selecting **Add/edit shortcuts**.

Adjusting Brightness and Contrast

The LCD Brightness (Backlight) and Contrast can be adjusted using the Shortcuts list.

From any screen:

1. Press the **Power** button.
2. Select **Backlight** or **Contrast**.
3. Adjust the Backlight or Contrast to the desired level using:
 - i. **Channel Up** / **Channel Down** buttons on a connected Handset.
 - ii. **Rotary knob** on the Base station.
4. Press the **Back** button to return to the previous screen.

The Backlight and Contrast settings can also be accessed from the Display set-up menu: **Menu** > **Set-up** > **Display set-up** .

5.7 Shared Brightness

You can set up Shared Brightness groups which enables simultaneous brightness adjustment of all units that are part of the same group.

The following products are compatible with Shared Brightness:

- LightHouse™ 3 MFDs using software version 3.4 or greater.
- LightHouse™ or LightHouse™ 2 powered MFDs.
- SeaTalkng® Instrument displays and Pilot controllers.
- SeaTalkng® VHF DSC Radios.

Any adjustments to the Shared Brightness level will be reflected on all units assigned to the same group.



Multiple brightness groups can be configured. These groups could be used to reflect the physical location of units on your vessel. For example, the units at your helm can be set to one group, and the units on the flybridge can be set to a different group.

Shared Brightness requires:

- all units to be compatible with the Shared Brightness function (see list of compatible units above).
- the **Shared brightness** setting set to On for all units in the brightness group.
- units to be assigned to Network Groups.
- all the displays in that group to be synchronized.

Enabling Shared Brightness

From the **Display Set-up** menu: (**Menu > Set-up > Display Set-up**).

1. Select **Shared Brightness**.
2. Select **Shared Brightness** again to enable Shared Brightness.

If Shared Brightness is already enabled then selecting this menu item will disable Shared Brightness.

3. Select **Group**.
4. Select the group that you want to assign the radio to.

Adjusting the Brightness setting will now change the brightness of all products assigned to that group.

5.8 Initial startup

Unless your radio has been pre-programmed; the first time you power-up your radio you will be requested to select certain options. With the exception of your MMSI and ATIS ID, you will also be requested to enter these options after a factory reset.

After acknowledging the startup screen, unless previously set you will be prompted to make the following selections:

1. **Language selection** — See [5.10 Selecting a language](#) for available languages.
2. **Turn on AIS reception (Ray70 and Ray91 only)** — Enables the built-in AIS receiver. This step is only applicable to radios with a built-in AIS receiver. See [5.11 Switching on the AIS receiver](#) for more information.
3. **Select network type** — Selects which connection to transmit AIS and DSC information on, to connected equipment. This step is only applicable if the AIS receiver was turned on in the previous step. See [5.12 Selecting a network type](#) for available options.
4. **Enter MMSI number** — Required to enable DSC functions. This option is not required after a factory reset, or if the radio has been pre-programmed in MARCOM-C mode, or has ATIS enabled. See [5.13 Entering an MMSI number](#) for more information. If not already selected you will also be prompted to select your network type.
5. **Enter ATIS ID** — Required when the radio will be used in the inland waterways of Europe. This step is only applicable if the radio has been pre-programmed in MARCOM-C mode. See [5.14 Entering an ATIS ID](#) for more information.
6. **Frequency band selection** — Sets the relevant channels for your region. This step is not applicable if the radio has been pre-programmed in MARCOM-C mode. See [5.15 Changing the radio region](#) for more information.

5.9 Accessing the menu

The radio's various options and settings are contained within the menu.

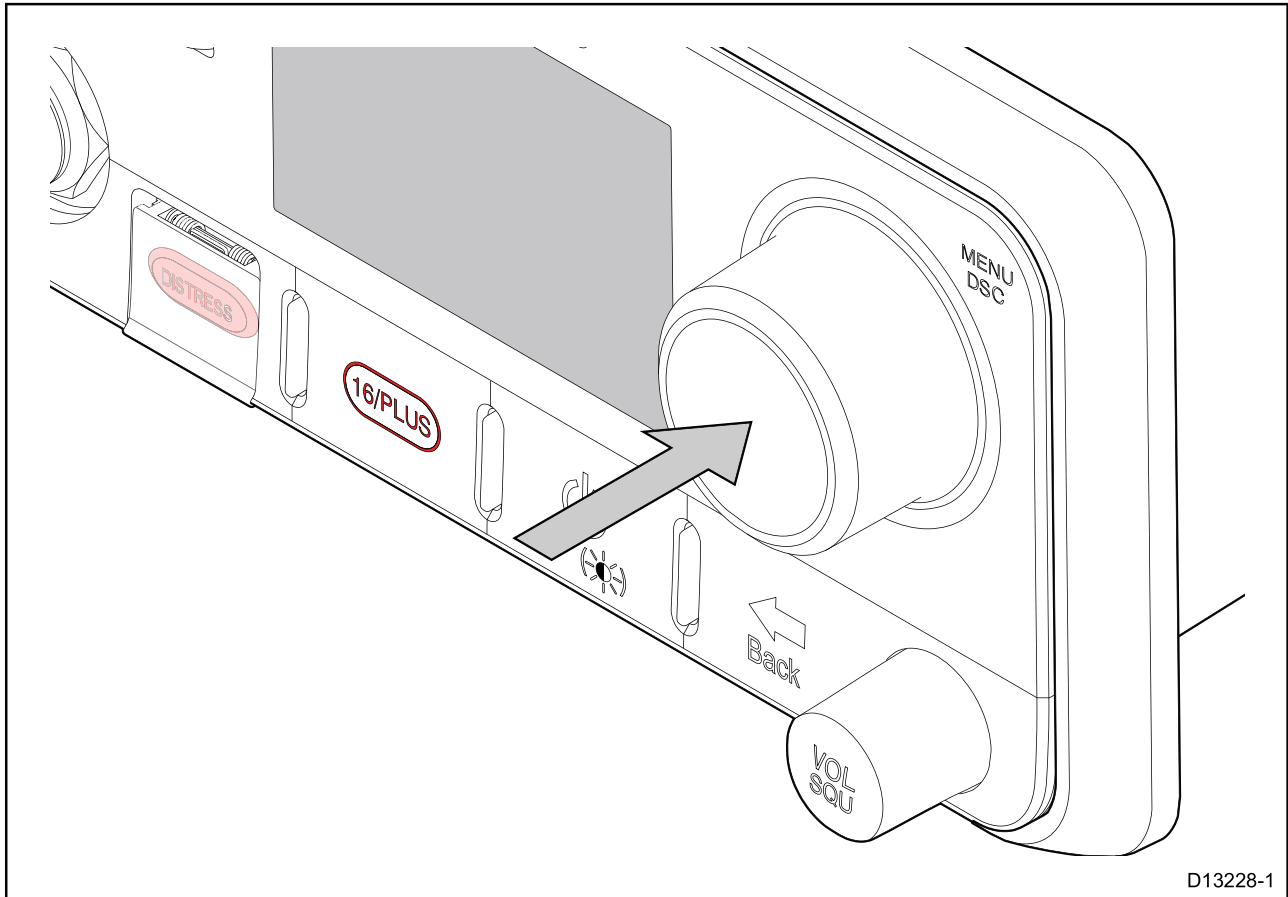

D13228-1

From the Homescreen.

1. Press the **Rotary knob's OK** push button.

5.10 Selecting a language

The language the radio uses can be changed.

From the Main menu:

1. Select **Set-up**.
2. Select **Language**.

The languages available are:

- **English (default)** — English
- **Español** — Spanish
- **Français** — French
- **Deutsch** — German
- **Italiano** — Italian

3. Select the language that you want the radio to be set to.

The User interface language is changed to the selected language.

5.11 Switching on the AIS receiver

If your radio includes a built-in AIS receiver then it can be enabled and disabled as follows:

From the Main menu:

1. Select **Set-up**.
2. Select **AIS**.
3. Select **On** to switch the receiver on, or select **Off** to switch the receiver off.

5.12 Selecting a network type

When connecting your radio to other devices it is important to ensure you select the network connection and type that you want data to be transmitted over.

From the Main menu:

1. Select **Set-up**.
2. Select **Network output**.

The following network types are available:

- *NMEA 2000 (default)*
- *0183 High speed*
- *0183 Std speed*

3. Select the network type relevant to the devices connected to your radio. If your radio is not connected to any other devices any option can be selected.

*Selecting **0183 Std speed** will disable the built-in AIS receiver, where applicable.*

The **Network output** setting determines the baud rate of the NMEA 0183 input:

| Network output setting | NMEA 0183 input baud rate |
|-------------------------------|----------------------------------|
| NMEA 2000 | Standard speed (4,800) |
| NMEA 0183 High Speed | High speed (38,400) |
| NMEA 0183 Standard Speed | Standard speed (4,800) |

5.13 Entering your MMSI number

To program your radio with your MMSI number follow the steps below.

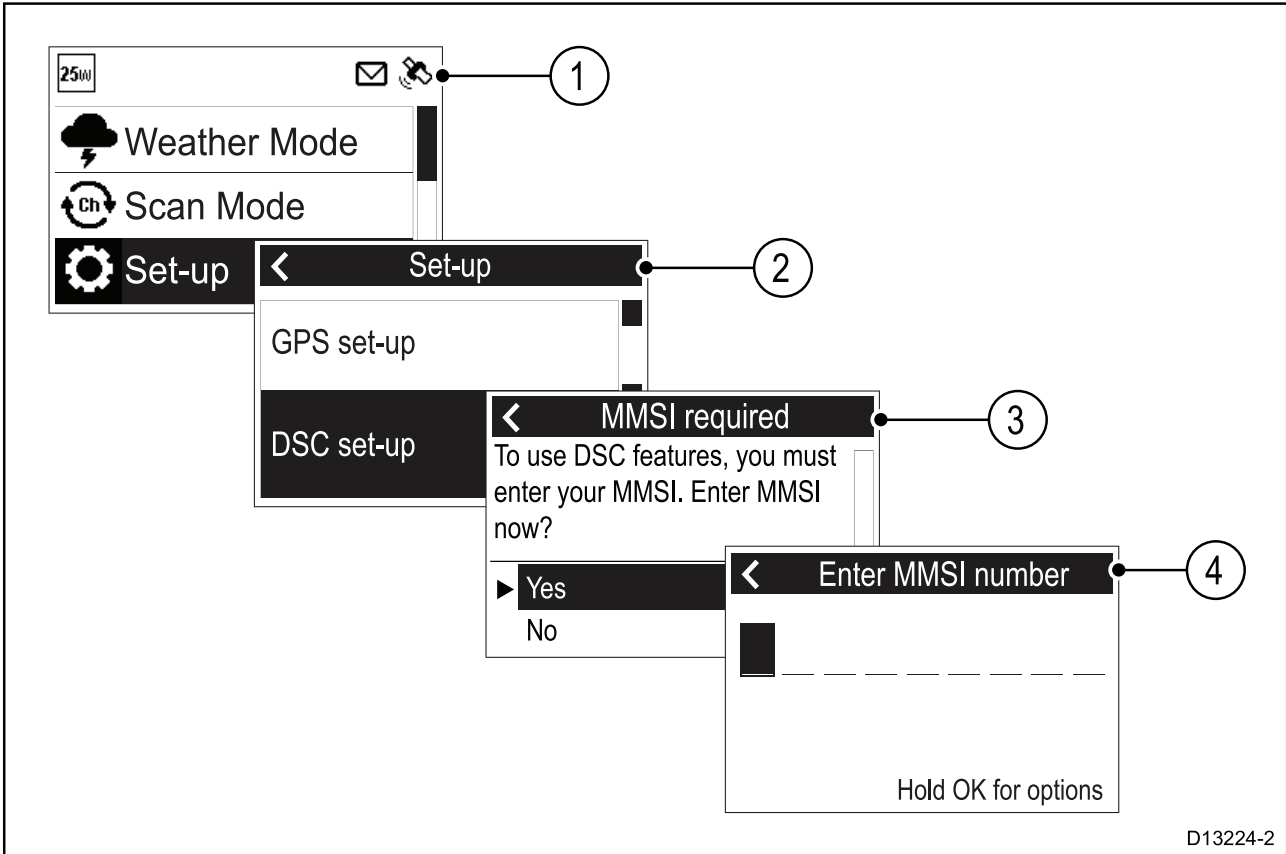

From the Set-up menu: (**Menu > Set-up**)

1. Select **DSC set-up**.
2. Select **MMSI**.

*The **MMSI required** message will be displayed if no MMSI number has been set.*

3. Select **Yes**.
4. Use the **Rotary knob** or the **Channel Up** and **Channel Down** buttons on a Raymic handset to cycle through the available numbers and press **OK** to confirm each number and move to the next digit.

You should only enter the unique 9 digit MMSI number provided by your licensing authority.

MMSI numbers starting with a '0' are only used for groups and coast stations. If you enter a '0' as the first digit the radio will assume you are entering a coast station MMSI and automatically assign a '0' as the second digit; this is to ensure a group MMSI is not entered as the radio's unique MMSI.

5. Press the **Back** button at any time to edit digits you have already entered.
6. Press and hold the **OK** button to display options to **Move cursor** back and forward through the digits.
7. When the final digit is confirmed select **DONE**.

Example

← Enter MMSI number

1 2 3 4 5 6 7 8 9

Done

8. The MMSI is displayed onscreen, check that it is correct, then:
 - i. Select **Yes – Save**, or
 - ii. if the number entered is not correct select **No – Retry**.

Caution: MMSI and ATIS ID entry

You can only enter the MMSI number and ATIS ID once!

If you store an incorrect MMSI number or ATIS ID in your product, it will have to be reset by an authorized **Raymarine**® dealer.

5.14 Entering your ATIS ID

A unique ATIS ID must be entered before ATIS mode can be enabled.

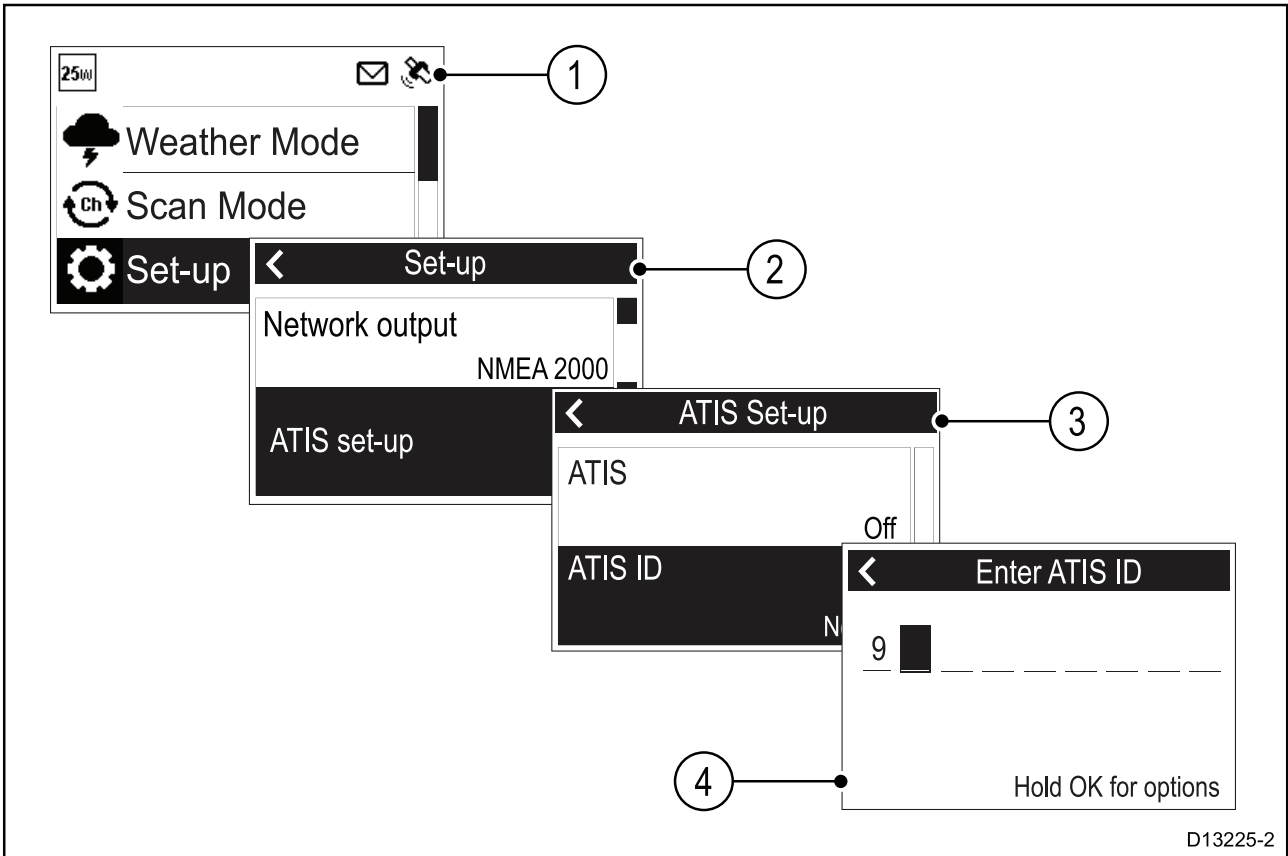

From the Main menu.

1. Select **Set-up**.
2. Select **ATIS set-up**.
3. Select **ATIS ID**.

***Not set** will be displayed if no ATIS ID has been set.*

The first digit is set to a '9' and cannot be changed, this is because all ATIS IDs start with a '9'.

As most ATIS IDs consist of a '9' followed by your 9 digit MMSI number; if your radio already has an MMSI number the ATIS ID will be pre-filled in this format.

4. If the ATIS ID has been pre-filled, check it carefully against your issued ATIS ID.
5. To enter your ATIS ID manually, use the **Rotary knob** or the **Channel Up** and **Channel Down** buttons on a Raymic handset to cycle through the available numbers and press **OK** to confirm each number and move to the next digit.

You should only enter the unique 10 digit ATIS ID provided by your licensing authority.

6. Press the **Back** button at any time to edit digits you have already entered.
7. Press and hold the **OK** button to display options to **Move cursor** back and forward through the digits.

8. When the final digit is confirmed select **DONE**.

Example

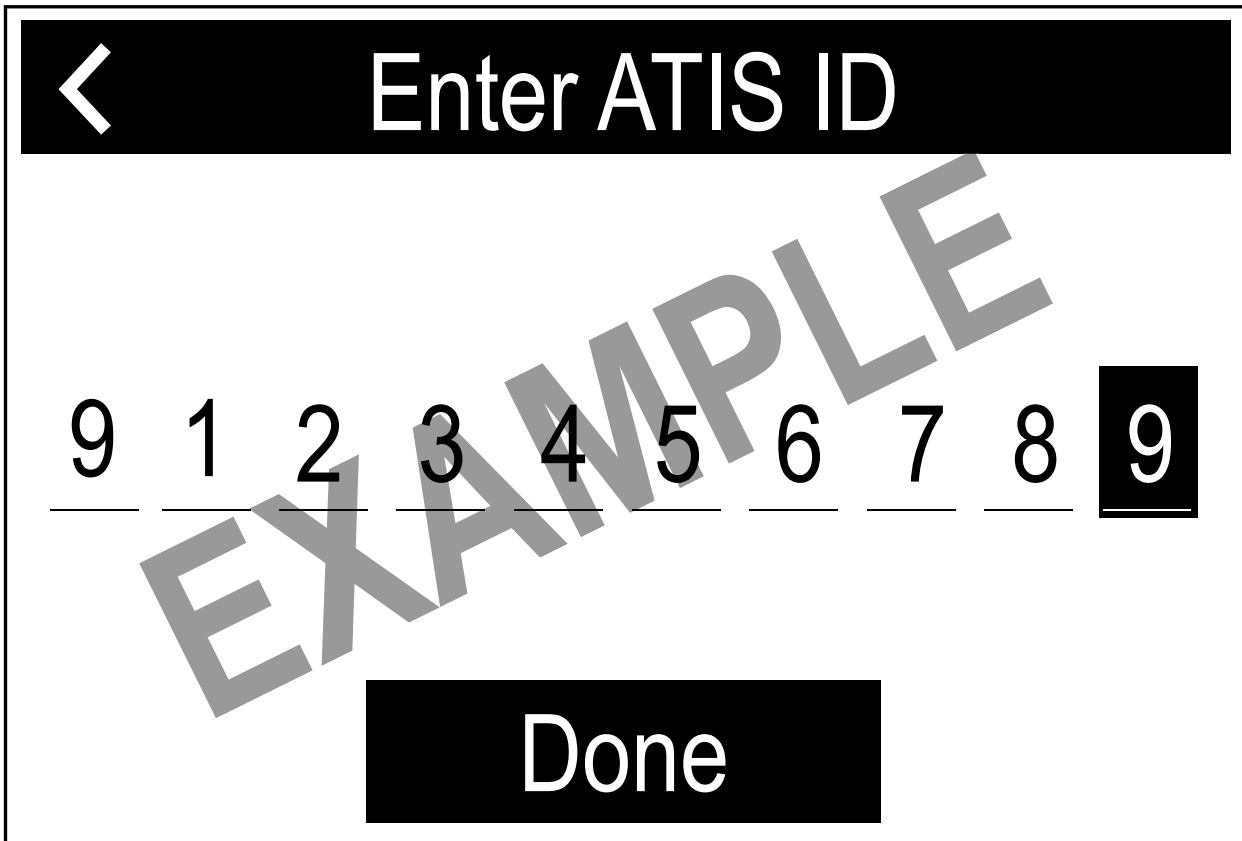

9. The ATIS ID is displayed onscreen, check that it is correct, then:

- i. Select **Yes – Save**, or
- ii. if the number entered is not correct select **No – Retry**.

Caution: MMSI and ATIS ID entry

You can only enter the MMSI number and ATIS ID once!

If you store an incorrect MMSI number or ATIS ID in your product, it will have to be reset by an authorized **Raymarine**® dealer.

Enabling and disabling ATIS mode

ATIS is a European system used on some inland waterways. A unique ATIS ID must be entered before ATIS mode can be enabled.

With ATIS mode enabled the radio's region will be fixed to the INT (international) frequency band and the following functions are disabled:

- DSC functions
- Watch Mode
- Scan Mode
- High/low power is restricted on certain channels

From the Main menu.

1. Select **Set-up**.
2. Select **ATIS set-up**.
3. Select **ATIS**.

If no ATIS ID has been set then you will be requested to enter one before ATIS mode is enabled.

4. If an ATIS ID has already been set then select **On** to enable ATIS mode or **Off** to disable ATIS mode.

5.15 Changing the radio region

Prior to using the radio you must set the Frequency band to the region your radio will be used in.

From the Main menu:

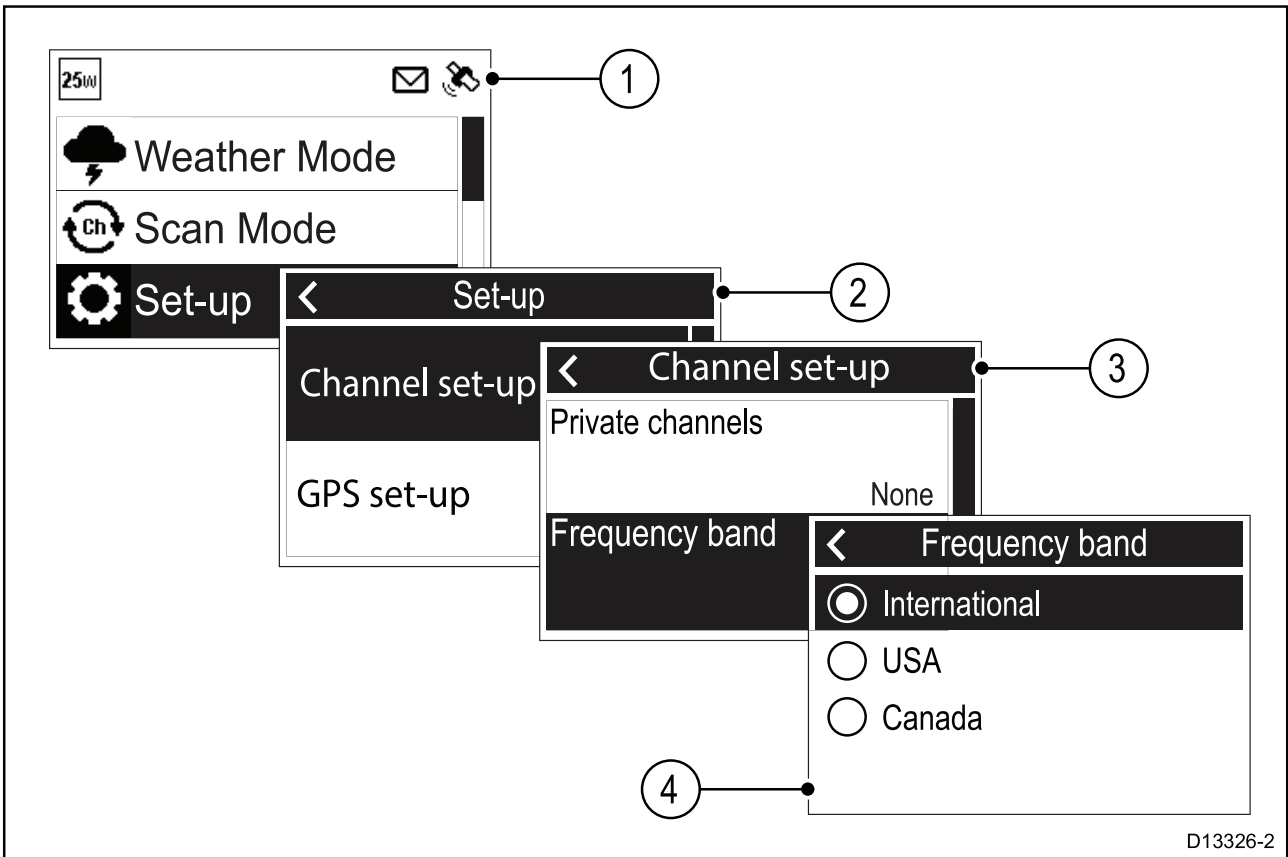

D13326-2

1. Select **Set-up**.
2. Select **Channel set-up**.
3. Select **Frequency band**.
4. Select the relevant region from the list.

The available options are:

- **International**
- **USA**
- **Canada**

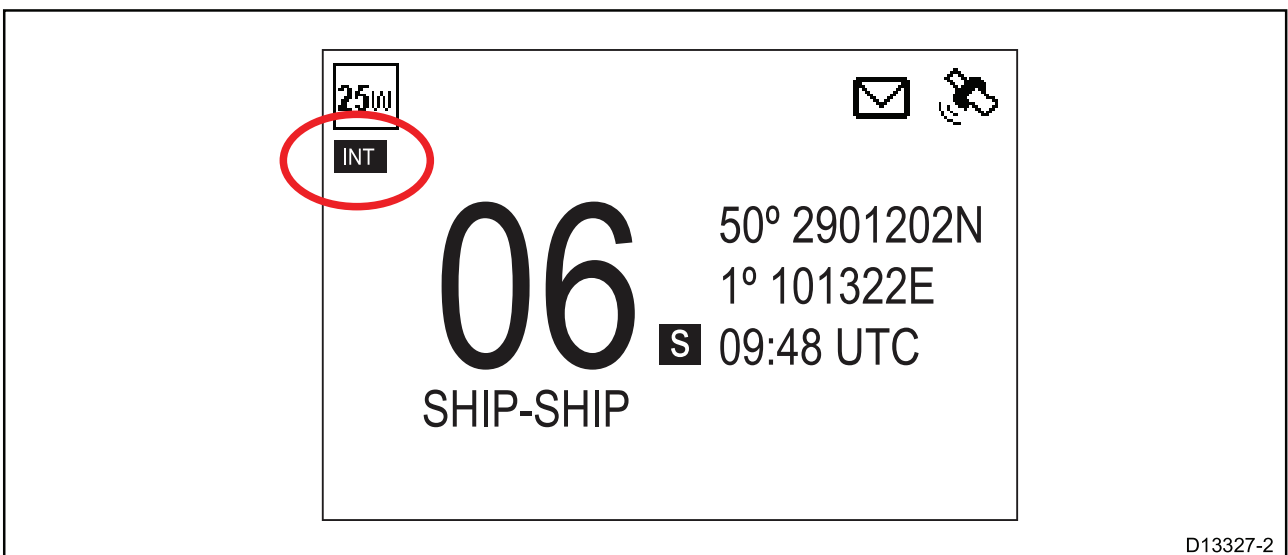

D13327-2

An icon is displayed on the Homescreen that identifies which region has been set.

5.16 Switching between high and low transmit power

You can switch transmit power using the HI/LO button on the Handset / Fismic.

The transmit power can also be changed from the **Set-up** menu: **Menu > Set-up**

1. Select **Power output**.

Selecting the Power output option will switch between High (25 watt) and Low (1 watt) power output.

5.17 GNSS (GPS) set up

If your radio has a GNSS (GPS) position fix then the following information can be displayed:

- latitude
- longitude
- UTC time
- COG and SOG

When position data is available the satellite icon is displayed onscreen.

If no position data is available then the latitude, longitude and time can be entered manually so that it can be included in DSC distress transmissions.

Position data received from other vessels can be displayed on a connected Raymarine® multifunction display.

Enabling and disabling the internal GNSS (GPS)

From the **GPS set-up** menu: **Menu > Set-up > GPS set-up**

1. Select **Integrated GPS**.

Selecting **Integrated GPS** will switch the radio's internal GNSS receiver On and Off.

Switching between internal and external antenna

Your radio's built-in GNSS (GPS) receiver includes an internal antenna, to improve performance you can connect an external antenna. You must select which antenna you are using.

From the **GPS set-up** menu: **Menu > Set-up > GPS set-up**

1. Select **GPS antenna**.

Selecting **GPS antenna** will switch between the internal antenna and external antenna.

No position data

If no position data is available or position data becomes unavailable; after 10 minutes an audible warning is sounded, the GNSS (GPS) icon flashes and the **No position data** message is displayed.

Once the warning has been acknowledged the GNSS (GPS) icon will continue to flash. The **No position data** warning is repeated every 4 hours if position data is still unavailable, has not been entered manually or has been entered manually but over 23.5 hours ago.

If position data has been entered manually the display alternates between displaying the manual position and time and the **Manual Position** message. If the manually entered position has not been updated in the last 4 hours the GNSS (GPS) icon flashes and an audible warning is sounded. This warning will be repeated every 4 hours until position is manually updated or position data becomes available.

Where no position data is available or has not been manually updated for 23.5 hours then position data will change to '9's and time will change to '8's.

Entering position manually

If GPS position data is not available it can be entered manually.

From the **GPS set-up** menu: **Menu > Set-up > GPS set-up**.

1. Select **Set manual position**.

The Manual position screen requires you to input latitude, longitude and UTC time.

2. Use the **Rotary knob** or the **Channel Up** and **Channel Down** buttons on a Raymic handset to cycle through the available numbers and press **OK** to confirm each number and move to the next digit.
3. When the relevant information has been entered select **OK** to confirm the details.

Selecting (GNSS) GPS information to display

You can change the GNSS (GPS) data that is displayed on the Homescreen.

From the **GPS set-up** menu: **Menu > Set-up > GPS set-up**.

1. Select **Homescreen display**.

Selecting Homescreen display will switch between **Location & time** and **Location & COG/SOG**.

The **Homescreen display** option is also available from the **Display set-up** menu: **Set-up > Display set-up > Homescreen display**.

Setting time format and offset

You can change the Format and Offset that is applied to the time displayed onscreen.

From the **Units** menu: **Menu > Set-up > Units**.

1. Select **Time format**.

Selecting Time format will switch between **12 hour** and **24 hour** format.

2. Select **Time offset**.

3. Adjust the offset to the desired value using the **Rotary knob** or the **Channel Up** and **Channel Down** buttons on a Raymic handset.

4. Select **OK** to confirm the selection.

5.18 Station priority (Ray63 and Ray73 only)

The Ray63 and Ray73 can have a Local Fismic, connected to the front connector, and a Raymic (remote) handset, connected to the rear connector.

The following rules apply to station priority:

- The Local station always takes priority over the Remote station.
- Unless a Distress call is in progress, any button press on the Local station will take control from the Remote station.
- If the Remote station is inactive for 3 seconds, the Local station can take control and complete an incomplete Distress call.
- The Local station can interrupt the Remote stations's voice broadcasts by pressing the **PTT** button.
- The Local station will retain control for 3 seconds after the last button press.
- The information on the station which has control is repeated on the other station's display.

Chapter 6: Wireless handset stations

Chapter contents

- [6.1 Wireless handsets on page 118](#)
- [6.2 Connecting a wireless handset to the hub on page 120](#)
- [6.3 Connecting the wireless speaker to the Wireless handset on page 123](#)
- [6.4 Wireless set-up menu options on page 124](#)

6.1 Wireless handsets

Wireless handsets are compatible with the Ray63 and Ray73 VHF DSC radios. Using the optional wireless accessories you can create up to 2 fully functional wireless handset stations.

As a minimum the Wireless hub (A80540), Wireless hub adaptor cable (R70739) and Wireless handset (A80544) are required to create a wireless handset station. Additionally a Wireless speaker (A80543) can be connected to each Wireless handset.

After connecting your Wireless hub to the Second station connector on the rear of your Ray63 / Ray73 Base station, the process for setting up a wireless handset station should be:

1. Fully charge the Wireless handset.
2. Connect the Wireless handset to the Wireless hub.
3. If required, connect a Wireless speaker to the Wireless handset.



Warning: Retain a wired handset station

A wired handset station should always be connected and available.

Wireless handset charging

When inserted into the wireless handset charging holster the wireless handset will be charged using inductive charging.

Attention

Ensure your wireless handset is fully charged before use.

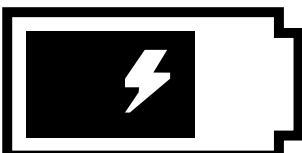
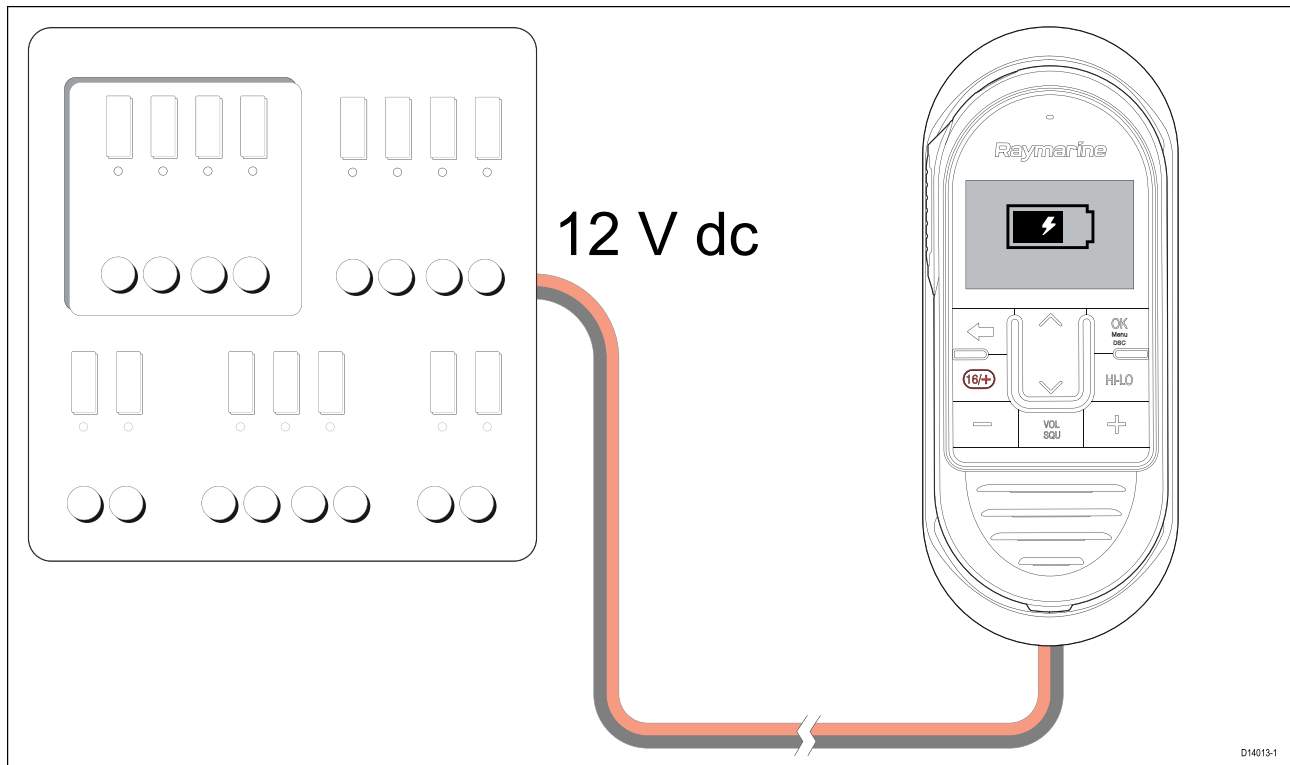

Charging

Whilst charging a battery symbol will gradually fill up.

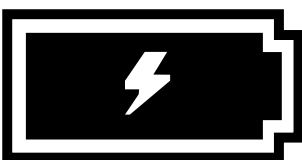

Charged

When fully charged the battery symbol will be full.

With the Handset powered on the battery symbol will be displayed in the status bar at the top of the screen.

With the handset powered off the battery symbol is displayed fullscreen.

6.2 Connecting a wireless handset to the hub

Wireless handsets must be connected to the radio via a Wireless hub.

When the Wireless handset is powered on for the first time you will need to connect it to a Wireless hub.

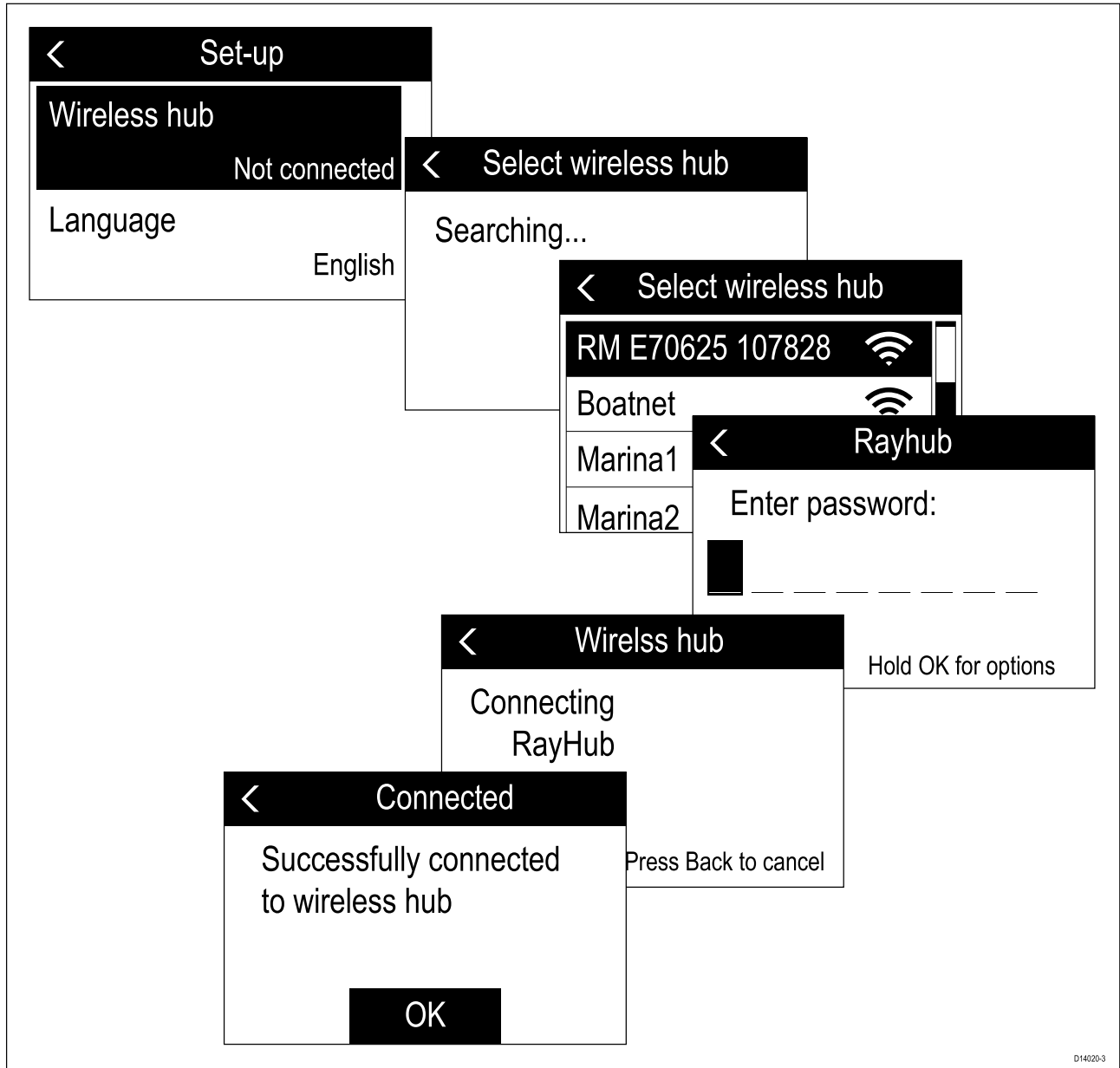

1. Select **Wireless hub**.
The handset will display a list of wireless devices in range.
2. Select your Wireless hub from the list.

The Wireless hub's default name is 'RM' followed by the 6 digit part number and 7 digit serial number of the radio that the Wireless hub is connected to (e.g.: Radio part number: E70625 and serial number: 1070828 = Hub name: RM E70625 107828).

3. Enter the password.

*You can check the Wireless hub's password using a Wired handset by selecting: **Menu > Set-up > Wireless set-up > Wireless hub set-up > Password**.*

The handset will now connect to the Wireless hub.

4. Select **OK**.

Checking the Wireless hub's password

You can check the Wireless hub's password at anytime using a Wired handset.

1. Select **Menu**.
2. Select **Set-up**.
3. Select **Wireless set-up**.
4. Select **Wireless hub set-up**.
5. Select **Password**.

The current password is displayed.

Changing your wireless hub's password

If desired you can change the Wireless hub's default password using a Wired handset.

1. Select **Wireless hub set-up** from the **Wireless set-up** menu: (**Menu > Set-up > Wireless set-up > Wireless hub set-up**).
2. Select **Password**.
3. Use the **Channel Up**, **Channel Down** and **OK** buttons to change the default password.

The password can use up to 8 characters. For the most secure password use a variety of upper and lower case letters, numbers and symbols.

4. When finished, select **OK** to confirm.
5. Re-connect your Wireless handset to the hub following the [6.2 Connecting a wireless handset to the hub](#) procedure.

Note:

- While the password change is being applied the **Wireless set-up** menu will be unavailable.
- Ensure you make a note of your Hub's new password.

Changing the hub's wireless channel

If you experience interference with your wireless handset station then you can change the wireless channel used by the hub to a channel that is less congested with Wireless signals.

You must use a Wired handset to change the Hub's wireless credentials.

1. Select **Wireless hub set-up** from the **Wireless set-up** menu: (**Menu > Set-up > Wireless set-up > Wireless hub set-up**).
2. Select **Wireless channel**.
3. Select a wireless channel.

Channels 1 to 13 are available, use a wireless network analyzer to find the least congested channel. The preferred wireless channels are 1, 6 and 11 as these overlap with the fewest other wireless channels, however if these channels are congested then try others.

Note:

- While the channel change is being applied the **Wireless set-up** menu will be unavailable.
- Your Wireless handset will automatically reconnect to the hub using the new channel.

Changing the Wireless hub's name

You can change the name or SSID of your Wireless hub at anytime.

You must use a Wired handset to change the Hub's wireless credentials.

1. Select **Wireless hub set-up** from the **Wireless set-up** menu: (**Menu > Set-up > Wireless set-up > Wireless hub set-up**).
2. Select **Name**.
3. Use the **Channel Up**, **Channel Down** and **OK** buttons to change the default name.

The name can use up to 10 characters.

4. When finished, select **OK** to confirm.

Note:

- While the channel change is being applied the **Wireless set-up** menu will be unavailable.
- Your Wireless handset will automatically reconnect to the hub using the new name.

6.3 Connecting the wireless speaker to the Wireless handset

You can connect a Wireless speaker to your Wireless handset.

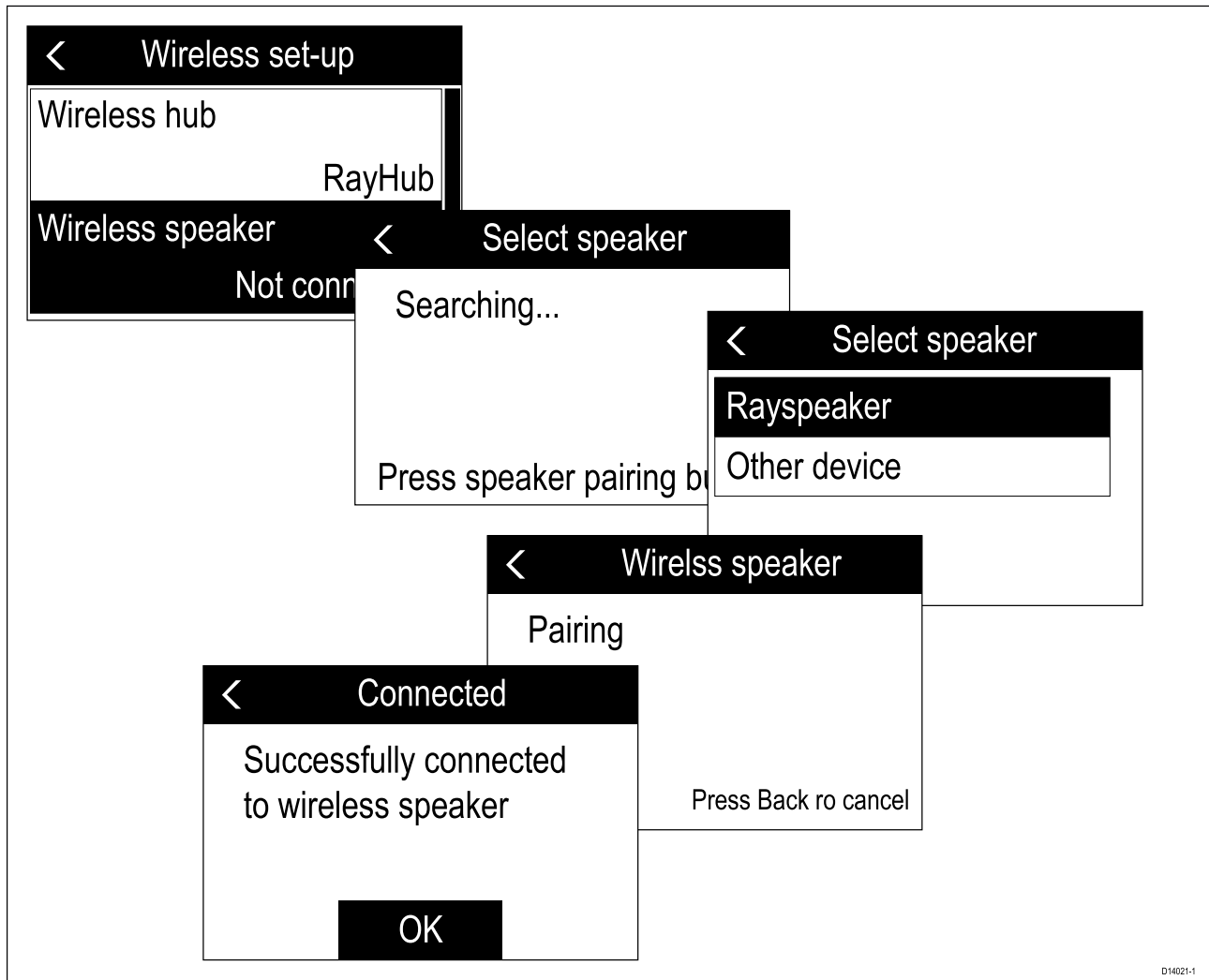

1. Power on the Wireless speaker.
2. Press the **Pairing** button on the front of your Wireless speaker to pair with a Wireless handset for the first time.
3. Using the Wireless handset, select **Wireless speaker** from the **Wireless set-up** menu: **Menu > Maintenance > Wireless set-up**
The handset will search for available devices.
4. Select your Wireless speaker from the list.
The Wireless handset will now pair with the Wireless speaker.
5. Select **OK**.

The Wireless handset's audio will now be heard through the Wireless speaker.

Note:

- You can only output audio to 1 speaker from the same handset.
- If the pairing is unsuccessful, power the wireless speaker off and then back on again and repeat the process.

Disconnecting a Wireless speaker

To disconnect your Wireless speaker from the Wireless handset follow the steps below:

With the speaker connected to the handset:

1. Press the **Pairing** button on the front of the speaker.
2. Once disconnected the speaker can be connected to any Wireless handset by following the [6.3 Connecting a wireless speaker to the wireless handset](#) procedure.

6.4 Wireless set-up menu options

The Wireless set-up menu is available when a Wireless hub is connected.

| Menu item | Description | Options |
|----------------------------|-----------------------------------------------------------------------------------------------------------------------------------------------------------------------------------------------------------------------------------------|-----------------------------------------------------------------------------------------------------------------------|
| Wireless hub | Enables you to search for and connect to a Wireless hub. | List of available networks. |
| Wireless hub set-up | Provides access to the Wireless hub's settings. <div style="border: 1px solid black; padding: 5px; width: fit-content;"> <p>Note: The Wireless hub set-up menu can only be accessed using a Wired handset.</p> </div> | <ul style="list-style-type: none"> • Wireless hub name • Password • Wireless channel |
| Wireless speaker | Enables you to search for and connect to a Wireless speaker. | Search for devices. |

Wireless hub set-up menu options

Note:
The Wireless hub set-up menu can only be accessed using a Wired handset.

| Menu item | Description | Options |
|-------------------------|-----------------------------------------------------------------------------------------------------------------------------------------------------------------------------------------------------------------------------------------------------|------------------|
| Hub name | The Wireless hub's default name is 'RM' followed by the 6 digit part number and 7 digit serial number of the radio that the Wireless hub is connected to (e.g.: Radio part number: E70625 and serial number: 1070828 = Hub name: RM E70625 107828). | Edit hub name |
| Password | You can change the password to any alphanumeric (including standard symbols) password using up to 8 characters. | Change password |
| Wireless channel | Enables you to change the 2.4Ghz channel used by the Wireless hub. | Channels 1 to 13 |

Wireless handset not connected menu

When a connection to a Wireless hub is not available or connection is cancelled, the following menu options will be displayed on the Handset.

| Menu item | Description | Options |
|---------------------|----------------------------------------------------------|-------------------------------------------------------------------------------------------------------------------------------------------------------------------------------------------|
| Wireless hub | Enables you to search for and connect to a Wireless hub. | List of available networks. |
| Language | Enables selection of the user interface language. | <ul style="list-style-type: none"> • English — English • Español — Spanish • Français — French • Deutsch — German • Italiano — Italian |
| Backlight | Provides access to the Backlight level | <ul style="list-style-type: none"> • 1 to 9 • Off |

| Menu item | Description | Options |
|------------------|---------------------------------------------------------------|------------------------------------------------------------------------------------------------|
| Contrast | Provides access to the Contrast level | <ul style="list-style-type: none">• 1 to 10 |
| Key beep | Enables adjustment of the audible beep when pressing buttons. | <ul style="list-style-type: none">• Off• Quiet (default)• Loud |

Chapter 7: Digital selective calling (DSC)

Chapter contents

- 7.1 Digital Selective Calling (DSC) on page 128
- 7.2 Distress calls on page 130
- 7.3 Urgency calls on page 136
- 7.4 Safety calls on page 137
- 7.5 Individual (routine) calls on page 138
- 7.6 Group calls on page 139
- 7.7 Position requests on page 140
- 7.8 Phonebook on page 141
- 7.9 Call logs on page 142
- 7.10 Test calls on page 143
- 7.11 DSC set-up menu options on page 144

7.1 Digital Selective Calling (DSC)

Traditional VHF radio systems require users to listen until someone speaks, and then determine whether the call is for them. DSC ensures that calls are received by alerting or announcing the intended recipient(s) first so they are ready to listen to the subsequent message on the relevant channel.

DSC is part of the Global Maritime Distress and Safety System (GMDSS), a maritime communications system for emergency and distress messages and all types of routine communications such as ship-to-ship or ship-to-shore.

DSC is a digital signalling system, which operates on VHF channel 70. DSC calls include other data such as your vessel's identification number, purpose of the call, your position and the channel you want to speak on.

DSC calls can be divided into 4 categories and are prioritized as shown below:

1. Distress
2. Urgency
3. Safety
4. Routine

Distress

A Distress call should only be used when there is imminent danger to a vehicle or person that requires immediate assistance.

When making a distress call the following information is transmitted to all stations within range:

- Vessel MMSI number.
- Vessel position (must be input manually if no position data is available).
- Local time (must be input manually if no position data is available).
- Nature of the distress (when designated).
- Transmission frequency.

The call is automatically repeated at approximately 4 minute intervals until it is acknowledged either by a coast radio station (CRS) or a vessel within radio range. Distress calls must be followed by a MAYDAY call on priority channel 16.

Urgency

An urgency call should be used when there is danger to a vehicle or person that does not require immediate assistance.

When making an urgency call the following information is transmitted to all stations within range:

- Vessel MMSI number.
- Vessel position (must be input manually if no position data is available).
- Local time (must be input manually if no position data is available).
- Transmission frequency.

Once an urgency call is sent it must be followed with a PAN PAN voice message on channel 16 and include the necessary details.

Safety

A safety call should be used when there is an important navigational warning or meteorological forecast/broadcast. Safety alerts can also be used for communications during search and rescue operations.

When making a safety call the following information is transmitted to all stations within range:

- Vessel MMSI number.
- Vessel position (must be input manually if no position data is available).
- Local time (must be input manually if no position data is available).
- Transmission frequency.

Once a safety call is sent it must be followed with a SECURITE voice message on channel 16 and include the necessary details.

Individual (routine)

Routine calls are used for contacting other vessels, marinas, or shore stations.

Routine calls are made on channel 70 using the dedicated Maritime Mobile Service Identity (MMSI) number of the station to be contacted, selecting a VHF working channel and sending the call. Both radios automatically switch to the chosen channel for conversation.

Routine calls can also be made to groups — When groups of ships need the same information (yacht races, club rallies etc.) a special group-call identity can be used to enable restricted broadcast calls.

Note:

To transmit precise position data, the radio must be connected to a GNSS (GPS) receiver. Otherwise, regular manual position updating is required.

7.2 Distress calls

Making a designated distress call

When making a Distress call you can specify the nature of the distress, if GNSS (GPS) data is not available you must also specify your coordinates.

Note:

Your radio must have an MMSI number saved before DSC functions can be used.

From the Distress call menu: **Menu > DSC Calls > Distress calls**

1. Select a distress type from the list.
 - If your radio is receiving a valid GNSS (GPS) position then the distress type and coordinates are displayed on-screen, otherwise you will be prompted to enter your position coordinates.
2. If prompted, enter your position coordinates and local time using the **Rotary knob** or **Channel Up** and **Channel Down** buttons on a Raymic handset to enter the relevant details.
3. When complete press the **OK** button.
4. Follow the steps for 'Making a Distress Call' to transmit the distress.

Making a distress call

In an emergency you can use your unit to make an automatic DSC distress call.

With the spring loaded cover open:

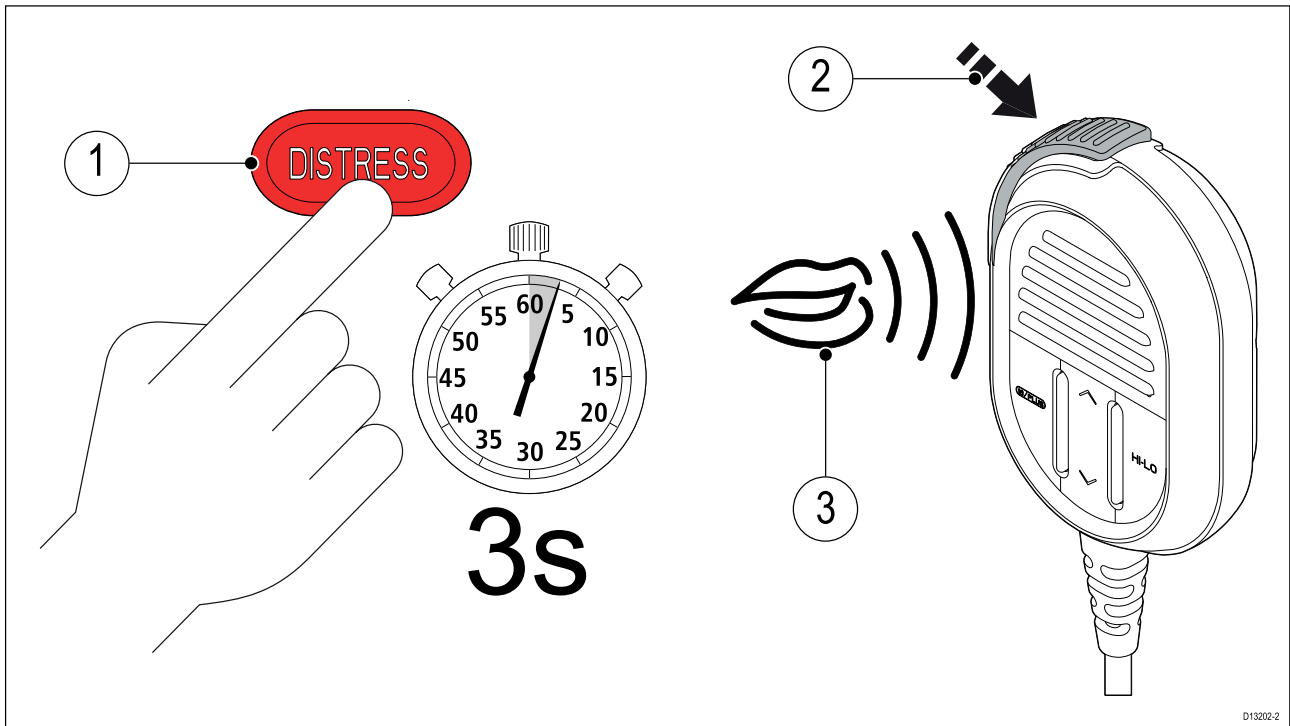

1. Press and hold the **DISTRESS** button for 3 seconds.

*Once the **DISTRESS** button is pressed a 3 second count down will begin, when the count down reaches zero the DSC distress call is transmitted.*

The distress call is repeated automatically until it is acknowledged.

2. Press and hold the **PTT** button, then slowly and clearly speak the details of the distress in the following format:

MAYDAY, MAYDAY, MAYDAY

This is <state name of vessel 3 times>

MAYDAY <state name of vessel 1 time>

My position is <state latitude and longitude, or true bearing and distance from a known point.>

I am <state nature of distress e.g. sinking, on fire etc.>

I have <state number of persons on board and any other information — drifting, flares fired etc.>

I REQUIRE IMMEDIATE ASSISTANCE

OVER

3. Release the **PTT** button.

Making a Mayday call

In an emergency you can also make a Mayday call following the instructions below.

1. Press the **16 PLUS** button.
2. Press and hold the **PTT** button.
3. Slowly and clearly speak the details of the distress:

MAYDAY, MAYDAY, MAYDAY

This is — state name of vessel 3 times

MAYDAY — state name of vessel 1 time

My position is — state latitude and longitude, or true bearing and distance from a known point

I am — state nature of distress e.g. sinking, on fire etc.

I have — state number of persons on board and any other information — drifting, flares fired etc.

I REQUIRE IMMEDIATE ASSISTANCE

OVER

4. Release the **PTT** button.
5. If an acknowledgement is not received then repeat steps 2 to 4 above.

Cancelling a distress call before transmission

To cancel a distress call before it is transmitted follow the steps below:

1. Release the **DISTRESS** button before the countdown timer completes.
When the button is released you will be returned to normal operation.

cancelling a distress call after transmission

A distress call can be cancelled after it has been transmitted.

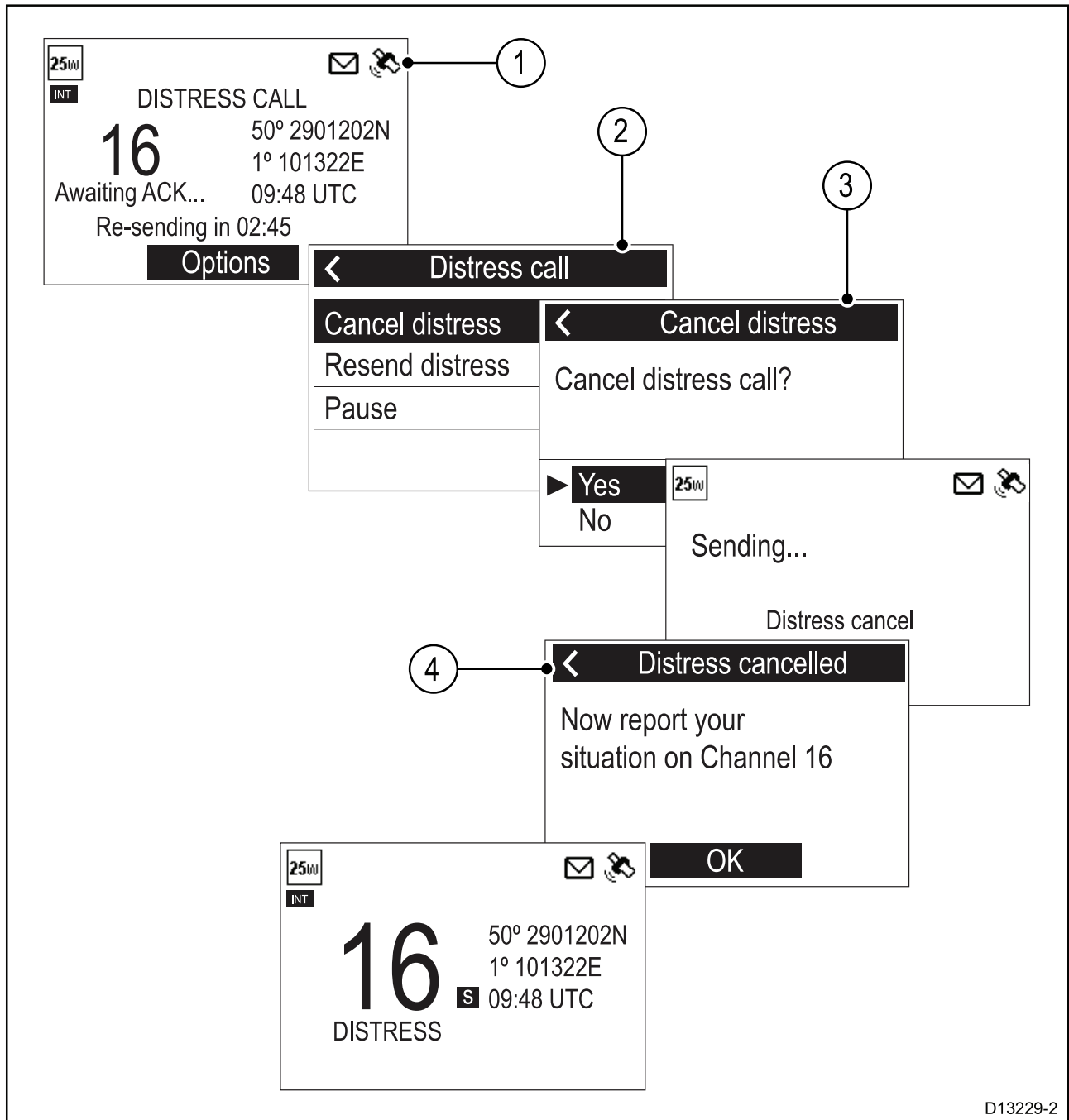

1. Select **Options**.
2. Select **Cancel distress**.
3. Select **Yes** to confirm cancellation.
4. Select **OK**.
5. Press and hold the **PTT** button and make a broadcast to all stations giving your vessel's name, call sign and MMSI number and cancel the false distress alert

Example: "All, Stations, All Stations, All Stations. This is <NAME>, <CALL SIGN>, <MMSI ID>, <POSITION>. Cancel my distress alert of <DATE>, <TIME>, <NAME>, <CALL SIGN>"

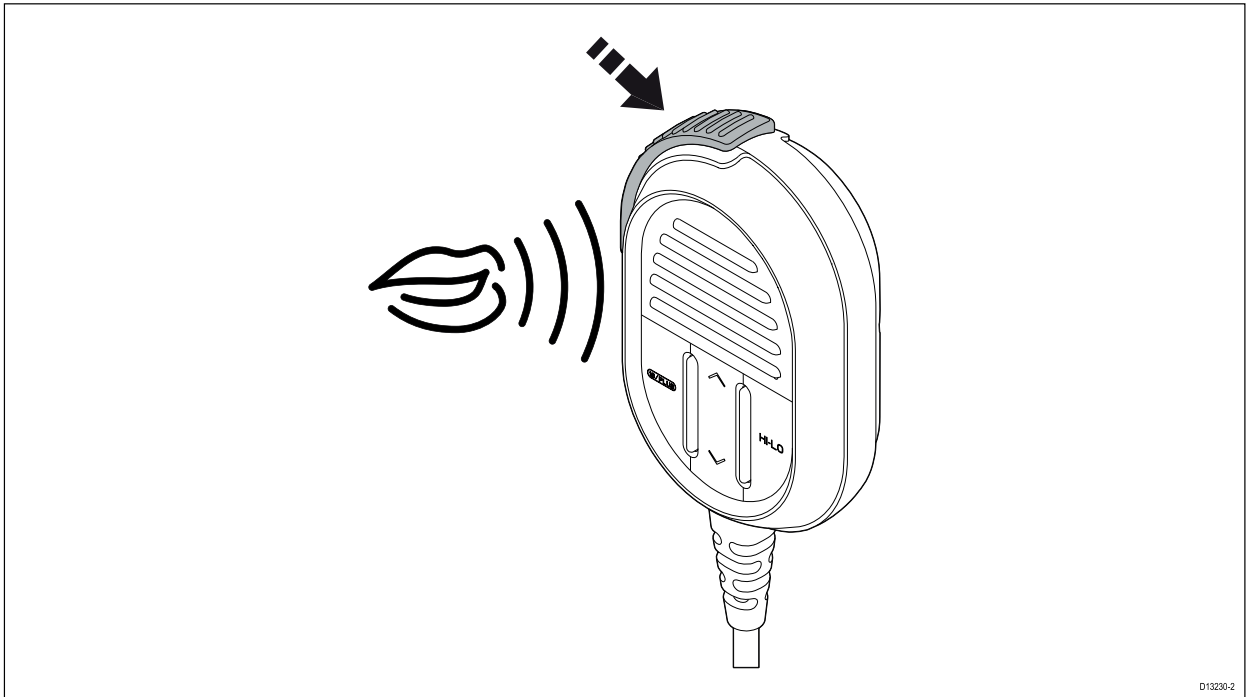

6. Repeat the broadcast described in step 5.

Receiving a distress call

It is expected that only a Coast Radio Station (CRS) will acknowledge DSC distress calls and will act as the coordinator for the rescue operation.

When a distress call is received an alarm is sounded at full volume and the LCD displays information relating to the distress.

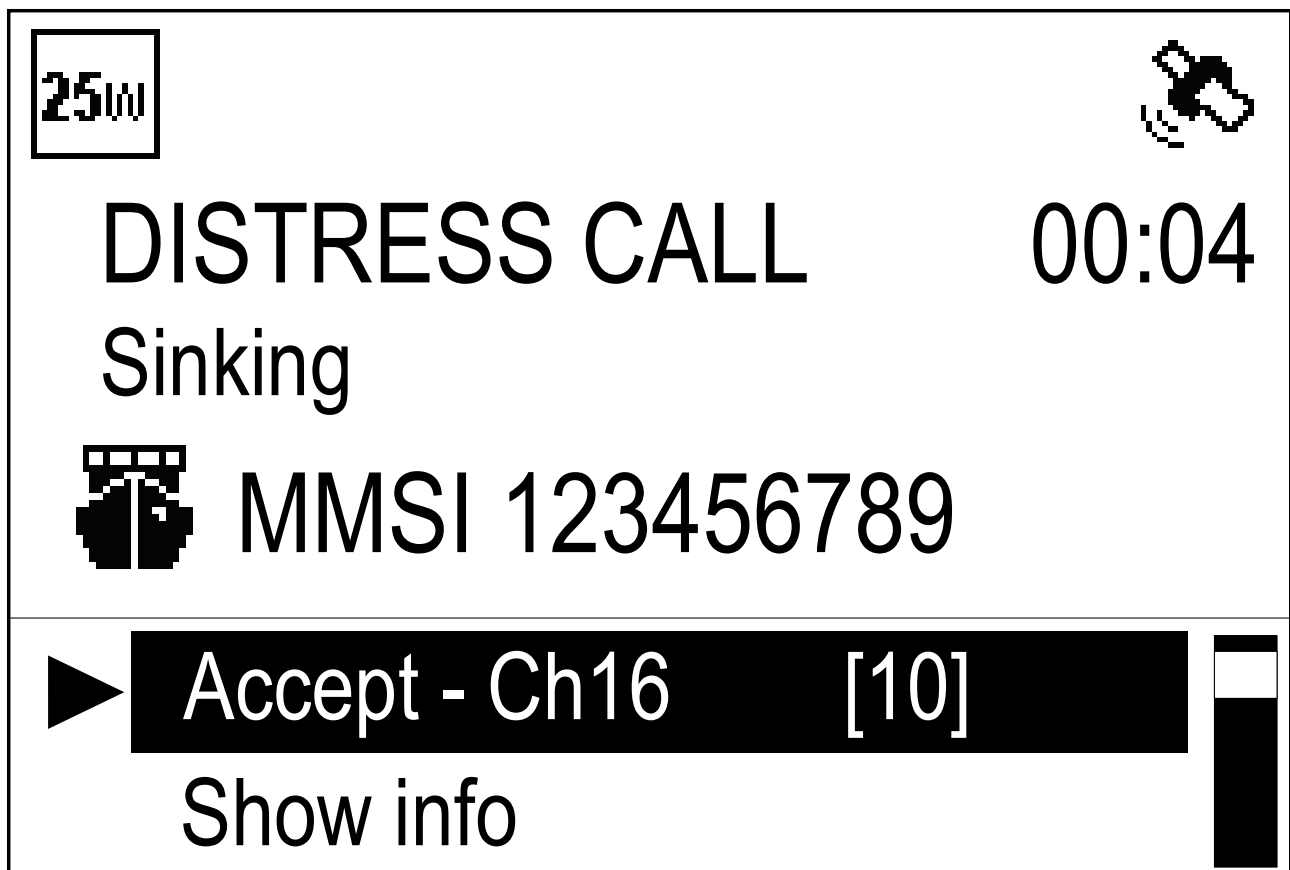

If the **Auto channel change** function is enabled; 10 seconds after receipt of a distress call the radio will automatically re-tune to channel 16. Otherwise the user is prompted to change channel manually.

The details of the distress call are recorded in the distress log and the envelope icon will flash to let you know a message has been received. When connected to a **Raymarine**® multifunction display (**MFD**) the position data from the distress call can also be displayed in the Chart application.

When the received distress call is acknowledged by the CRS or by another station the radio will resume normal operation.

Ignoring a distress call

You can ignore a distress call by muting the alarm and cancelling the distress call screen.

If your radio is already tuned to the priority channel then the **Ignore** option will not be available.

With an incoming distress call displayed.

1. Select **Ignore** from the options displayed.
Normal operation is resumed.

Acknowledging a distress call

Distress calls must only be acknowledged if the call continues without acknowledgement from a CRS, you are close enough to the distressed vessel to be of assistance and are prepared to relay the distress to a CRS by any means possible. Class D DSC radios are forbidden from automatically acknowledging distress calls. Acknowledgement must only be made by voice message on channel 16.

After receiving a distress call that has gone unanswered:

1. Switch to channel 16 to listen for the distress voice message.
2. Wait for the CRS to acknowledge the call.
3. If the distress call is not acknowledged by another station then acknowledge the call as follows:

MAYDAY

(MMSI of the vessel in distress)

Name of vessel in distress <repeated 3 times>

Call sign of the vessel in distress

This is <MMSI of your vessel>, <name of your vessel repeated 3 times> <call sign of your vessel>

RECEIVED MAYDAY

4. You **MUST** then notify the shore authorities by any means possible to relay the distress call.

Manually relaying a distress call

A distress relay should only be sent if: the person or vehicle in distress is unable to transmit the distress call itself, for example red flares sighted at night or the person or vehicle in distress is out of range of a CRS and you have already acknowledged the distress by voice message. You can also relay a received distress relay alert manually if it goes unanswered.

1. Switch to channel 16
2. Slowly and clearly speak the details of the distress:
MAYDAY RELAY, MAYDAY RELAY, MAYDAY RELAY

This is <MMSI of your vessel, name of your vessel repeated 3 times and your call sign>

Received the following MAYDAY from <MMSI of vessel in distress, name of vessel in distress, call sign of vessel in distress>

Message begins

Message received from vessel in distress or details of the distress

Message ends

OVER

Distress relays sent by other stations

When a Coast Station or another vessel, has received, and acknowledged a DSC distress alert it may transmit a distress alert relay to other vessels in the immediate area.

Distress relays sent from other stations can be received by the radio.

The radio cannot re-send a distress relay automatically. If required you can relay a distress relay message manually.

If a distress relay is sent specifically to the radio then it can be acknowledged, otherwise acknowledgement is not required.

Acknowledging a distress relay sent to your vessel

If a distress relay is specifically sent to your vessel this will be because the sender deems you to be in a position to assist in the rescue. The distress relay information is displayed onscreen.

When a distress relay is received:

1. Select **Show info** from the options to review the relevant details.
2. If the distress relay was sent individually to you, select **Accept** to send a distress relay acknowledgement.
3. Ensure the radio is tuned to channel 16.

Note: Distress relay calls can only be acknowledged automatically when sent individually to you.

7.3 Urgency calls

Making an urgency call

An urgency call should be used when there is danger to a vehicle or person that does not require immediate assistance. Urgency calls are transmitted to all stations.

From the **All ships call** menu: **Menu > DSC Calls > All ships call**.

1. Select **Urgency**.
2. Select the channel for subsequent communication.
The call is transmitted. Once the call has been successfully transmitted '**Sent**' is displayed onscreen and the channel is changed to the specified channel.
3. Press the **OK** button.
4. Press and hold the **PTT** button and speak the following message:

PAN PAN, PAN PAN, PAN PAN

ALL STATIONS, ALL STATIONS, ALL STATIONS

This is — MMSI of your vessel, name of your vessel repeated 3 times, call sign of your vessel.

Position — Your vessel's position.

Reason for call — State the reason for the call and include all information which will assist in the rescue.

OVER

Receiving an urgency call

When an urgency call is received:

1. Select **Show info** from the options to review relevant call details.
2. Select **Accept** at any time to accept the call.

If auto channel change is turned on then the channel will automatically change after 10 seconds.

The radio is re-tuned to the specified channel.

3. Listen for the urgency call message.

7.4 Safety calls

Making a safety call

Safety calls should be used when there is an important navigational warning or meteorological forecast/broadcast. Safety alerts can also be used for communications during search and rescue operations.

From the **All ships call** menu: **Menu > DSC Calls > All ships call**.

1. Select **Safety**.
2. Select the channel for subsequent communication.
The call is transmitted. Once the call has been successfully transmitted '**Sent**' is displayed onscreen and the channel is changed to the specified channel.
3. Press the **OK** button.
4. Press and hold the **PTT** button and speak the following message:

SECURITE, SECURITE, SECURITE

ALL STATIONS, ALL STATIONS, ALL STATIONS

This is — MMSI of your vessel, name of your vessel repeated 3 times, call sign of your vessel.

Position — Your vessel's position.

Reason for call — state the reason for the safety call.

OUT

Receiving a safety call

When a safety call is received:

1. Select **Show info** from the options to review relevant call details.
2. Select **Accept** at any time to accept the call.

If auto channel change is turned on then the channel will automatically change after 10 seconds.

The radio is re-tuned to the specified channel.

3. Listen for the safety call message.

7.5 Individual (routine) calls

Individual calls can be made to contacts saved in your Phonebook or to any station by manually entering an MMSI number.

Note:

When calling a coast station there is no need to select a channel for communication.

If a call cannot be accepted then a reason code is displayed.

| | |
|-------------|-----------------------------------------|
| No Reason | No reason given |
| Congestion | Congestion at maritime switching centre |
| Busy | Station Busy |
| Queue | Queue indication |
| Barred | Station barred |
| No operator | No operator available |
| Unavailable | Operator temporarily unavailable |
| Disable | Equipment disabled |
| Unable Ch | Unable to use proposed channel |
| Unable mode | Unable to use proposed mode |

Making an Individual call

From the **Individual Call** menu: **Menu > DSC Calls > Individual Call**.

1. Select **Phonebook** to make a routine call to a contact saved in your Phonebook, or
2. Select **Recent Calls** to make a routine call to a contact that you have called recently, or
3. Select **Enter MMSI** to manually enter the MMSI number of the station you want to contact.
4. Select a contact or enter an MMSI manually and press the **OK** button.
5. Select the Channel you want to transmit the call on.

If the MMSI is a CSR then the radio will automatically tune to the correct Channel. The radio will wait for an acknowledgement to be received.

6. If an acknowledgement is received, press the **OK** button.
7. Press and hold the **PTT** button and speak your message.
8. Release the **PTT** button when you have completed your message.

Receiving an Individual call

With an incoming individual call displayed:

1. Select **Show info** from the options to review relevant call details.
2. Select **Reply on Ch ##** at any time to accept the call.

If auto channel change is turned on then the channel will automatically change after 10 seconds.

The radio is re-tuned to the specified channel.

3. To reject the call, select **Reject**.
4. If you rejected the call, select a reason for the rejection from the list.

Confirmation of the acceptance or rejection of the call is displayed. If you have accepted the call then the radio will re-tune to the requested channel.

7.6 Group calls

Group calls can be made to groups of vessels sharing the same Group MMSI numbers.

Group calls are made by selecting a saved group contact from the **Phonebook** or by entering the Group MMSI number for the group you want to call.

Making a group call

From the **Group Call** menu: **Menu > DSC Calls > Group Call**.

1. Select **Phonebook** to make a call to a group saved in your Phonebook, or
2. Select **Recent Calls** to make a call to a group that you have called recently, or
3. Select **Enter MMSI** to manually enter the MMSI number of the group you want to contact.
4. Select a group or enter an MMSI manually and press the **OK** button.
5. Select the Channel you want to transmit the call on.

The radio will wait for an acknowledgement to be received.

6. If an acknowledgement is received, press the **OK** button.
7. Press and hold the **PTT** button and speak your message.
8. Release the **PTT** button when you have completed your message.

Receiving a group call

Note:

To receive a call made to a Group, the Group's MMSI number must be saved in your Phonebook.

With an incoming group call displayed:

1. Select **Show info** from the options to review relevant call details.
2. Select **Reply on Ch ##** at any time to accept the call.

If auto channel change is turned on then the channel will automatically change after 10 seconds.

The radio is re-tuned to the specified channel.

3. To reject the call, select **Reject**.
4. If you rejected the call, select a reason for the rejection from the list.

Confirmation of the acceptance or rejection of the call is displayed. If you have accepted the call then the radio will re-tune to the requested channel.

7.7 Position requests

The radio can request position information from any station capable of responding to the request.

Position requests can be sent to any contact stored in the **Phonebook** or by manually inputting the station's MMSI number.

When connected to a Raymarine® multifunction display (MFD) the position data from the request can also be display in the Chart app.

Making a position request

You can request the position of another station.

From the **Position Request** menu: **Menu > DSC Calls > Position Request**.

1. Select **Phonebook** to request the position of a contact saved in your Phonebook, or
2. Select **Recent Calls** to request the position of a contact that you have called recently, or
3. Select **Enter MMSI** to manually enter the MMSI number of the station that you want to request the position of.
4. Select a contact or enter an MMSI manually and press the **OK** button.

The position request is sent. When a response is received the position of the contact is displayed.

Responding to a position request

With a Position request displayed:

1. Select **Send position** to respond with your current location, or
2. Select **Cancel** to ignore the request.
3. If the position reply is set to manual then select **SEND** to send the position report.
4. Select **OK** to resume normal operation.

If the **Position requests** setting, found in the **GPS set-up** menu is set to **Auto accept** then the response is sent automatically.

Setting automatic response to position requests

You can configure your radio to respond to incoming position requests automatically.

From the **DSC set-up** menu: **Menu > Set-up > DSC set-up**

1. Select **Position requests** to switch between Manual accept (default) and Auto accept.

7.8 Phonebook

The Phonebook can be used to save up to 100 contacts.

You can add, edit and delete contacts stored in the Phonebook.

Adding a Phonebook entry

You can save contacts in the Phonebook by entering their MMSI and assigning a name to the contact.

From the **DSC Calls** menu: **Menu > DSC Calls**.

1. Select **Phonebook**.
2. Select **Add new**.
3. Select the type of contact.
 - Vessel
 - Group
 - Coast station
4. Use the **Rotary knob** or the **Channel Up** and **Channel Down** buttons on a Raymic handset to cycle through the available numbers and press **OK** to confirm and move to the next digit.
5. Press the **OK** button to confirm the MMSI.
6. Use the **Rotary knob** or the **Channel Up** and **Channel Down** buttons on a Raymic handset to cycle through the available characters and press **OK** to confirm and move to the next character.

The maximum length for contact names is 10 characters.

7. If the Contact name is less than 10 characters, press and hold the **OK** button and select **Save**.
8. Press the **Back** button at any time to edit characters you have already entered.
9. Press and hold the **OK** button and select **Move cursor** to edit an existing character.
10. When complete press the **OK** button to return to the Phonebook.

Editing a Phonebook entry

From the **DSC Calls** menu: **Menu > DSC Calls**.

1. Select **Phonebook**.
2. Select the contact you want to edit.
3. Select **Edit name** or **Edit MMSI**
The contact's MMSI or name is displayed.
4. Use the **Rotary knob** or the **Channel Up** and **Channel Down** buttons on a Raymic handset to change a character.
5. Press the **OK** button to confirm each character and move to the next.
6. When you have completed your changes press the **OK** button again to save the changes.

Deleting a Phonebook entry

From the **DSC Calls** menu: **Menu > DSC Calls**.

1. Select **Phonebook**.
2. Select the contact you want to edit.
3. Select **Delete**.
4. Select **Yes**.

The contact is deleted.

7.9 Call logs

All DSC calls are logged.

The following call types are recorded in call logs:

- distress
- distress relay
- distress acknowledgements
- sent position requests
- received position requests
- group calls
- all ship calls
- individual (routine) calls

The details below are recorded for each call:

- MMSI number(s) (If a call is relayed up to 3 MMSI numbers can be recorded)
- type of call
- date and time of call
- latitude and longitude (if sent with the call)
- nature of distress (specified distress calls only)

If the call was received from a contact in the Phonebook then the contact name is displayed, otherwise the MMSI number is displayed.

Accessing the call logs

Follow the steps below to access the call logs.

From the **DSC Calls** menu: **Menu > DSC Calls**.

1. Select **Call logs**.
2. Select the log you want to view:
 - Unread
 - Distress calls
 - Non-distress calls
 - Outgoing calls
 - Position log
3. Select a call and press the **OK** button to view details.
4. Select **Options** to view available options.
 - **Call Back** — return a received call.
 - **Resend** — only available in the outgoing call log.
 - **Call** — available in the position log.
 - **Send position** — available in the position log.
 - **Request position** — available for individual and distress calls.
 - **Save to Phonebook** — available for received and outgoing calls to new contacts.
 - **Send ACK** — available for unacknowledged individual received calls.
 - **Delete** — deletes the log entry.

7.10 Test calls

A Test Call feature is available for the purposes of testing your DSC VHF radio for correct operation.

There are 2 types of test call:

- Test call to the US Coast Guard automated response test call service (MMSI: **003669999**). This type of test call will receive an automated response (acknowledgement).
- Test call to another vessel that has a radio that supports the test call feature. Your radio will automatically acknowledge test calls received from other radios.

For radios that do NOT support the test call feature, correct radio operation can be tested by making an Individual call on channel 70 to another DSC VHF radio.

It is recommended that once you've successfully placed a test call you add the test call MMSI to your radio's Phonebook for easy retrieval for future test calls. For information on how to add an MMSI to your radio's Phonebook, refer to the "Adding a Phonebook entry" section.

Note:

Individual calls (that is, NOT a test call) to the US Coast Guard 003669999 MMSI will NOT receive an automated response.

Note:

The US Coast Guard automated response test call service is only available in the United States and its coastal waters.

Making a Test call

From the **Test call** menu: **Menu > DSC Calls > Test call**.

1. Select **Phonebook** to make a test call to a contact saved in your Phonebook, or
2. Select **Recent Calls** to make a test call to a contact that you have called recently, or
3. Select **Enter MMSI** to manually enter the MMSI number of the station you want to send a test call.
4. Select a contact or enter an MMSI manually and press the **OK** button.

The test call is sent.

5. If you called the US Coast Guard automated response test call MMSI (003669999), wait for an acknowledgement. If you made a test call to another vessel with a test call capable radio, your radio will wait for a response.

When an acknowledgement is received, an audible alarm is sounded and the message (envelope) icon is displayed.

Receiving a test call

Your radio will automatically acknowledge received Test calls from other stations

When a Test call is received a notification is displayed to alert you that a test call has been received and automatically acknowledged.

7.11 DSC set-up menu options

The DSC set-up menu options can be accessed from the following menus:

- **Menu > DSC Calls > DSC set-up**
- **Menu > Set-up > DSC set-up**

| Menu item | Description | Options |
|----------------------------|--------------------------------------------------------------------------------------------------------------------------------------------------------|-------------------------------------------------------------------------------------------------|
| MMSI | To enable the DSC functions on your radio you must enter your unique MMSI number. | |
| Auto channel change | When automatic channel change is turned on the radio will automatically re-tune after 10 seconds to the requested channel when DSC calls are received. | <ul style="list-style-type: none">• On (default)• Off |
| Position requests | With Position requests set to Auto accept the radio will automatically send out position details when a position request is received. | <ul style="list-style-type: none">• Auto accept (default)• Manual accept |

Chapter 8: VHF operations

Chapter contents

- 8.1 Watch modes on page 146
- 8.2 Scan Mode on page 147
- 8.3 Priority channels on page 148
- 8.4 Sensitivity on page 149
- 8.5 Private channels on page 150
- 8.6 Automatic Transmitter Identification System (ATIS) and Marcom-C mode on page 151
- 8.7 AIS receiver on page 152
- 8.8 Set-up menu options on page 153

8.1 Watch modes

Watch mode monitors priority channels and the currently selected channel.

There are 2 types of watch mode; **Dual watch** and **Triple watch** or **Tri watch**.

- **Dual watch** — This mode monitors priority channel 16 and the currently selected channel.
- **Triple watch** — This mode monitors priority channel 16, the second priority channel (Channel 09 (default)) and the currently selected channel. The second priority channel can also be set to a user defined channel.

When the radio detects a transmission, Watch mode is suspended until the transmission ends; watch mode will then recommence.

Setting Watch mode

From the **Watch Mode** menu: **Menu > Watch Mode**.

1. Select **Dual Watch** or **Triple Watch** as required.
The radio is now in Watch mode.
2. Select **2nd priority channel** to select a different second priority channel for Triple watch.
3. During Watch mode, press the **Back** button at any time to end the Watch mode and resume normal operation.

8.2 Scan Mode

Scan mode enables automatic searching for channels that are currently broadcasting.

Scan mode will search through available channels and stop when it finds a channel that is currently broadcasting. If the broadcast stops or is lost for more than 5 seconds then the scan will resume.

Channels can be temporarily removed from an active scan, and the direction of scan can also be changed. When the scan reaches the last channel in the band the scan cycle is repeated.

The following scans options are available:

- **All Channels** — All channels in the frequency band the radio is set to are scanned in sequence.
- **All Channels + 16** — All channels in the frequency band the radio is set to are scanned, after each channel is scanned priority channel 16 is scanned.
- **Saved Channels** — Only channels saved to the radio's memory are scanned in sequence.
- **Saved Channels + 16** — Only channels saved to the radio's memory are scanned, after each channel is scanned priority channel 16 is scanned.

Note:

If the weather alert function is activated, the weather alert channel is included in the scan.

Setting Scan mode

Scan mode is started from the main menu.

From the **Scan Mode** menu: **Menu > Scan Mode**.

1. Select the relevant Scan mode.
The radio is now in Scan mode.
2. Select **Edit Saved Channels** to select the channels that will be scanned when performing a Saved channel scan.
3. During Scan mode, press the **Back** button at any time to end the Scan mode and resume normal operation.

8.3 Priority channels

Channel 16 is the dedicated priority channel.

The default secondary priority channel is channel 09. The second priority channel can be changed if desired.

Switching between priority channels

1. Press the **16 / +** button to switch between priority channels.

Setting a second priority channel

You can select which channel you want to use as the second priority channel.

From the **Channel set-up** menu: **Menu > Set-up > Channel set-up**.

1. Select **2nd priority channel**.
2. Select the channel that you want to assign as the second priority channel.

8.4 Sensitivity

The sensitivity level of the radio can be set to Local mode or Distant mode.

Local mode decreases the receiver sensitivity in high traffic areas to reduce unwanted reception. When in Local mode the 'Loc' icon is displayed in the status bar.

Distant mode sets the receiver sensitivity to full.

Switching sensitivity modes

You can switch between Local and Distant modes at any time.

From the **Set-up** menu: **Menu > Set-up**.

1. Select **Sensitivity**.

Selecting Sensitivity will switch between Local mode and Distant mode (default).

8.5 Private channels

The radio may be able to receive additional Private channels depending on the country it is used in and whether the appropriate licenses are held.

The following Private channel sets can be selected:

- None
- Belgium
- Denmark (pleasure)
- Denmark (fishing)
- Finland (pleasure)
- Finland (fishing)
- Holland (Netherlands)
- Norway (pleasure)
- Norway (fishing)
- Sweden (pleasure)
- Sweden (fishing)
- UK

Selecting a private channel set

You can select the set of private channels you want to use.

From the **Channel set-up** menu: **Menu > Set-up > Channel set-up**.

1. Select **Private channels**.

The list of private channel sets is displayed:

2. Select the required private channel set.

8.6 Automatic Transmitter Identification System (ATIS) and Marcom-C mode

ATIS is a European system used on some inland waterways.

VHF radios operating in an ATIS region must be programmed with a unique ATIS number; this can be obtained from the relevant licensing authority. The ATIS number is attached as a digital signal at the end of each transmission and identifies you to the relevant authorities who monitor the system.

When operating in ATIS mode, some of the products features are not available:

- Use of DSC functions is not permitted in ATIS regions.
- Watch modes are not permitted in ATIS regions.
- Channel scanning is not permitted in ATIS regions.
- ATIS regulations restrict the transmit power to 1 watt for the following channels: 6, 8, 10, 11, 12, 13, 14, 71, 72, 74 and 77.

You can enable or disable ATIS using the menus (except on Marcom-C configured units).

Marcom-C mode

Marcom-C mode is a restricted radio configuration for VHF operators with a Marcom-C license. This is applicable to radios operated exclusively in European inland waterways using the ATIS system.

A Marcom-C VHF radio has the ATIS permanently enabled. You will not be able to disable ATIS operation. Marcom-C operation is set by the dealer at point of sale. If you wish to enable or disable Marcom-C mode, you must contact your Raymarine dealer.

For further information please contact Raymarine technical support.

Enabling and disabling ATIS mode

ATIS is a European system used on some inland waterways. A unique ATIS ID must be entered before ATIS mode can be enabled.

With ATIS mode enabled the radio's region will be fixed to the INT (international) frequency band and the following functions are disabled:

- DSC functions
- Watch Mode
- Scan Mode
- High/low power is restricted on certain channels

From the Main menu.

1. Select **Set-up**.
2. Select **ATIS set-up**.
3. Select **ATIS**.

If no ATIS ID has been set then you will be requested to enter one before ATIS mode is enabled.

4. If an ATIS ID has already been set then select **On** to enable ATIS mode or **Off** to disable ATIS mode.

8.7 AIS receiver

Depending on variant your radio may have a built-in AIS receiver.

With the built-in AIS receiver switched on AIS information can be sent to a connected Raymarine® MFD using either NMEA 0183 or SeaTalkng®.

Note: If using the built-in AIS receiver and outputting over NMEA 0183, ensure that the baud rate is set to **0183 High speed: Menu > Set-up > Network output** .

Switching AIS on and off

From the **Set-up** menu: **Menu > Set-up**.

1. Select **AIS**.

Selecting AIS will switch the internal AIS receiver On and Off.

8.8 Set-up menu options

The Set-up menu options can be accessed from the Main menu.

| Menu | Description | Options |
|------------------------------|----------------------------------------------------------------------------------------------------------------------------------------------------------------------------------------------------------------------------------------------------|-------------------------------------------------------------------------------------------------------------------------------------------------------------------------------------------|
| Display set-up | Provides access to the display settings menu. | <ul style="list-style-type: none"> • Backlight • Shared brightness • Contrast • Homescreen display |
| Language | Enables selection of the user interface language. | <ul style="list-style-type: none"> • English — English • Español — Spanish • Français — French • Deutsch — German • Italiano — Italian |
| Units | Provides access to units of measure selection settings. | <ul style="list-style-type: none"> • Time format • Time offset • Bearing mode • Speed unit |
| Power output | Switches the Power output of the radio. | <ul style="list-style-type: none"> • Distant (default) • Local |
| Sensitivity | Switches the Sensitivity of the radio. | <ul style="list-style-type: none"> • Low • High (default) |
| Noise cancelling (Tx) | Switches the transmission noise cancellation feature On and Off. <div style="border: 1px solid black; padding: 5px; margin-top: 10px;"> <p>Note: Menu only available on Ray63 and Ray73.</p> </div> | <ul style="list-style-type: none"> • On (default) • Off |
| Wireless set-up | Provides access to settings which apply to wireless devices. <div style="border: 1px solid black; padding: 5px; margin-top: 10px;"> <p>Note: Menu only available on Ray63 and Ray73 when a Wireless hub is connected.</p> </div> | <ul style="list-style-type: none"> • Wireless hub set-up • Wireless hub • Wireless speaker |
| Key Beep | Enables adjustment of the beep which is heard when pressing buttons. | <ul style="list-style-type: none"> • Off • Quiet (default) • Loud |
| Channel set-up | Provides access to the Channel set-up menu. | <ul style="list-style-type: none"> • Channel name • 2nd priority channel • Private channels • Frequency band |

| Menu | Description | Options |
|-----------------------|----------------------------------------------------------------------------------------------------------------------------------------------------------------------------------------------|------------------------------------------------------------------------------------------------------------------------------------------------------------------------------------|
| GPS set-up | Provides access to the GPS set-up menu. | <ul style="list-style-type: none"> • Internal GPS • Homescreen display • Bearing mode • Position requests • Set manual position |
| DSC set-up | Provides access to the DSC set-up menu. | <ul style="list-style-type: none"> • MMSI • Auto channel change • Position requests |
| AIS | Switches the internal AIS receiver on and off on. <div style="border: 1px solid black; padding: 5px; margin-top: 10px;"> <p>Note: Menu only available on the Ray73.</p> </div> | <ul style="list-style-type: none"> • Off (default) • On |
| Network output | Enables you to select the network to be used to output and receive data. | <ul style="list-style-type: none"> • NMEA 2000 • 0183 High speed • 0183 Std speed |
| ATIS set-up | Enables you to switch ATIS mode on and off and enter your ATIS ID. | <ul style="list-style-type: none"> • ATIS • ATIS ID |
| Maintenance | Enables you to view system details and functions that may be required during maintenance and troubleshooting. | <ul style="list-style-type: none"> • About this unit • System reset • System test |

Display Set-up menu

The following menu options are available form the Display Set-up menu.

| Menu | Description | Options |
|---------------------------|-------------------------------------------------------------|-----------------------------------------------------------------------------------------------------------|
| Backlight | Increases and decreases the LCD and button backlight level. | <ul style="list-style-type: none"> • 0 to 9 • Off |
| Shared brightness | Enables set-up of Shared Brightness. | <ul style="list-style-type: none"> • Shared brightness • Group |
| Contrast | Increases and decreases the LCD Contrast level. | <ul style="list-style-type: none"> • 0 to 10 |
| Homescreen display | Determines the details displayed onscreen. | <ul style="list-style-type: none"> • Location & Time • Location & COG/SOG |

Shared Brightness menu

The following menu options are available form the Shared Brightness menu.

| Menu | Description | Options |
|--------------------------|---------------------------------------------------------------|-------------------------------------------------------------------------------------------------|
| Shared brightness | Enables and disables Shared Brightness. | <ul style="list-style-type: none"> • On • Off |
| Group | Enables you to assign the radio to a Shared Brightness group. | <ul style="list-style-type: none"> • Helm 1 • Helm 2 • Cockpit |

| Menu | Description | Options |
|------|-------------|---------------------------------------------------------------------------------------------------------|
| | | <ul style="list-style-type: none">• Flybridge• Mast• Group 1 to Group 5 |

Chapter 9: Hailer, Fog horn, and Intercom

Chapter contents

- [9.1 Hailer Fog Intercom menu on page 158](#)
- [9.2 Loud hailer on page 159](#)
- [9.3 Fog horn on page 160](#)
- [9.4 Intercom on page 161](#)

9.1 Hailer Fog Intercom menu

The menu options available are determined by the accessories connected to your radio.

| Menu name | Connected devices |
|--------------|-------------------------------------------|
| Hail/Fog/Int | Loud hailer and second station connected. |
| Hailer/Fog | Loud hailer connected, no second station |
| Intercom | Second station connected, no loud hailer |

Note:

For simplicity the procedures in this section all refer to the **Hail/Fog/Int** menu.

9.2 Loud hailer

The Ray70, Ray73, Ray90 and Ray91 VHF Radios can be connected to a Loud hailer.

In hailer mode anything spoken into the handset is amplified and broadcast from the hailer. The message is not transmitted over VHF/DSC.

When the hailer is active VHF calls cannot be sent or received.

Using the hailer

From the **Hail/Fog/Int** menu: **Menu > Hail/Fog/Int**.

1. Select **Hailer**.
Hailer mode is now active
2. Press and hold the **PTT** button.
3. Speak your message.
4. Release the **PTT** button.
5. Press the **Back** button to exit Hailer mode.
6. The hailer listening volume can be adjusted at any time in Listening mode using the **Volume Control**.
7. The hailer talking volume can be adjusted at any time, with the **PTT** button pressed using the **Volume Control**.

9.3 Fog horn

The fog horn function requires an optional loud hailer to be connected. Please check your product description to ensure a loud hailer can be connected.

The fog horn function can be set to manual or to predefined automatic modes.

In manual mode a continuous tone is sounded for as long as the **PTT** button is pressed.

In automatic mode the selected tone will repeat every 2 minutes until interrupted or cancelled. In automatic mode the radio can be used as normal between the fog horn patterns.

| Fog mode | Description | Pattern |
|-------------------------|------------------------------------------------------------|----------------------------------------------------|
| Underway | Vessel underway | 1 long tone |
| Underway/Stopped | Vessel not underway | 2 long tones |
| Sailing/Fishing | sailing vessel or any vessel fishing but not trolling | 1 long tone and 2 short tones |
| Restrict/Tow | Restricted in ability to maneuver or towing another vessel | 1 long tone and 2 short tones |
| Under tow | This vessel is being towed | 1 long tone and 3 short tones |
| Pilot vessel | This vessel is a pilot vessel | 4 short tones |
| At anchor | Vessel is at anchor | 12 consecutive rings |
| Aground | Vessel is aground | 3 short rings, 12 consecutive rings, 3 short rings |

Using the fog horn in manual mode

From the **Hail/Fog/Int** menu: **Menu > Hail/Fog/Int**.

1. Select **Fog horn**.
2. Select **Manual mode**.
3. Press and hold the **PTT** button to sound a continuous fog horn tone.
4. Press the **Back** button to exit Fog horn mode.

Using automatic fog horn modes

From the **Hail/Fog/Int** menu: **Menu > Hail/Fog/Int**.

1. Select **Fog horn**.
2. Select **Automatic mode**.
3. Select an automatic pattern.
The selected pattern will play and repeat until interrupted.
4. Select **Stop fog horn** to exit the automatic fog horn mode, or
5. Select **Change pattern** to select a different fog horn pattern.
6. To continue using the radio whilst in automatic fog horn mode select **Back** 4 times to return to the Homescreen.

You can now continue to use the radio as normal. The fog horn pattern will continue to repeat every 2 minutes. If you are making a call when it is due to sound the fog horn will be suspended until you finish your call.

Switching off Fog Horn mode

Automatic Fog Horn mode will remain active until switched off.

From the **Hail/Fog/Int** menu: **Menu > Hail/Fog/Int**.

1. Select **Fog horn**.
2. Select **Stop fog horn** to switch off the automatic fog horn mode

9.4 Intercom

The Intercom function is available when more than 1 station is connected to your radio.

The intercom function allows voice communication between handset stations. Calls can be initiated from either station.

Using the intercom

From the **Hail/Fog/Int** menu: **Menu > Hail/Fog/Int**.

1. Select **Intercom**.
2. ⁽¹⁾Select the handset you want to call.
The selected handset will ring.
3. Wait for the handset station to acknowledge the call.
4. Press and hold the **PTT** button and speak your message.

Note:

⁽¹⁾Step not required when only 2 handsets are connected.

Responding to the intercom

1. Press the **PTT** button and acknowledge the call and to respond to subsequent voice messages.

Chapter 10: Maintenance

Chapter contents

- [10.1 Maintenance on page 164](#)

10.1 Maintenance

This product has no user serviceable parts or adjustments. Never remove the cover or attempt to service the product, doing so may invalidate your product warranty.

The following preventive measures should be followed:

- Although the product is waterproof, keep the unit as dry as possible.
- If you remove a connection ensure a dust cap is fitted to the connector.

Routine checks

The following periodic checks should be made:

- Examine cables for signs of damage, such as chafing, cuts or nicks.
- Check that the cable connectors are firmly attached and that their locking mechanisms are properly engaged.

Note: Cable checks should be carried out with the power supply switched off.

Caution: Product cleaning

When cleaning products:

- Lightly rinse or flush with clean, cool fresh water.
- If your product has a display screen, do NOT wipe the screen with a dry cloth, as this could scratch the screen coating.
- Do NOT use: abrasive, acidic, ammonia, solvent or chemical based cleaning products.
- Do NOT use a jet wash.

Unit cleaning instructions

The unit does not require regular cleaning. However, if you find it necessary to clean the unit, please follow the steps below:

1. Ensure power is switched off.
2. Wipe unit clean with a damp cloth.
3. If necessary, use a mild detergent solution to remove grease marks.

Chapter 11: Troubleshooting

Chapter contents

- [11.1 Troubleshooting on page 166](#)
- [11.2 Power up troubleshooting on page 167](#)
- [11.3 VHF Radio troubleshooting on page 169](#)
- [11.4 GNSS \(GPS\) troubleshooting on page 170](#)

11.1 Troubleshooting

The troubleshooting information provides possible causes and corrective action required for common problems associated with installation and operation of your product.

Before packing and shipping, all Raymarine products are subjected to comprehensive testing and quality assurance programs. If you do experience problems with your product this section will help you to diagnose and correct problems in order to restore normal operation.

If after referring to this section you are still having problems with your product, please refer to the Technical support section of this manual for useful links and Raymarine Product Support contact details.

Performing a system reset

Note: Performing a reset will not reset MMSI and ATIS ID number.

From the Maintenance menu: **Menu > Set-up > Maintenance.**

1. Select **System reset**.
2. Select **Yes**.

The system is now reset to factory defaults.

Note: Performing the reset will delete all contacts in your phonebook and reset all user options.

System test

The system test menu can be used to show the status of the system and connected devices.

The System test menu show the status of the following system components and connected devices:

- GPS
- DSC
- Battery
- Hailer
- Remote handset
- **OK** is displayed next to each item that is either connected or enabled
- **No** is displayed next to items that are either not connected or disabled.

Checking for RF interference

If you suspect a device may be causing radio frequency (RF) interference you can use your VHF radio to check.

1. Turn off the suspect device.
2. Tune your VHF radio to a quiet channel such as Channel 13.
3. Adjust your radio's Squelch control until the radio outputs audio noise.
4. Re-adjust your radio's Squelch control until the audio is quiet, only slightly above the noise threshold.
5. Turn on the suspect device.
 - If the radio's audio noise increases then the device is causing RF interference.
 - If there is no change in the radio's audio noise then the device is not causing RF interference.

Note: If RF interference is present then it is likely that both VHF and AIS reception are being degraded by the device.

11.2 Power up troubleshooting

Problems at power up and their possible causes and solutions are described here.

Product does not turn on or keeps turning off

| Possible causes | Possible solutions |
|------------------------------------------------------------|-----------------------------------------------------------------------------------------------------------------------------------------------------------------------------------------------------------------------------------------------------------------------------------------------------------------------------------------------------------------------------------------------------------------------------------------------------------------------------------------------------------------------------------------------------------------------------------------------------------------------------------------------------------------------------------------------------------------------------------------------------------------------------------------------------|
| Blown fuse / tripped breaker | <ol style="list-style-type: none"> 1. Check condition of relevant fuses and breakers and connections, replace if necessary (Refer to Chapter 13 Technical specification for fuse ratings.) 2. If fuse keeps blowing check for cable damage, broken connector pins or incorrect wiring. |
| Poor / damaged / insecure power supply cable / connections | <ol style="list-style-type: none"> 1. Check that the power cable connector is fully inserted into the unit and locked in position. 2. Check the power supply cable and connectors for signs of damage or corrosion, replace if necessary. 3. With the unit turned on, try flexing the power cable near to the display connector to see if this causes the unit to re-boot/lose power, replace if necessary. 4. Check the vessel's battery voltage, the condition of the battery terminals and power supply cables, ensuring connections are secure, clean and free from corrosion, replace if necessary. 5. With the product under load, using a multi-meter, check for high voltage drop across all connectors/fuses etc, replace if necessary. |
| Incorrect power connection | The power supply may be wired incorrectly, ensure the installation instructions have been followed. (Refer to Chapter 4 Cables and connections for cable and connection requirements.) |
| Power source insufficient | With the product under load, using a multi-meter, check the power supply voltage as close to the unit as possible to establish actual voltage when the current is flowing. (Refer to Chapter 13 Technical specification for power supply requirements.) |

Product will not boot up (re-boot loop)

| Possible causes | Possible solutions |
|-----------------------------|----------------------------------------------------------------------------------------------------------------------------------------------|
| Power supply and connection | See possible solutions from 'Products does not turn on or keeps turning off' above. |
| Software corruption | In the unlikely event that the products software has become corrupted please try re-flashing the latest software from the Raymarine website. |

Product does not turn on or keeps turning off

| Possible causes | Possible solutions |
|------------------------------------------------------------|--------------------------------------------------------------------------------------------------------------------------------------------------------------------------------------------------------------------------------------------------------------------------------------------------------------------------------|
| Blown fuse / tripped breaker | <ol style="list-style-type: none"> 1. Check condition of relevant fuses and breakers and connections, replace if necessary (Refer to Chapter 13 Technical specification for fuse ratings.) 2. If fuse keeps blowing check for cable damage, broken connector pins or incorrect wiring. |
| Poor / damaged / insecure power supply cable / connections | <ol style="list-style-type: none"> 1. Check that the power cable connector is fully inserted into the unit and locked in position. 2. Check the power supply cable and connectors for signs of damage or corrosion, replace if necessary. |

| Possible causes | Possible solutions |
|----------------------------|-----------------------------------------------------------------------------------------------------------------------------------------------------------------------------------------------------------------------------------------------------------------------------------------------------------------------------------------------------------------------------------------------------------------------------------------------------------------------------------------------------------------------------------------------------------------------------|
| | <ol style="list-style-type: none"> 3. With the unit turned on, try flexing the power cable near to the display connector to see if this causes the unit to re-boot/loose power, replace if necessary. 4. Check the vessel's battery voltage, the condition of the battery terminals and power supply cables, ensuring connections are secure, clean and free from corrosion, replace if necessary. 5. With the product under load, using a multi-meter, check for high voltage drop across all connectors/fuses etc, replace if necessary. |
| Incorrect power connection | The power supply may be wired incorrectly, ensure the installation instructions have been followed. (Refer to Chapter 4 Cables and connections for cable and connection requirements.) |
| Power source insufficient | With the product under load, using a multi-meter, check the power supply voltage as close to the unit as possible to establish actual voltage when the current is flowing. (Refer to Chapter 13 Technical specification for power supply requirements.) |

Wired handset will not power up

| Possible causes | Possible solutions |
|------------------------------------------------|----------------------------------------------------------------------------------------------------------------------------------------------------------------------------------------------------------------------------------------------------------------------------------------------------------------------------------------------------------------------------------|
| Handset not turned on | The Wired handset is compatible with the Ray60, Ray63, Ray70, Ray73, Ray90 and Ray91 radios. The Wired handset is supplied power from the Base station. Press the Power button located on the top of the Handset to power it on. |
| Software Base station / Handset mismatch | The Handset and Base station must both be running compatible software, refer to the ' <i>Software updates</i> ' section or the Raymarine website for details of compatible software versions: www.raymarine.com/software . |
| Poor / damaged / insecure cables / connections | <ol style="list-style-type: none"> 1. Check that the Base station is correctly powered. 2. With the Handset turned on, try flexing the cable near to the connectors to see if this causes the Handset to re-boot/loose power, replace if necessary. 3. Check cable connections are secure, clean and free from corrosion, replace if necessary. |

11.3 VHF Radio troubleshooting

Problems with your VHF radio and their possible causes and solutions are described below:

DSC functions are not available / working

| Possible Causes | Possible Solutions |
|----------------------------------------|----------------------------------------------------------------------------------------------------------------------------------------------------------------------------------------------------------------------------------------------------------------|
| MMSI number not programmed. | Programme your MMSI number. |
| Radio is set to ATIS or Marcom-C mode. | Use of DSC is not permitted when in ATIS or Marcom-C mode. You will be unable to make DSC distress and other types of digital selective call. If you are not in an ATIS region switch off ATIS mode: Menu > Set-up > ATIS set-up > ATIS. |
| Sensitivity set to Local. | With the sensitivity set to Local your reception will be limited Set Sensitivity to Distant: Menu > Set-up > Sensitivity. |

Passive speaker no alarm audio

| Possible Causes | Possible Solutions |
|--------------------------------------------------------|---------------------------------------------------------------------------------------------------------------------------------------------------------------|
| Passive speaker connected to second station connector. | Alarm audio is not available on passive speakers connected to the second station connector. Alarm audio should still be heard via the second station handset. |

11.4 GNSS (GPS) troubleshooting

Problems with the GNSS (GPS) and their possible causes and solutions are described below.

Before troubleshooting GNSS (GPS) problems, ensure your product has the latest software, by checking the Software Updates page on the Raymarine website www.raymarine.com.

No fix

| Possible causes | Possible solutions |
|------------------------------------------------------------------------|-------------------------------------------------------------------------------------------------------------------------------------------------------------------------------------------------------------------------------------------------------------------------------------------------------------------------------|
| No GNSS (GPS) receiver connected. | In order to obtain a position fix your product requires a GNSS (GPS) receiver. Your product may include an internal GNSS (GPS) receiver, if not then an external GNSS (GPS) receiver such as the RS150 is required. |
| No antenna connected to GNSS (GPS) receiver. | Depending on variant, your product may include an internal GNSS (GPS) receiver. The receiver may or may not include an internal antenna. If your product's internal GNSS (GPS) receiver does not include an internal antenna then you will need to connect an external passive antenna to the GNSS (GPS) / GA150 connection. |
| GNSS (GPS) Antenna location. | For optimum performance, external GNSS (GPS) antennas and GNSS (GPS) receivers that include an internal antenna should be mounted above decks and have a clear, unobstructed view of the sky, and not be in close proximity to any structural bulkheads or other electrical equipment or cables which may cause interference. |
| GNSS (GPS) switched off. | Ensure your internal GNSS (GPS) receiver is switched on in the relevant settings menu. |
| Geographic location or prevailing conditions preventing satellite fix. | Check periodically to see if a fix is obtained in better conditions or another geographic location. |

No position data

| Possible causes | Possible solutions |
|-----------------------------------------------|----------------------------------------------------------------------------------------------------------------------------------------------------------------------------------------------------------------------------------------------------------------------------------------------------------------------------------------------------------------------------------------------------------------------------------------------------------------------------------------------------------------------------------------------------------------------------------------------------|
| Internal receiver is switched off. | Ensure your external or internal receiver is switched on. |
| Wrong Network output selected. | Ensure the correct network type and speed is selected in the Network output menu: Menu > Set-up > Network output . |
| Poor / damaged / insecure cable / connection. | <ol style="list-style-type: none"> 1. Check that the connectors are fully inserted into the unit and locked in position. 2. Check the cables and connectors for signs of damage or corrosion, replace if necessary. 3. Check the vessel's battery voltage, the condition of the battery terminals and power supply cables, ensuring connections are secure, clean and free from corrosion, replace if necessary. 4. With the product under load, using a multi-meter, check for high voltage drop across all connectors/fuses etc, replace if necessary. |

Chapter 12: Technical support

Chapter contents

- [12.1 Raymarine product support and servicing on page 172](#)
- [12.2 Viewing product information on page 174](#)
- [12.3 Learning resources on page 175](#)

12.1 Raymarine product support and servicing

Raymarine provides a comprehensive product support service, as well as warranty, service, and repairs. You can access these services through the Raymarine website, telephone, and e-mail.

Product information

If you need to request service or support, please have the following information to hand:

- Product name.
- Product identity.
- Serial number.
- Software application version.
- System diagrams.

You can obtain this product information using the menus within your product.

Servicing and warranty

Raymarine offers dedicated service departments for warranty, service, and repairs.

Don't forget to visit the Raymarine website to register your product for extended warranty benefits: <http://www.raymarine.co.uk/display?id=788>.

| Region | Contact |
|---------------------------------------------|-------------------------------------------------------------------------------------------------------------------------------------------------------------------------|
| United Kingdom (UK), EMEA, and Asia Pacific | <ul style="list-style-type: none">• E-Mail: emea.service@raymarine.com• Tel: +44 (0)1329 246 932 |
| United States (US) | <ul style="list-style-type: none">• E-Mail: rm-usrepair@flir.com• Tel: +1 (603) 324 7900 |

Web support

Please visit the "Support" area of the Raymarine website for:

- **Manuals and Documents** — <http://www.raymarine.com/manuals>
- **FAQ / Knowledgebase** — <http://www.raymarine.com/knowledgebase>
- **Technical support forum** — <http://forum.raymarine.com>
- **Software updates** — <http://www.raymarine.com/software>

Worldwide support

| Region | Contact |
|--------------------------------------------------|----------------------------------------------------------------------------------------------------------------------------------------------------------------------------------------|
| United Kingdom (UK), EMEA, and Asia Pacific | <ul style="list-style-type: none">• E-Mail: support.uk@raymarine.com• Tel: +44 (0)1329 246 777 |
| United States (US) | <ul style="list-style-type: none">• E-Mail: support@raymarine.com• Tel: +1 (603) 324 7900 (Toll-free: +800 539 5539) |
| Australia and New Zealand (Raymarine subsidiary) | <ul style="list-style-type: none">• E-Mail: aus.support@raymarine.com• Tel: +61 2 8977 0300 |
| France (Raymarine subsidiary) | <ul style="list-style-type: none">• E-Mail: support.fr@raymarine.com• Tel: +33 (0)1 46 49 72 30 |
| Germany (Raymarine subsidiary) | <ul style="list-style-type: none">• E-Mail: support.de@raymarine.com• Tel: +49 (0)40 237 808 0 |
| Italy (Raymarine subsidiary) | <ul style="list-style-type: none">• E-Mail: support.it@raymarine.com• Tel: +39 02 9945 1001 |
| Spain (Authorized Raymarine distributor) | <ul style="list-style-type: none">• E-Mail: sat@azimut.es• Tel: +34 96 2965 102 |
| Netherlands (Raymarine subsidiary) | <ul style="list-style-type: none">• E-Mail: support.nl@raymarine.com• Tel: +31 (0)26 3614 905 |

| Region | Contact |
|----------------------------------------------|------------------------------------------------------------------------------------------------------------------------------------------------------------------------|
| Sweden (Raymarine subsidiary) | <ul style="list-style-type: none"> • E-Mail: support.se@raymarine.com • Tel: +46 (0)317 633 670 |
| Finland (Raymarine subsidiary) | <ul style="list-style-type: none"> • E-Mail: support.fi@raymarine.com • Tel: +358 (0)207 619 937 |
| Norway (Raymarine subsidiary) | <ul style="list-style-type: none"> • E-Mail: support.no@raymarine.com • Tel: +47 692 64 600 |
| Denmark (Raymarine subsidiary) | <ul style="list-style-type: none"> • E-Mail: support.dk@raymarine.com • Tel: +45 437 164 64 |
| Russia (Authorized Raymarine distributor) | <ul style="list-style-type: none"> • E-Mail: info@mikstmarine.ru • Tel: +7 495 788 0508 |

12.2 Viewing product information

Product information can be found on the Startup screen.

1. Power up the radio.



The startup screen is displayed which shows the model and software version of the product.

Alternatively product information can also be displayed by selecting **About this unit** from the **Maintenance** menu: **Menu > Set-up > Maintenance**.

12.3 Learning resources

Raymarine has produced a range of learning resources to help you get the most out of your products.

Video tutorials

| | |
|--------------------------------------------------------------------------------------------------|---------------------------------------------------------------------------------------------------------------------------------------------------------------------------------------------------------------------------------------------------------------------------------------------------------------------------------------------------------------------------------------------------------------------------------------------------|
|  YouTube | Raymarine official channel on YouTube: <ul style="list-style-type: none">• http://www.youtube.com/user/RaymarineInc LightHouse™ 3 tips and tricks: <ul style="list-style-type: none">• http://www.raymarine.com/multifunction-displays/light-house3/tips-and-tricks |
|  | Video Gallery: <ul style="list-style-type: none">• http://www.raymarine.co.uk/view/?id=2679 |

Note:

- Viewing the videos requires a device with an Internet connection.
- Some videos are only available in English.

Training courses

Raymarine regularly runs a range of in-depth training courses to help you make the most of your products. Visit the Training section of the Raymarine website for more information:

- <http://www.raymarine.co.uk/view/?id=2372>

FAQs and Knowledge Base

Raymarine has produced an extensive set of FAQs and a Knowledge Base to help you find more information and troubleshoot any issues.

- <http://www.raymarine.co.uk/knowledgebase/>

Technical support forum

You can use the Technical support forum to ask a technical question about a Raymarine product or to find out how other customers are using their Raymarine equipment. The resource is regularly updated with contributions from Raymarine customers and staff:

- <http://forum.raymarine.com>

Chapter 13: Technical specification

Chapter contents

- 13.1 Technical specification — Ray53 on page 178
- 13.2 Technical specification — Ray63 on page 180
- 13.3 Technical specification — Ray73 on page 182
- 13.4 Technical specification — Wired handset (Raymic) on page 184
- 13.5 Technical specification - Wired (Passive) speaker on page 185
- 13.6 Technical specification - Wireless hub on page 186
- 13.7 Technical specification - Wireless handset on page 187
- 13.8 Technical specification - Wireless handset charging holster on page 188
- 13.9 Technical specification - Wireless (Active) speaker on page 189

13.1 Technical specification – Ray53

Environmental specification

| | |
|-----------------------|----------------------------------------------------------------------------------------------------------------------------------------------------------------------------|
| Operating temperature | -20°C (-4°F) to +60°C (140°F) |
| Storage temperature | -25°C (-13°F) to +70°C (158°F) |
| Relative humidity | 95% |
| Water proofing | IPx6 & IPx7 |
| Connections | <ul style="list-style-type: none"> • 1 x NMEA 0183 • 1 x SeaTalkng® / NMEA 2000 • 1 x Audio (RCA) • 1 x GNSS (GPS) antenna (TNC) |

Power specification

| | |
|-------------------------|---------------------------------------------------------------------------------------------------------------------------------------------|
| Nominal supply voltage | 12 V dc (Reverse polarity and over voltage protection) |
| Operating voltage range | 9 V dc to 16 V dc |
| Current consumption | <ul style="list-style-type: none"> • Less than 6 A at high power (13.6 V) • Standby: 600 mA • Receive: 2 A |

Transmitter

| | |
|---------------------|------------------------------------------------------------------------------------------------------------------|
| Channels | All available US, International and Canadian VHF marine bands |
| Frequency Range | 156.000 MHz to 157.425 MHz / 155.500 MHz to 161.425 MHz (Private channels) |
| Frequency stability | +/- 1.5 ppm |
| Channel Spacing | 12.5 kHz |
| Power Output | <ul style="list-style-type: none"> • Low power setting – 1 W • High power setting – 25 W |
| Spurious emissions | Better than –36 dBm at 25 W (Less than 0.25 µW) |
| Maximum deviation | +/- 5 kHz |
| Antenna impedance | 50 Ohms (typical) |

Receiver

| | |
|------------------------------|----------------------------------------------------------------------------------------------------------------------------------------------------------------|
| Receiver type | Double conversion super heterodyne |
| Channels | All available US, International and Canadian VHF marine bands |
| Frequency range | 156.050 MHz to 163.275 MHz / 155.500 MHz to 161.425 MHz (Private channels) |
| Sensitivity | Better than 1 microvolt EMF @ 20dB SINAD |
| Squelch sensitivity | Less than –2 dBµ EMF |
| Hum and noise | Better than –40 dB |
| Audio distortion | Less than 10% |
| Receiver sensitivity | <ul style="list-style-type: none"> • Distance – 119dBm (0.25uV) @ 12dB SINAD (typical) • Local – 110dBm (0.7uV) @ 12dB SINAD (typical) |
| Adjacent channel selectivity | More than 70 dB |
| Spurious response rejection | More than 70 dB |
| Inter modulation rejection | More than 68 dB |

Speakers

| | |
|-----------------------------------|---------------------|
| Base station speaker power output | 2.5 W (8 Ω) |
| Fistmic speaker power | 1 W (16 Ω) |
| External speaker power | 5 W (8 Ω) |

GNSS (GPS)

| | |
|--------------------------------|----------------------------------------------------------------------------------------------------------------------------------------------------------------------|
| Channels | 72 |
| Cold start | < 2 minutes |
| Receiver IC Sensitivity | -167 dBm (Tracking) / -148 dBm (Acquisition) |
| GNSS compatibility | <ul style="list-style-type: none">• GPS• GLONASS• * Beidou |
| SBAS compatibility | <ul style="list-style-type: none">• WAAS• EGNOS• MSAS |
| Special features | Active Jamming and Interference Reduction |
| Operating frequency | <ul style="list-style-type: none">• GPS L1 C/A• GLONASS L10F• Beidou B1 |
| Signal Acquisition | Automatic |
| Almanac Update | Automatic |
| Geodetic Datum | WGS-84 (alternatives available through Raymarine MFD) |
| Refresh Rate | 10 Hz (10 times per second Concurrent GNSS) |
| Antenna | <ul style="list-style-type: none">• Internal — Ceramic chip mounted near top of unit• External — Passive antenna connection via TNC connector |
| Position Accuracy | <ul style="list-style-type: none">• Without SBAS: <= 15 metres 95% of the time• With SBAS: <= 5 metres 95% of the time |

13.2 Technical specification – Ray63

Environmental specification

| | |
|-----------------------|------------------------------------------------------------------------------------------------------------------------------------------------------------------------------------------------------------------------------------------------------------------------------|
| Operating temperature | -20°C (-4°F) to +60°C (140°F) |
| Storage temperature | -25°C (-13°F) to +70°C (158°F) |
| Relative humidity | 95% |
| Water proofing | IPx6 & IPx7 |
| Connections | <ul style="list-style-type: none"> • 1 x NMEA 0183 • 1 x SeaTalkng® / NMEA 2000 • 1 x Front Fistmic connection • 1 x Rear connection for 2nd station • 1 x Audio (RCA) • 1 x GNSS (GPS) antenna (TNC) |

Power specification

| | |
|-------------------------|---------------------------------------------------------------------------------------------------------------------------------------------|
| Nominal supply voltage | 12 V dc (Reverse polarity and over voltage protection) |
| Operating voltage range | 9 V dc to 16 V dc |
| Current consumption | <ul style="list-style-type: none"> • Less than 6 A at high power (13.6 V) • Standby: 600 mA • Receive: 2 A |

Transmitter

| | |
|---------------------|------------------------------------------------------------------------------------------------------------------|
| Channels | All available US, International and Canadian VHF marine bands |
| Frequency Range | 156.000 MHz to 157.425 MHz / 155.500 MHz to 161.425 MHz (Private channels) |
| Frequency stability | +/- 1.5 ppm |
| Channel Spacing | 12.5 kHz |
| Power Output | <ul style="list-style-type: none"> • Low power setting — 1 W • High power setting — 25 W |
| Spurious emissions | Better than -36 dBm at 25 W (Less than 0.25 µW) |
| Maximum deviation | +/- 5 kHz |
| Antenna impedance | 50 Ohms (typical) |

Receiver

| | |
|------------------------------|----------------------------------------------------------------------------------------------------------------------------------------------------------------|
| Receiver type | Double conversion super heterodyne |
| Channels | All available US, International and Canadian VHF marine bands |
| Frequency range | 156.050 MHz to 163.275 MHz / 155.500 MHz to 161.425 MHz (Private channels) |
| Sensitivity | Better than 1 microvolt EMF @ 20dB SINAD |
| Squelch sensitivity | Less than -2 dBµ EMF |
| Hum and noise | Better than -40 dB |
| Audio distortion | Less than 10% |
| Receiver sensitivity | <ul style="list-style-type: none"> • Distance — 119dBm (0.25uV) @ 12dB SINAD (typical) • Local — 110dBm (0.7uV) @ 12dB SINAD (typical) |
| Adjacent channel selectivity | More than 70 dB |

| | |
|-----------------------------|-----------------|
| Spurious response rejection | More than 70 dB |
| Inter modulation rejection | More than 68 dB |

Speakers

| | |
|-----------------------------------|-------------|
| Base station speaker power output | 2.5 W (8 Ω) |
| Fistmic speaker power output | 1 W (16 Ω) |
| External speaker power output | 5 W (8 Ω) |
| Handset speaker power output | 1 W (16 Ω) |

GNSS (GPS)

| | |
|--------------------------------|-------------------------------------------------------------------------------------------------------------------------------------------------------------------------|
| Channels | 72 |
| Cold start | < 2 minutes |
| Receiver IC Sensitivity | -167 dBm (Tracking) / -148 dBm (Acquisition) |
| GNSS compatibility | <ul style="list-style-type: none"> • GPS • GLONASS • * Beidou |
| SBAS compatibility | <ul style="list-style-type: none"> • WAAS • EGNOS • MSAS |
| Special features | Active Jamming and Interference Reduction |
| Operating frequency | <ul style="list-style-type: none"> • GPS L1 C/A • GLONASS L10F • Beidou B1 |
| Signal Acquisition | Automatic |
| Almanac Update | Automatic |
| Geodetic Datum | WGS-84 (alternatives available through Raymarine MFD) |
| Refresh Rate | 10 Hz (10 times per second Concurrent GNSS) |
| Antenna | <ul style="list-style-type: none"> • Internal — Ceramic chip mounted near top of unit • External — Passive antenna connection via TNC connector |
| Position Accuracy | <ul style="list-style-type: none"> • Without SBAS: <= 15 metres 95% of the time • With SBAS: <= 5 metres 95% of the time |

13.3 Technical specification – Ray73

Environmental specification

| | |
|-----------------------|--------------------------------------------------------------------------------------------------------------------------------------------------------------------------------------------------------------------------------------------------------------------------------------------------------------------------|
| Operating temperature | -20°C (-4°F) to +60°C (140°F) |
| Storage temperature | -25°C (-13°F) to +70°C (158°F) |
| Relative humidity | 95% |
| Water proofing | IPx6 & IPx7 |
| Connections | <ul style="list-style-type: none"> • 1 x NMEA 0183 • 1 x SeaTalkng® / NMEA 2000 • 1 x Front Fistmic connection • 1 x Rear connection for 2nd station • 1 x Audio (RCA) • 1 x Loud Hailer connection wires • 1 x GNSS (GPS) antenna (TNC) |

Power specification

| | |
|-------------------------|-------------------------------------------------------------------------------------------------------------------------------------------------------------------------------------------|
| Nominal supply voltage | 12 V dc (Reverse polarity and over voltage protection) |
| Operating voltage range | 9 V dc to 16 V dc |
| Current consumption | <ul style="list-style-type: none"> • Less than 6 A at high power (13.6 V) • Standby: 600 mA • Receive: 2 A • Loud hailer: 3 A (8 Ω) / 6 A (4 Ω) |

Transmitter

| | |
|---------------------|------------------------------------------------------------------------------------------------------------------|
| Channels | All available US, International and Canadian VHF marine bands |
| Frequency Range | 156.000 MHz to 157.425 MHz / 155.500 MHz to 161.425 MHz (Private channels) |
| Frequency stability | +/- 1.5 ppm |
| Channel Spacing | 12.5 kHz |
| Power Output | <ul style="list-style-type: none"> • Low power setting – 1 W • High power setting – 25 W |
| Spurious emissions | Better than –36 dBm at 25 W (Less than 0.25 μW) |
| Maximum deviation | +/- 5 kHz |
| Antenna impedance | 50 Ohms (typical) |

Receiver

| | |
|---------------------|----------------------------------------------------------------------------|
| Receiver type | Double conversion super heterodyne |
| Channels | All available US, International and Canadian VHF marine bands |
| Frequency range | 156.050 MHz to 163.275 MHz / 155.500 MHz to 161.425 MHz (Private channels) |
| Sensitivity | Better than 1 microvolt EMF @ 20dB SINAD |
| Squelch sensitivity | Less than –2 dBμ EMF |
| Hum and noise | Better than –40 dB |
| Audio distortion | Less than 10% |

| | |
|------------------------------|------------------------------------------------------------------------------------------------------------------------------------------------------------|
| Receiver sensitivity | <ul style="list-style-type: none"> Distance — 119dBm (0.25uV) @ 12dB SINAD (typical) Local — 110dBm (0.7uV) @ 12dB SINAD (typical) |
| Adjacent channel selectivity | More than 70 dB |
| Spurious response rejection | More than 70 dB |
| Inter modulation rejection | More than 68 dB |

Speakers

| | |
|-----------------------------------|-------------------------|
| Base station speaker power output | 2.5 W (8 Ω) |
| Fistmic speaker power output | 1 W (16 Ω) |
| External speaker power output | 5 W (8 Ω) |
| Handset speaker power output | 1 W (16 Ω) |
| Hailer speaker power output | 25 W (4 Ω) / 12 W (8 Ω) |

AIS

| | |
|------------|-------------------|
| Class type | AIS receiver only |
|------------|-------------------|

GPS

| | |
|--------------------------------|-------------------------------------------------------------------------------------------------------------------------------------------------------------------------|
| Channels | 72 |
| Cold start | < 2 minutes |
| Receiver IC Sensitivity | -167 dBm (Tracking) / -148 dBm (Acquisition) |
| GNSS compatibility | <ul style="list-style-type: none"> • GPS • GLONASS • * Beidou |
| SBAS compatibility | <ul style="list-style-type: none"> • WAAS • EGNOS • MSAS |
| Special features | Active Jamming and Interference Reduction |
| Operating frequency | <ul style="list-style-type: none"> • GPS L1 C/A • GLONASS L10F • Beidou B1 |
| Signal Acquisition | Automatic |
| Almanac Update | Automatic |
| Geodetic Datum | WGS-84 (alternatives available through Raymarine MFD) |
| Refresh Rate | 10 Hz (10 times per second Concurrent GNSS) |
| Antenna | <ul style="list-style-type: none"> • Internal — Ceramic chip mounted near top of unit • External — Passive antenna connection via TNC connector |
| Position Accuracy | <ul style="list-style-type: none"> • Without SBAS: <= 15 metres 95% of the time • With SBAS: <= 5 metres 95% of the time |

13.4 Technical specification — Wired handset (Raymic)

The following technical specifications apply to the Wired handset.

| | |
|--------------------------|-----------------------------------------------------------------------------------------------------------------|
| Operating temperature | -25°C (-13°F) to +55°C (131°F) |
| Storage temperature | -25°C (-13°F) to +70°C (158°F) |
| Relative humidity | 95% |
| Water proofing | IPx6 & IPx7 |
| Max speaker power output | 1 W (16 Ω) |
| VHF radio compatibility | <ul style="list-style-type: none">• Ray90 / Ray91• Ray63 / Ray73• Ray60 / Ray70 |

13.5 Technical specification - Wired (Passive) speaker

| | |
|--------------------------|-----------------------------------------------------------------------------------------------------------------------------------------|
| Operating temperature | -25°C (-13°F) to +55°C (131°F) |
| Storage temperature | -25°C (-13°F) to +70°C (158°F) |
| Relative humidity | 95% |
| Water proofing | IPx6 & IPx7 |
| Max speaker power output | 5 W (8 Ω) |
| Connection | RCA female connector, connects to Wired handset via adaptor cable (A80297) |
| VHF radio compatibility | <ul style="list-style-type: none">• Ray90 / Ray91• Ray53 / Ray63 / Ray73• Ray50 / Ray52 / Ray60 / Ray70 |

13.6 Technical specification - Wireless hub

The following technical specification applies to the Wireless hub accessory.

| | |
|-------------------------|-----------------------------------------------------------------------------------------------------------------------------------------------------------------------|
| Operating temperature | -25°C (-13°F) to +55°C (131°F) |
| Storage temperature | -25°C (-13°F) to +70°C (158°F) |
| Relative humidity | 95% |
| Water proofing | IPx6 & IPx7 |
| Wireless frequency | 2.4 GHz |
| Connections | <ul style="list-style-type: none">• Connects to Base station via 12 pin connector.• Connects wireless handsets via 2.4GHz wireless connection. |
| VHF radio compatibility | <ul style="list-style-type: none">• Ray90 / Ray91• Ray63• Ray73 |

13.7 Technical specification - Wireless handset

Wireless handset

| | |
|--------------------------|-------------------------------------------------------------------------------------------------------------------------------------------------------------------------------------|
| Operating temperature | -25°C (-13°F) to +55°C (131°F) |
| Storage temperature | -25°C (-13°F) to +70°C (158°F) |
| Relative humidity | 95% |
| Water proofing | IPx6 & IPx7 |
| Max speaker power output | 1 W (16 Ω) |
| Wireless frequency | 2.4 GHz |
| Connections | <ul style="list-style-type: none">• x 1 Wireless hub connection via 2.4GHz wireless connection• x 1 Wireless (Active) speaker via 2.4GHz wireless connection |
| VHF radio compatibility | <ul style="list-style-type: none">• Ray90 / Ray91• Ray63 / Ray73 |

Battery

| | |
|--------------|--------------------------|
| Battery type | Rechargeable Lithium ion |
| Replaceable | No |
| Capacity | 2000 mAh |
| Talk time | 8 hours |
| Standby | 100 hours |
| Charge time | 5 hours |

13.8 Technical specification - Wireless handset charging holster

Power specification

| | |
|-------------------------|-----------------------------------------------------------------------------------------------------|
| Nominal supply voltage | 12 V dc (with over voltage protection) |
| Operating voltage range | 10.2 V dc to 16 V dc |
| Fuse requirements | <ul style="list-style-type: none">• Inline fuse = 2 A• Thermal breaker = 2 A |
| Current consumption | 1 A nominal |
| Charge type | Wireless inductive charging |
| Power output | 1 A |

Environmental specification

| | |
|-----------------------|--------------------------------|
| Operating temperature | -25°C (-13°F) to +55°C (131°F) |
| Storage temperature | -25°C (-13°F) to +70°C (158°F) |
| Relative humidity | 95% |
| Water proofing | IPx6 & IPx7 |

13.9 Technical specification - Wireless (Active) speaker

Power specification

| | |
|--------------------------|-----------------------------------------------------------------------------------------------------|
| Nominal supply voltage | 12 V dc (with over voltage protection) |
| Operating voltage range | 10.2 V dc to 16 V dc |
| Fuse requirements | <ul style="list-style-type: none">• Inline fuse = 2 A• Thermal breaker = 2 A |
| Current consumption | 1 A nominal |
| Max speaker power output | 5 W (8 Ω) |

Environmental specification

| | |
|-----------------------|--------------------------------|
| Operating temperature | -25°C (-13°F) to +55°C (131°F) |
| Storage temperature | -25°C (-13°F) to +70°C (158°F) |
| Relative humidity | 95% |
| Water proofing | IPx6 & IPx7 |

Connections

| | |
|--------------------------------------------|-----------------------------------------------------------------------------------------|
| Connection | x 1 Wireless handset connection via 2.4GHz Wireless connection |
| VHF radio compatibility (via wireless hub) | <ul style="list-style-type: none">• Ray90 / Ray91• Ray63 / Ray73 |

Chapter 14: Spares and accessories

Chapter contents

- [14.1 Accessories on page 192](#)
- [14.2 Ray53 / Ray63 / Ray73 spares on page 193](#)
- [14.3 SeaTalkng[®] cables and accessories on page 194](#)

14.1 Accessories

The following accessories are available;

Base station accessories

| Part number | Description |
|-------------|----------------------------|
| A80288 | Passive GNSS (GPS) antenna |
| M95435 | Loud hailer / Fog horn |

Wired handset station accessories

| Part number | Description |
|-------------|-----------------------------------------------------------------|
| A80542 | Wired passive speaker |
| A80289 | Wired handset including mounting holster |
| A80291 | Wired handset extension cable 5 m (16.4 ft) |
| A80292 | Wired handset extension cable 10 m (32.8 ft) |
| A80290 | Wired handset extension cable 15 m (49.2 ft) |
| A80297 | Wired handset adaptor cable with male RCA audio (400 mm 1.3 ft) |

Wireless handset station accessories

| Part number | Description |
|-------------|---------------------------------------------|
| A80540 | Wireless hub |
| A80541 | Wireless hub antenna extension 5m (16.4 ft) |
| A80543 | Wireless active speaker |
| A80544 | Wireless handset including charging holster |
| R70739 | Wireless hub adaptor for Ray63/Ray73 |

14.2 Ray53 / Ray63 / Ray73 spares

The following spares are available:

| | |
|--------|--------------------------------------------------|
| R70616 | Wireless handset |
| R70617 | Wireless handset charging holster |
| R70618 | Volume knob for the wireless active speaker |
| R70619 | Bezel for passive and active speaker |
| R70492 | Wired handset holster |
| R70438 | Panel mount fixing kit |
| R70484 | Handset hook plate (mounting clip) |
| R70432 | Volume/Squelch control knob and OK knob (Chrome) |
| R70737 | Volume/Squelch control knob and OK knob (Black) |
| R70620 | Black bezel (Ray63 / Ray73) |
| A80620 | Suncover (Ray63 / Ray73) |
| R70689 | Wireless hub antenna |

14.3 SeaTalkng[®] cables and accessories

SeaTalkng[®] cables and accessories for use with compatible products.

| Part No | Description | Notes |
|---------|------------------------------------------------------------------------|-------------------------------------------------------------------------------------------------------------------------------------------------------------------------------------------------------------------------------------------------------------------------------|
| T70134 | Starter kit | Includes: <ul style="list-style-type: none"> • 1 x 5 Way connector (A06064) • 2 x Backbone terminator (A06031) • 1 x 3 m (9.8 ft) spur cable (A06040) • 1 x Power cable (A06049) |
| A25062 | Backbone Kit | Includes: <ul style="list-style-type: none"> • 2 x 5 m (16.4 ft) Backbone cable (A06036) • 1 x 20 m (65.6 ft) Backbone cable (A06037) • 4 x T-piece (A06028) • 2 x Backbone terminator (A06031) • 1 x Power cable (A06049) |
| A06038 | Spur cable 0.4 m (1.3 ft) | |
| A06039 | Spur cable 1 m (3.3 ft) | |
| A06040 | Spur cable 3 m (9.8 ft) | |
| A06041 | Spur cable 5 m (16.4 ft) | |
| A06042 | Elbow spur cable 0.4 m (1.3 ft) | |
| A06033 | Backbone cable 0.4 m (1.3 ft) | |
| A06034 | Backbone cable 1 m (3.3 ft) | |
| A06035 | Backbone cable 3 m (9.8 ft) | |
| A06036 | Backbone cable 5 m (16.4 ft) | |
| A06068 | Backbone cable 9 m (29.5 ft) | |
| A06037 | Backbone cable 20 m (65.6 ft) | |
| A06043 | SeaTalkng [®] to bare wire spur cable 1 m (3.3 ft) | |
| A06044 | SeaTalkng [®] to bare wire spur cable 3 m (9.8 ft) | |
| A06049 | Power cable 1 m (3.3 ft) | |
| A06077 | Right angled connector | 90° right angle spur connector. |
| A06031 | Terminator | |
| A06028 | T-piece | Provides 1 x spur connection |
| A06064 | 5-way connector block | Provides 3 x spur connections |
| A06030 | Backbone extender | |
| E22158 | SeaTalk to SeaTalkng [®] converter kit | Allows the connection of SeaTalk devices to a SeaTalkng [®] system. |
| A80001 | Inline terminator | Provides direct connection of a spur cable to the end of a backbone cable. No T-piece required. |
| A06032 | Spur blanking plug | |
| R12112 | ACU / SPX SeaTalkng [®] spur cable 0.3 m (1.0 ft) | Connects an SPX course computer or an ACU to a SeaTalkng [®] backbone. |
| A06047 | SeaTalk (3 pin) to SeaTalkng [®] adaptor cable 0.4 m (1.3 ft) | |

| Part No | Description | Notes |
|----------------|---------------------------------------------------------------------------|--------------------------------------------------------------------------------|
| A22164 | SeaTalk to SeaTalkng [®] spur cable 1 m (3.3 ft) | |
| A06048 | SeaTalk2 (5 pin) to SeaTalkng [®] adaptor cable 0.4 m (1.3 ft) | |
| A06045 | SeaTalkng [®] to DeviceNet (Female) adaptor cable 0.4 m (1.3 ft) | Allows the connection of NMEA 2000 devices to a SeaTalkng [®] system. |
| A06075 | SeaTalkng [®] to DeviceNet (Female) adaptor cable 1 m (3.3 ft) | Allows the connection of NMEA 2000 devices to a SeaTalkng [®] system. |
| A06046 | SeaTalkng [®] to DeviceNet (Male) adaptor cable 1.5 m (4.92 ft) | Allows the connection of NMEA 2000 devices to a SeaTalkng [®] system. |
| A06076 | SeaTalkng [®] to DeviceNet (Male) adaptor cable 1 m (3.3 ft) | Allows the connection of NMEA 2000 devices to a SeaTalkng [®] system. |
| A06078 | SeaTalkng [®] to DeviceNet (Male) adaptor cable 0.1 m (0.33 ft) | Allows the connection of NMEA 2000 devices to a SeaTalkng [®] system. |
| E05026 | DeviceNet (Female) to bare wires adaptor cable (0.4 m (1.3 ft) | Allows the connection of NMEA 2000 devices to a SeaTalkng [®] system. |
| E05027 | DeviceNet (Male) to bare wires adaptor cable (0.4 m (1.3 ft) | Allows the connection of NMEA 2000 devices to a SeaTalkng [®] system. |

Appendix A NMEA 0183 sentences

The radio supports the following **NMEA 0183** sentences.

| Sentence | Description | Ray50 / Ray52 / Ray60 | | Ray70 | |
|----------|-------------------------------------------|-----------------------|----------|---------|----------|
| | | Receive | Transmit | Receive | Transmit |
| DSC | Digital Selective Calling | | ● | | ● |
| DSE | Expanded Digital Selective Calling | | ● | | ● |
| VDM | AIS VHF Data Link Message | | | | ● |
| GGA | Global Positioning System Fix Data | ● | | ● | |
| GLL | Geographic Position — Lat/Long | ● | | ● | |
| GNS | GNSS Fix Data | ● | | ● | |
| RMA | Recommended Minimum Specific Loran-C Data | ● | | ● | |
| RMC | Recommended Minimum Specific GNSS Data | ● | | ● | |
| DTM | Datum | ● | | ● | |

Appendix B NMEA 2000 PGN list

The radio supports the following **NMEA 2000** PGNs. These are applicable to **NMEA 2000** and **SeaTalkng®** protocols.

| PGN | Description | Ray53 / Ray63 | | Ray73 | |
|--------|--------------------------------------------|---------------|----------|---------|----------|
| | | Receive | Transmit | Receive | Transmit |
| 59392 | ISO Request | ● | ● | ● | ● |
| 59904 | ISO Acknowledgement | ● | ● | ● | ● |
| 60416 | Transport Protocol (group function BMA) | ● | | ● | |
| 60928 | ISO Address Claim | ● | ● | ● | ● |
| 65240 | ISO Commanded Address | | ● | | ● |
| 65396 | AIS Transmitter Status | | | | ● |
| 126208 | NMEA — Request Group Function | ● | | ● | |
| 126208 | NMEA — Command Group Function | ● | | ● | |
| 126208 | NMEA — Acknowledge Group Function | | ● | | ● |
| 126464 | PGN List | | ● | | ● |
| 126992 | System Time | ● | ● | ● | ● |
| 126993 | Heartbeat | | ● | | ● |
| 126996 | Product Information | | ● | | ● |
| 127258 | Magnetic variation | ● | | ● | |
| 129025 | Position Rapid Update | ● | ● | ● | ● |
| 129026 | COG / SOG Rapid Update | ● | ● | ● | ● |
| 129029 | GNSS Position Data | ● | ● | ● | ● |
| 129033 | Local Time Offset | ● | ● | ● | ● |
| 129038 | AIS Class A Position Report | | | | ● |
| 129039 | AIS Class B Position Report | | | | ● |
| 129040 | AIS Class B Extended Position Report | | | | ● |
| 129041 | AIS Aids to Navigation (AtONs) | | | | ● |
| 129044 | Datum | ● | ● | ● | ● |
| 129540 | GNSS Satellites in View | ● | ● | ● | ● |
| 129542 | GNSS Pseudo Range Noise Statistics | ● | ● | ● | ● |
| 129547 | GNSS Pseudo Range Error Statistics | ● | ● | ● | ● |
| 129793 | AIS UTC and Date Report | | | | ● |
| 129794 | AIS Class A Static and Voyage Related data | | | | ● |
| 129797 | AIS Binary Broadcast | | ● | | ● |
| 129798 | AIS SAR Aircraft Position Report | | | | ● |
| 129801 | AIS Addressed Safety Related Message | | | | ● |
| 129802 | AIS Safety Related Broadcast Message | | | | ● |
| 129808 | DSC Call Information | | ● | | ● |

| PGN | Description | Ray53 / Ray63 | | Ray73 | |
|--------|---------------------------------------------|---------------|----------|---------|----------|
| | | Receive | Transmit | Receive | Transmit |
| 129809 | AIS Class B "CS" Static Data Report, Part A | | | | ● |
| 129810 | AIS Class B "CS" Static Data Report, Part B | | | | ● |

Appendix C MMSI Regulatory bodies and application submissions

| Country | Regulatory Body | Website links |
|-------------|--------------------------------------------------------------------------------------|---------------------------------------------------------------------------------------------------------------------------------------------------------------------------------------------------------------------------------------------------------------------------------------------------------------------------|
| UK | Ofcom | http://www.ofcom.org.uk |
| USA | FCC (www.fcc.gov) | <ul style="list-style-type: none"> • www.boatus.com • www.seatow.com • www.usps4mmsi.com |
| Canada | Industry Canada | www.ic.gc.ca |
| Australia | Australian Maritime Safety Authority (AMSA) | http://www.amsa.gov.au/mmsi/ |
| Holland | Agentschap Telecom | www.agentschaptelecom.nl |
| Belgium | Belgisch Instituut voor Postdiensten en Telecommunicatie | www.bipt.be |
| Germany | Bundesnetzagentur | https://www.bundesnetzagentur.de/DE/Sachgebiete/Telekommunikation/Unternehmen_Institutionen/Frequenzen/SpezielleAnwendungen/Seefunk/Seefunk-node.html |
| Denmark | søfartsstyrelsen | www.sofartsstyrelsen.dk |
| France | Agence Nationale Des Fréquences | https://www.anfr.fr/licences-et-autorisations/radiomaritime/ |
| Italy | Ministero dello sviluppo economico - Direzione generale per le attività territoriali | http://www.sviluppoeconomico.gov.it/images/stories/documenti/mmsinew.pdf |
| Spain | Ministero De Fomento | https://www.fomento.gob.es/MFOM/LANG_CASTELLANO/DIRECCIONES_GENERALES/MARINA_MERCANTE/RADIOCOMUNICACIONES/MMSI/ |
| Sweden | PTS | www.pts.se |
| Finland | Viestintävirasto | https://www.viestintavirasto.fi/en/spectrum/radiolicensences/Boatingandnavigation.html |
| Iceland | Post and telecom administration in Iceland | www.pfs.is |
| New Zealand | Radio Spectrum Management | https://www.rsm.govt.nz/licensing/radio-operator-certificates-and-callsigns?searchterm=MMSI |
| Chile | Directemar | www.nauticentro.cl |
| Panama | Autoridad Maritima de Panama | www.amp.gob.pa/newside/spanish/puertos2/de-pima/ima.html |

Appendix D VHF Channels

International Marine VHF Channels and Frequencies

| CH No. | TX Freq | RX Freq (MHz) | Single Freq (MHz) | Use |
|--------|---------|---------------|-------------------|-----------------------------------------------------------------------------------------------------------------------------------------------------------------------------|
| 01 | 156.050 | 160.650 | | Public correspondence, Port operations and Ship movement. |
| 02 | 156.100 | 160.700 | | Public correspondence, Port operations and Ship movement. |
| 03 | 156.150 | 160.750 | | Public correspondence, Port operations and Ship movement. |
| 04 | 156.200 | 156.800 | | Public correspondence, Port operations and Ship movement. |
| 05 | 156.250 | 156.850 | | Public correspondence, Port operations and Ship movement. |
| 06 | 156.300 | 156.300 | x | Intership. Coordinated search and rescue and ship stations working frequency |
| 07 | 156.350 | 160.950 | | Public correspondence, Port operations and Ship movement. |
| 08 | 156.400 | 156.400 | x | Intership. Preferred intership channel |
| 09 | 156.450 | 156.450 | x | Intership, Port operations and Ship movement. |
| 10 | 156.500 | 156.500 | x | Intership, Port operations and Ship movement. SAR, Pollution incidents, MSI broadcasts coordinated with HMCG. |
| 11 | 156.550 | 156.550 | x | Port operations and Ship movement. |
| 12 | 156.600 | 156.600 | x | Port operations and Ship movement. |
| 13 | 156.650 | 156.650 | x | Intership navigation safety (Bridge-to-bridge). International navigation safety channel. May also be used for ship movement, port operations and limited coast stations. |
| 14 | 156.700 | 156.700 | x | Port operations and Ship movement. |
| 15 | 156.750 | 156.750 | x | On-board communications. 1 watt maximum power. |
| 16 | 156.800 | 156.800 | x | International Distress, Safety and Calling. |
| 17 | 156.850 | 156.850 | x | On-board communications. 1 watt maximum power. |
| 18 | 156.900 | 161.500 | | Public correspondence, Port operations and Ship movement. |
| 19 | 156.950 | 161.550 | | Public correspondence, Port operations and Ship movement. |
| 1019 | 156.950 | 156.950 | x | Port operations and Ship movement. |
| 2019 | 161.550 | 161.550 | x | Port operations and Ship movement. Channel is limited to coast stations only unless otherwise permitted by UK regulation. |
| 20 | 157.000 | 161.600 | | Public correspondence, Port operations and Ship movement. |
| 1020 | 157.000 | 157.000 | x | Public correspondence, Port operations and Ship movement. |
| 2020 | 161.600 | 161.600 | x | Public correspondence, Port operations and Ship movement. Channel is limited to coast stations only unless otherwise permitted by UK regulation. |
| 21 | 157.050 | 161.650 | | Public correspondence, Port operations and Ship movement. Available for VDSMS |
| 22 | 157.100 | 161.700 | | Public correspondence, Port operations and Ship movement. Available for VDSMS |
| 23 | 157.150 | 161.750 | | Safety. HNCG — SAR and MSI broadcasts. |
| 24 | 157.200 | 161.800 | | Public correspondence, Port operations and Ship movement. Available for VDSMS |

| CH No. | TX Freq | RX Freq (MHz) | Single Freq (MHz) | Use |
|--------|---------|---------------|-------------------|----------------------------------------------------------------------------------------------------------|
| 1024 | 157.200 | 157.200 | x | For future use |
| 2024 | 161.800 | 161.800 | x | For future use |
| 25 | 157.250 | 161.850 | | Public correspondence, Port operations and Ship movement. Available for VDSMS |
| 1025 | 157.250 | 157.250 | x | For future use |
| 2025 | 161.850 | 161.850 | x | For future use |
| 26 | 157.300 | 161.900 | | Public correspondence, Port operations and Ship movement. Available for VDSMS |
| 1026 | 157.300 | 157.300 | x | For future use |
| 2026 | 161.900 | 161.900 | x | For future use |
| 27 | 157.350 | 161.950 | | Public correspondence, Port operations and Ship movement. Available for testing of new AIS applications. |
| 1027 | 157.350 | 157.350 | x | Port operations and Ship movement. |
| 2027 | 161.950 | 161.950 | x | Application specific message (ASM1) |
| 28 | 157.400 | 162.000 | | Public correspondence, Port operations and Ship movement. Available for testing of new AIS applications. |
| 1028 | 157.400 | 157.400 | x | Port operations and Ship movement. |
| 2028 | 162.00 | 162.00 | x | Application specific message (ASM2) |
| 60 | 156.025 | 160.625 | | Public correspondence, Port operations and Ship movement. |
| 61 | 156.075 | 160.675 | | Public correspondence, Port operations and Ship movement. |
| 62 | 156.125 | 160.725 | | Public correspondence, Port operations and Ship movement. |
| 63 | 156.175 | 160.775 | | Public correspondence, Port operations and Ship movement. |
| 64 | 156.225 | 160.825 | | Public correspondence, Port operations and Ship movement. |
| 65 | 156.275 | 160.875 | | UK National Coastwatch. |
| 66 | 156.325 | 160.925 | | Public correspondence, Port operations and Ship movement. |
| 67 | 156.375 | 156.375 | x | Intership, Port operations and Ship movement. HMCG — SAR and Safety. |
| 68 | 156.425 | 156.425 | x | Port operations and Ship movement. |
| 69 | 156.475 | 156.475 | x | Intership, Port operations and Ship movement. |
| 71 | 156.575 | 156.575 | x | Port operations and Ship movement. |
| 72 | 156.625 | 156.625 | x | Intership. Preferred intership channel. |
| 73 | 156.675 | 156.675 | x | Intership, Port operations and Ship movement. HMCG — SAR and MSI broadcasts. |
| 74 | 156.725 | 156.725 | x | Port operations and Ship movement. |
| 75 | 156.775 | 156.775 | x | Intership Navigation related communications only with 1 watt maximum power. |
| 76 | 156.825 | 156.825 | x | Intership Navigation related communications only with 1 watt maximum power. |
| 77 | 156.875 | 156.875 | x | Intership. Preferred intership channel. |
| 78 | 156.925 | 161.525 | | Public correspondence, Port operations and Ship movement. |
| 1078 | 156.925 | 156.925 | x | Port operations and Ship movement. |

| CH No. | TX Freq | RX Freq (MHz) | Single Freq (MHz) | Use |
|--------|---------|---------------|-------------------|------------------------------------------------------------------------------------------------------------------------------|
| 2078 | 161.525 | 161.525 | x | Port operations and Ship movement. Channel is limited to coast stations only unless otherwise permitted by UK regulation. |
| 79 | 156.975 | 161.575 | | Public correspondence, Port operations and Ship movement. |
| 1079 | 156.975 | 156.975 | x | Port operations and Ship movement. |
| 2079 | 161.575 | 161.575 | x | Port operations and Ship movement. Channel is limited to coast stations only unless otherwise permitted by UK regulation. |
| 80 | 157.025 | 161.625 | | Public correspondence, Port operations and Ship movement. Also marinas and yacht clubs UK only. Available for VDSMS. |
| 81 | 157.075 | 161.675 | | Public correspondence, Port operations and Ship movement. Available for VDSMS |
| 82 | 157.125 | 161.725 | | Public correspondence, Port operations and Ship movement. Available for VDSMS |
| 83 | 157.175 | 161.775 | | Public correspondence, Port operations and Ship movement. Available for VDSMS |
| 84 | 157.225 | 161.825 | | Port operations and Ship movement. HMCG — SAR and MSI broadcasts. |
| 1084 | 157.225 | 157.225 | x | For future use |
| 2084 | 161.825 | 161.825 | x | For future use |
| 85 | 157.275 | 161.875 | | Public correspondence, Port operations and Ship movement. Available for VDSMS |
| 1085 | 157.275 | 157.275 | x | For future use |
| 2085 | 161.875 | 161.875 | x | For future use |
| 86 | 157.325 | 161.925 | | Port operations and Ship movement. HMCG — SAR and MSI broadcasts. |
| 1086 | 157.325 | 157.325 | x | For future use |
| 2086 | 161.925 | 161.925 | x | For future use |
| 87 | 157.375 | 157.375 | x | Port operations and Ship movement. Available for testing of new AIS applications. |
| 88 | 157.425 | 157.425 | x | Port operations and Ship movement. Available for testing of new AIS applications. |

Please be aware that:

- Intership channels are for communications between ship stations. Intership communications should be restricted to channels 6, 8, 72 and 77. If these are not available, the other channels marked for Intership may be used.
- Channel 70 is used exclusively for Digital Selective Calling (DSC) and is not available for regular voice communications.

Note:

1. Channel 06 may also be used for communications between ship stations and aircraft engaged in coordinated search and rescue operations. Ship stations should avoid harmful interference to such communications on channel 06 as well as to communications between aircraft stations, ice breakers and assisted ships during ice seasons.
2. Within the European Maritime Area and in Canada, channels 10, 67 and 73 may also be used by the individual administrations concerned for communication between ship stations, aircraft stations and participating land stations engaged in coordinated search and rescue and anti-pollution operations in local areas. Channel 10 or 73 (depending on location) are also used for the broadcast of Marine Safety Information by the Maritime and Coast Guard Agency in the UK only.
3. Channel 13 is designated for use on a worldwide basis as a navigation safety communication channel, primarily for intership navigation safety communications.

4. Channels 15 and 17 may also be used for on-board communications provided the effective radiated power does not exceed 1 Watt.
5. The use of channels 75 and 76 should be restricted to navigation related communications only and all precautions should be taken to avoid harmful interference to channel 16. Transmit power is limited to 1 Watt.

Private Channels (Europe only)

| Country | Channel Designations | TX Freq | RX Freq | Channel Use |
|-----------------------------------|----------------------|---------|---------|-------------|
| Belgium | 96 | 162.425 | 162.425 | Marina |
| Denmark | L1 | 155.500 | 155.500 | Pleasure |
| | L2 | 155.525 | 155.525 | Pleasure |
| Finland, Norway & Sweden | L1 | 155.500 | 155.500 | Pleasure |
| | L2 | 155.525 | 155.525 | Pleasure |
| | L3 | 155.650 | 155.650 | Pleasure |
| Holland (Netherlands) | 31 | 157.550 | 162.150 | Marina |
| | 37 | 157.850 | 157.850 | Leisure |
| Denmark, Finland, Norway & Sweden | F1 | 155.625 | 155.625 | Fishing |
| | F2 | 155.775 | 155.775 | Fishing |
| | F3 | 155.825 | 155.825 | Fishing |
| United Kingdom | M1 | 157.850 | 157.850 | Marina |
| | M2 | 161.425 | 161.425 | Marina |

The national channels listed above have been allocated for the specific use within the countries listed. To use these channels you must have the appropriate license.

US Marine VHF Channels and Frequencies

Note:

Some of the channel numbers have recently changed. For completeness, both old and new numbers are shown in the table below.

| (New) CH No. | (Old) CH No. | TX Freq (MHz) | RX Freq (MHz) | Single Freq | Use |
|--------------|--------------|---------------|---------------|-------------|----------------------------------------------------------------------------------------------|
| 1001 | 01A | 156.050 | 156.050 | x | Port operations and commercial, VTS. Available only in New Orleans / Lower Mississippi area. |
| 1005 | 05A | 156.250 | 156.250 | x | Port operations or VTS in the Houston, New Orleans and Seattle areas. |
| 06 | 06 | 156.300 | 156.300 | x | Intership Safety. |
| 1007 | 07A | 156.350 | 156.350 | x | Commercial. VDSMS. |
| 08 | 08 | 156.400 | 156.400 | x | Commercial (Intership only). VDSMS. |
| 09 | 09 | 156.450 | 156.450 | x | Boater calling. Commercial and Non-commercial. VDSMS. |
| 10 | 10 | 156.500 | 156.500 | x | Commercial. VDSMS. |

| (New) CH No. | (Old) CH No. | TX Freq (MHz) | RX Freq (MHz) | Single Freq | Use |
|-----------------|-----------------|------------------|---------------------|----------------|------------------------------------------------------------------------------------------------------------------------------------------------------------|
| 11 | 11 | 156.550 | 156.55 0 | x | Commercial. VTS in selected areas. VDSMS. |
| 12 | 12 | 156.600 | 156.60 0 | x | Port operations. VTS in selected areas. |
| 13 | 13 | 156.650 | 156.65 0 | x | Intership navigation safety (Bridge-to-bridge). Ships >20 metres in length maintain a listening watch on this channel in US waters. |
| 14 | 14 | 156.700 | 156.700 | x | Port operations. VTS in selected areas. |
| 15 | 15 | - | 156.750 | x | Environmental (Receive only). Used by Class 'C' EPIRBs. |
| 16 | 16 | 156.800 | 156.80 0 | x | International Distress, Safety and Calling. Ships required to carry radio, USCG, and most coast stations maintain a listening watch on this channel. |
| 17 | 17 | 156.850 | 156.85 0 | x | State Control. |
| 1018 | 18A | 156.900 | 156.90 0 | x | Commercial. VDSMS. |
| 1019 | 19A | 156.950 | 156.95 0 | x | Commercial. VDSMS. |
| 20 | 20 | 157.000 | 161.600 | | Port operations (duplex). |
| 1020 | 20A | 157.000 | 157.00 0 | x | Port operations. |
| 1021 | 21A | 157.050 | 157.050 | x | US Coast Guard only. |
| 1022 | 22A | 157.100 | 157.100 | x | Coast Guard Liaison and Maritime Safety Information Broadcasts. Broadcasts announced on channel 16. |
| 1023 | 23A | 157.150 | 157.150 | x | US Coast Guard only. |
| 24 | 24 | 157.200 | 161.800 | | Public correspondence (Marine operator). |
| 25 | 25 | 157.250 | 161.850 | | Public correspondence (Marine operator). |
| 26 | 26 | 157.300 | 161.900 | | Public correspondence (Marine operator). |
| 27 | 27 | 157.350 | 161.950 | | Public correspondence (Marine operator). |
| 28 | 28 | 157.400 | 162.00 0 | | Public correspondence (Marine operator). |
| 1063 | 63A | 156.175 | 156.175 | x | Port operations and commercial VTS, Available only in New Orleans / Lower Mississippi area. |
| 1065 | 65A | 156.275 | 156.275 | x | Port operations. |
| 1066 | 66A | 156.325 | 156.325 | x | Port operations. |
| 67 | 67 | 156.375 | 156.375 | x | Commercial. Used for bridge-to-bridge communications in lower Mississippi river (Intership only). |
| 68 | 68 | 156.425 | 156.425 | x | Non-commercial. VDSMS. |
| 69 | 69 | 156.475 | 156.475 | x | Non-commercial. VDSMS. |
| 71 | 71 | 156.575 | 156.575 | x | Non-commercial. VDSMS. |
| 72 | 72 | 156.625 | 156.62 5 | x | Non-commercial (Intership only). VDSMS. |

| (New) CH No. | (Old) CH No. | TX Freq (MHz) | RX Freq (MHz) | Single Freq | Use |
|-----------------|-----------------|------------------|---------------------|----------------|---------------------------------------------------------------|
| 73 | 73 | 156.675 | 156.675 | x | Port operations. |
| 74 | 74 | 156.725 | 156.725 | x | Port operations. |
| 77 | 77 | 156.875 | 156.875 | x | Port operations (Intership only). |
| 1078 | 78A | 156.925 | 156.925 | x | Non-commercial. VDSMS. |
| 1079 | 79A | 156.975 | 156.975 | x | Commercial. Non-commercial in Great Lakes only). VDSMS. |
| 1080 | 80A | 157.025 | 157.025 | x | Commercial. Non-commercial in Great Lakes only). VDSMS. |
| 1081 | 81A | 157.075 | 157.075 | x | US Government only – Environmental protection operations. |
| 1082 | 82A | 157.125 | 157.125 | x | US Government only. |
| 1083 | 83A | 157.175 | 157.175 | x | US Coast Guard only. |
| 84 | 84 | 157.225 | 161.825 | | Public correspondence (Marine operator). VDSMS. |
| 85 | 85 | 157.275 | 161.875 | | Public correspondence (Marine operator). VDSMS. |
| 86 | 86 | 157.325 | 161.925 | | Public correspondence (Marine operator). VDSMS. |
| 87 | 87 | 157.375 | 161.975 | | Public correspondence (Marine operator). VDSMS. |
| 88 | 88 | 157.425 | 157.425 | | Commercial, Intership only. VDSMS. |

Please be aware that:

- Recreational boaters normally use channels listed as Non-commercial: 68, 69, 71, 72 1078.
- Channel 70 is used exclusively for DSC and is not available for regular voice communications.
- Channels 75 and 76 are reserved as guards bands for channel 16 and are not available for regular voice communications.

Note:

1. Four digit channels indicate simplex use of the ship station transmit side of an international semi-duplex channel. Operations are different from that of international operations on that channel.
2. Channel 13 should be used to contact a ship when there is danger of collision. All ships of length 20 metres or greater are required to guard VHF channel 13, in addition to VHF channel 16, when operating within US territorial waters.
3. Channel 15 is receive only.
4. Channel 16 is used for calling other stations or for distress calls.
5. Channel 17 and channel 77 have a fixed power output of 1 watt.
6. Channel 13 and channel 67 have an initial power output of 1 watt. User can temporarily override this restrictions to transmit at high power.
7. VDSMS (VHF Digital Small Message Services). Transmissions of short digital messages in accordance with RTCM Standard 12301.1 is allowed.

WX Channels (North America only)

| Weather Channel | Frequency in MHz |
|-----------------|------------------|
| WX1 | 162.550 |
| WX2 | 162.400 |

| Weather Channel | Frequency in MHz |
|-----------------|------------------|
| WX3 | 162.475 |
| WX4 | 162.425 |
| WX5 | 162.450 |
| WX6 | 162.500 |
| WX7 | 162.525 |
| WX8 | 161.650 |
| WX9 | 161.775 |
| WX10 | 163.275 |

Canadian Marine VHF Channels and Frequencies

Note:

Some of the channel numbers have recently changed. For completeness, both old and new numbers are shown in the table below.

| (New) CH No. | (Old) CH No. | TX Freq (MHz) | RX Freq (MHz) | Single Freq | Areas of operation | Use |
|--------------|--------------|---------------|---------------|-------------|----------------------------------|------------------------------------------------------------------------------------------------------------------------------------------------------------------------------------------------------------|
| 01 | 01 | 156.050 | 160.650 | | BCC | Public correspondence. |
| 02 | 02 | 156.100 | 160.700 | | BCC | Public correspondence. |
| 03 | 03 | 156.150 | 160.750 | | BCC | Public correspondence. |
| 1004 | 04A | 156.200 | 156.200 | x | BCC, EC | Intership, Ship/Shore, Commercial and Safety DFO / Canadian Coast Guard only in BCC area. Commercial fishing in EC area. |
| 1005 | 05A | 156.250 | 156.250 | x | AC, BCC, EC, GL, NL, INLD BC, WC | Ship movement. |
| 06 | 06 | 156.300 | 156.300 | x | All areas | Intership, Commercial, Non-Commercial and Safety Maybe used for search and rescue communications between ships and aircraft. |
| 1007 | 07A | 156.350 | 156.350 | x | AC, BCC, EC, GL, NL, INLD BC, WC | Intership, Ship/Shore and Commercial. |
| 08 | 08 | 156.400 | 156.400 | x | EC, INLD BC, WC | Intership, Commercial and Safety. Also assigned for Intership in the Lake Winnipeg area. |
| 09 | 09 | 156.450 | 156.450 | x | AC, INLD PRA, BCC | Intership, Ship/Shore, Commercial, Non-commercial, Safety and Ship movement. Commercial – BCC area. May be used to communicate with aircraft and helicopters in predominantly maritime support operations. |

| (New) CH No. | (Old) CH No. | TX Freq (MHz) | RX Freq (MHz) | Single Freq | Areas of op- eration | Use |
|--------------------|--------------------|---------------------|---------------------|----------------|-------------------------------------------------|------------------------------------------------------------------------------------------------------------------------------------------------------------------------------------------------------------------------------|
| 10 | 10 | 156.50 0 | 156.50 0 | x | AC, BCC, GL | Intership, Ship/Shore, Commercial, Non-commercial, Safety and Ship movement. Commercial — BCC area. May also be used for communications with aircraft engaged in coordinated search and rescue and antipollution operations. |
| 11 | 11 | 156.55 0 | 156.55 0 | x | AC, BCC, GL | Intership, Ship/Shore, Commercial, Non-commercial and Ship movement. VTS — BCC area. Also used for pilotage purposes. |
| 12 | 12 | 156.60 0 | 156.60 0 | x | AC, BCC, GL, WC | Intership, Ship/Shore, Commercial, Non-commercial and Ship movement. VTS — BCC area. Port operations and pilot information and messages. |
| 13 | 13 | 156.65 0 | 156.65 0 | x | AC, BCC, EC, GL, NL, INLD BC, WC | Intership, Commercial, Non-commercial and Ship movement. VTS — BCC area. Bridge-to-bridge navigational traffic. |
| 14 | 14 | 156.70 0 | 156.70 0 | x | AC, BCC, GL | Intership, Ship/Shore, Commercial, Non-commercial and Ship movement. VTS — BCC area. Port operations and pilot information and messages. |
| 15 | 15 | 156.75 0 | 156.75 0 | x | AC, BCC, EC, GL, NL, INLD BC, WC | Intership, Ship/Shore, Commercial, Non-commercial and Ship movement. Port operations and Ship movement — BCC area. All operations limited to 1 watt maximum power. May also be used for on-board communications. |
| 16 | 16 | 156.80 0 | 156.80 0 | x | All areas | International distress, safety and calling. |
| 17 | 17 | 156.85 0 | 156.85 0 | x | AC, BCC, EC, GL, NL, INLD BC, WC | Intership, Ship/Shore, Commercial, Non-commercial and Ship movement. Port operations and Ship movement — BCC area. All operations limited to 1 watt maximum power. May also be used for on-board communications. |
| 1018 | 18A | 156.90 0 | 156.90 0 | x | AC, BCC, EC, GL, NL, INLD BC, WC | Intership, Ship/Shore and Commercial. Towing — BCC area. |
| 1019 | 19A | 156.95 0 | 156.95 0 | x | All areas | Intership and Ship/Shore. DFO / Canadian Coast Guard. Pacific Pilots — BCC area. |
| 20 | 20 | 157.00 | 161.60 0 | | AC, BCC, EC, GL, NL, INLD BC, WC | Ship/Shore, Safety and Ship movement. Port operations only with 1 watt maximum power. |
| 1021 | 21A | 157.05 0 | 157.05 0 | x | All areas | Intership and Ship/Shore. DFO / Canadian Coast Guard only. |
| 2021 | 21B | - | 161.65 0 | x | All areas | Safety Continuous Marine Broadcast (CMB) service. |

| (New) CH No. | (Old) CH No. | TX Freq (MHz) | RX Freq (MHz) | Single Freq | Areas of op- eration | Use |
|--------------------|--------------------|---------------------|---------------------|----------------|-------------------------------------------------|--------------------------------------------------------------------------------------------------------------------------------------------------------------------------------------------------------------------------------------------------------------------------------------|
| 1022 | 22A | 157.100 | 157.100 | x | All areas | Intership, Ship/Shore, Commercial and Non-commercial. For communications between Canadian Coast Guard and non-Canadian Coast Guard stations only. |
| 23 | 23 | 157.150 | 161.750 | | BCC, INLD BC | Ship/Shore and Public correspondence. |
| 2023 | - | - | 161.750 | x | GL | Safety Continuous Marine Broadcast (CMB) service. |
| 24 | 24 | 157.200 | 161.800 | | All areas | Ship/Shore and Public correspondence. |
| 25 | 25 | 157.250 | 161.850 | | BCC | Ship/Shore and Public correspondence. |
| 2025 | 25B | - | 161.850 | x | AC | Safety Continuous Marine Broadcast (CMB) service. |
| 26 | 26 | 157.300 | 161.900 | | All areas | Safety and Public correspondence. |
| 27 | 27 | 157.350 | 161.950 | | AC, BCC, GL | Ship/Shore and Public correspondence. |
| 28 | 28 | 157.400 | 162.00 | | BCC | Ship/Shore, Safety and Public correspondence. |
| 2028 | 28B | - | 162.000 | x | AC, GL | Safety Continuous Marine Broadcast (CMB) service. |
| 60 | 60 | 156.025 | 160.625 | | BCC | Ship/Shore and Public correspondence. |
| 1061 | 61A | 156.075 | 156.075 | x | BCC | Intership, Ship/Shore and Commercial DFO / Canadian Coast Guard only in BCC area. Commercial fishing only in EC area. |
| 1062 | 62A | 156.125 | 156.125 | x | BCC, EC | Intership, Ship/Shore and Commercial DFO / Canadian Coast Guard only in BCC area. Commercial fishing only in EC area. |
| 1063 | | 156.175 | 156.175 | x | BCC | Intership, Ship/Shore and Commercial. Tow boats — BCC area. |
| 64 | 64 | 156.225 | 160.825 | | BCC | Ship/Shore and Public correspondence. |
| 1064 | 64A | 156.225 | 156.225 | x | EC | Intership, Ship/Shore and Commercial Commercial fishing only. |
| 1065 | 65A | 156.275 | 156.275 | x | All areas | Intership, Ship/Shore, Safety, Commercial and Non-commercial. Search and rescue and antipollution operations on the Great Lakes. Towing on the Pacific coast. Port operations only in the St. Lawrence river area with 1 watt maximum power. Intership in INLD PRA area. |
| 1066 | 66A | 156.325 | 156.325 | x | AC, BCC, EC, GL, NL, INLD BC, WC | Intership, Ship/Shore, Safety, Commercial and Non-commercial. Port operations only in the St. Lawrence river / Great Lakes areas with 1 watt maximum power. 1 watt marine channel in BCC area. |

| (New) CH No. | (Old) CH No. | TX Freq (MHz) | RX Freq (MHz) | Single Freq | Areas of op- eration | Use |
|--------------------|--------------------|---------------------|---------------------|----------------|-------------------------------------------------|-----------------------------------------------------------------------------------------------------------------------------------------------------------------------------------------------------------------------------------------------------------------------|
| 67 | 67 | 156.37 5 | 156.37 5 | x | All areas | Intership Ship/Shore, Safety, Commercial and Non-commercial. May also be used for communications with aircraft engaged in coordinated search and rescue and antipollution operations. Commercial fishing only in EC and INLD PRA areas. Pleasure craft — BCC area. |
| 68 | 68 | 156.42 5 | 156.42 5 | x | All areas | Intership, Ship/Shore and Non-commercial. For marinas, yacht clubs and pleasure craft. |
| 69 | 69 | 156.47 5 | 156.47 5 | x | AC, BCC, EC, GL, NL, INLD BC, WC | Intership, Ship/Shore, Commercial and Non-commercial. Commercial fishing only — EC area. Pleasure craft — BCC area. |
| 71 | 71 | 156.57 5 | 156.57 5 | x | AC, BCC, EC, GL, NL, INLD BC, WC | Intership, Ship/Shore, Safety, Commercial,, Non-commercial and Ship movement. Ship movement — BCC area. Marinas and yacht clubs — EC area and on Lake Winnipeg. |
| 72 | 72 | 156.62 5 | 156.62 5 | x | BCC, EC | Intership, Commercial and Non-commercial May be used to communicate with aircraft and helicopters in predominantly maritime support operations. Pleasure craft — BCC area. |
| 73 | 73 | 156.67 5 | 156.67 5 | x | All areas | Intership, Ship/Shore, Safety, Commercial and Non-commercial. May also be used for communications with aircraft engaged in coordinated search and rescue and antipollution operations. Commercial fishing only in EC and INLD PRA areas. |
| 74 | 74 | 156.72 5 | 156.72 5 | x | BCC, EC | Intership, Ship/Shore, Commercial, Non-commercial and Ship movement. VTS and Ship movement — BCC area. |
| 75 | | 156.77 5 | 156.77 5 | x | All areas | Intership, Ship/Shore, Commercial and Ship movement. Simplex port operation, ship movement and navigation related communication only. 1 watt maximum power. |
| 76 | | 156.82 5 | 156.82 5 | x | All areas | Intership, Ship/Shore, Commercial and Ship movement. Simplex port operation, ship movement and navigation related communication only. 1 watt maximum power. |
| 77 | 77 | 156.87 5 | 156.87 5 | x | AC, BCC, EC, GL, NL, INLD BC, WC | Intership, Ship/Shore, Safety and Ship movement. Pilotage BCC area, 25 watts. Port operations only in the St. Lawrence River/Great Lakes areas with 1 watt maximum power. |
| 1078 | 78A | 156.92 5 | 156.92 5 | x | BCC, EC | Intership, Ship/Shore and Commercial. Fishing industry — BCC area. |
| 1079 | 79A | 156.97 5 | 156.97 5 | x | BCC, EC | Intership, Ship/Shore and Commercial. Fishing industry — BCC area. |
| 1080 | 80A | 157.02 5 | 157.02 5 | x | BCC, EC | Intership, Ship/Shore and Non-commercial. Whale watching — BCC area. |

| (New) CH No. | (Old) CH No. | TX Freq (MHz) | RX Freq (MHz) | Single Freq | Areas of op- eration | Use |
|--------------------|--------------------|---------------------|---------------------|----------------|-------------------------------------------------|---------------------------------------------------------------------------------------------------------------------------|
| 1081 | 81A | 157.07 5 | 157.07 5 | x | AC, BCC, EC, GL, NL, INLD BC, WC | Intership, Ship/Shore and Safety. DFO / Canadian Coast Guard use only. |
| 1082 | 82A | 157.125 | 157.12 5 | x | AC, BCC, EC, GL, NL, INLD BC, WC | Intership and Ship/Shore. DFO / Canadian Coast Guard use only. |
| 1083 | 83A | 157.175 | 157.17 5 | x | BCC, EC | Intership and Ship/Shore DFO / Canadian Coast Guard and other government agencies. |
| 2083 | 83B | - | 161.77 5 | x | AC, BCC, GL | Safety Continuous Marine Broadcast (CMB) service. |
| 84 | 84 | 157.22 5 | 161.82 5 | | BCC | Ship/Shore and Public correspondence. |
| 85 | 85 | 157.27 5 | 161.87 5 | | AC, BCC, GL ,NL | Ship/Shore and Public correspondence. |
| 86 | 86 | 157.32 5 | 161.92 5 | | BCC | Ship/Shore and Public correspondence. |
| 87 | 87 | 157.37 5 | 157.37 5 | x | AC, BCC, GL, NL | Intership, Non-commercial and Ship movement. Port operation and ship movement — EC area. Pleasure craft — BCC area. |
| 88 | 88 | 157.42 5 | 157.42 5 | x | AC, BCC, GL, NL | Intership, Commercial and Ship movement. Port operation and ship movement — BCC area. |

Area of operation:

- **AC** — Atlantic Coast, Gulf and St. Lawrence River up to and including Montreal.
- **BCC** — British Columbia Coast (Pacific Coast).
- **EC** — East Coast: includes NL, AC, GL and Eastern Arctic areas.
- **GL** — Great Lakes: includes St. Lawrence above Montreal.
- **NL** — Newfoundland and Labrador.
- **WC** — West Coast: includes BCC, Western Arctic and Athabasca-Mackenzie Watershed areas.
- **INLD BC** — Inland waters of BC and the Yukon
- **INLD PRA** — Inland waters of MB, SK and AB

Note:

1. Four digit channels indicate simplex use of the ship station transmit side of an international semi-duplex channel. Operations are different from that of international operations on that channel.
2. Channel 16 is used for calling other stations or for distress calls.
3. Channel 70 is used exclusively for Digital Selective Calling and is not available for regular voice communications.

Appendix E Phonetic alphabet

To help make call letters more clearly understood, and to assist in spelling out similar sounding or unfamiliar word, radiotelephone users employ the international phonetic alphabet.

| | | | |
|----------|---------|----------|----------|
| A | ALPHA | N | NOVEMBER |
| B | BRAVO | O | OSCAR |
| C | CHARLIE | P | PAPA |
| D | DELTA | Q | QUEBEC |
| E | ECHO | R | ROMEO |
| F | FOXTROT | S | SIERRA |
| G | GOLF | T | TANGO |
| H | HOTEL | U | UNIFORM |
| I | INDIA | V | VICTOR |
| J | JULIET | W | WHISKEY |
| K | KILO | X | X-RAY |
| L | LIMA | Y | YANKEE |
| M | MIKE | Z | ZULU |

Appendix F Prowords

Prowords can be used to simplify and speed up radio communications.

| Proword | Meaning |
|------------------------|---------------------------------------------------------------------------------|
| ACKNOWLEDGE | Have you received and understood? |
| CONFIRM | Is that correct? |
| CORRECTION | An error has been made? |
| I SAY AGAIN | I repeat (e.g. important information). |
| I SPELL | Phonetically spelling of the word. |
| OUT | End of communication. |
| OVER | I have completed this part of the message and am inviting you to reply. |
| RECEIVED | Receipt acknowledgement. |
| SAY AGAIN | Repeat your message. |
| STATION CALLING | Used when a station is uncertain of the identity of a station which is calling. |

Index

A

| | |
|-----------------------------|----------|
| Accessories | 192 |
| Wired | 192 |
| Wireless | 192 |
| Additional components | 21 |
| AIS receiver | 152 |
| Applicable products | 21 |
| ATIS | |
| Enabling/Disabling | 111, 151 |
| ATIS ID | 30, 110 |

B

| | |
|----------------------------|-----|
| Backlight adjustment | 100 |
| Bracket mounting | 47 |
| Brightness | |
| Adjustment | 100 |
| Shared | 101 |

C

| | |
|------------------------------------|---------|
| Cable bend radius | 64 |
| Cable protection | 64–65 |
| Cable routing | 34, 64 |
| Call log | 142 |
| Details | 142 |
| Types | 142 |
| Checking password | 121 |
| Cleaning | 164 |
| Compass safe distance | 35 |
| Compatible MFDs | 22–23 |
| Connecting SeaTalkng® cables | 77 |
| Connections | 69 |
| Bare wires | 65 |
| Battery | 70 |
| DeviceNet | 77 |
| Distribution panel | 71 |
| Fistmic (Front) | 74 |
| Fistmic (Rear) | 74 |
| General cabling guidance | 64 |
| Loud hailer | 86 |
| NMEA 0183 | 78 |
| NMEA 2000 | 77 |
| Passive speaker | 81 |
| Primary station | 68 |
| Ray53 | 66 |
| Ray63 | 67 |
| Ray73 | 67 |
| Raymic handset | 76 |
| SeaTalkng | 77 |
| Secondary station | 68, 76 |
| VHF antenna | 79 |
| Wire | 65 |
| Wireless handset | 84 |
| Wireless hub | 120 |
| Wireless speaker | 85, 123 |
| Contact details | 172 |
| Contrast adjustment | 100 |
| Controls | |
| Base station | 88 |
| Fistmic | 88 |

| | |
|------------------------|----|
| Raymic | 90 |
| Wired handset | 90 |
| Wireless handset | 90 |

D

| | |
|-------------------------------------------|----------|
| Declaration of Conformity | 15 |
| DeviceNet cables | 195 |
| Digital Selective Calling, <i>See</i> DSC | |
| Dimensions | |
| Active speaker | 44 |
| Fistmic | 42 |
| Passive speaker | 44 |
| Ray53 | 40 |
| Ray63 | 41 |
| Ray73 | 41 |
| Raymic | 43 |
| Wired handset | 43 |
| Wireless hub | 44 |
| Display set-up | 154 |
| Distress call | 128, 130 |
| Cancelling | 131–132 |
| Documentation | 18 |
| Drilling | |
| Product holes | 49, 51 |
| DSC set-up | 144 |

E

| | |
|-------------------------------------|----|
| Electromagnetic Compatibility | 37 |
| EMC | 37 |

F

| | |
|-------------------------------------|--------|
| FAQs | 175 |
| Front bezel | |
| Attaching | 53 |
| Fuse rating, Wireless speaker | 83, 85 |

G

| | |
|----------------------------|-----|
| GNSS | |
| Antenna | 21 |
| Displayed data | 114 |
| Enabling/Disabling | 114 |
| Integrated | 114 |
| Internal | 114 |
| No position data | 114 |
| Position information | 114 |
| set-up | 114 |
| GPS, <i>See</i> GNSS | |
| Group call | 139 |
| Making | 139 |
| Receiving | 139 |

H

| | |
|------------------|----|
| Handset | |
| Power | 92 |
| Homescreen | 94 |

I

| | |
|-----------------------|-----|
| Individual call | 129 |
|-----------------------|-----|

| | |
|--------------------------------|-----|
| Making | 138 |
| Reason codes | 138 |
| Receiving | 138 |
| Installation | |
| Best practice | 73 |
| EMC guidelines | 37 |
| surface requirements | 34 |
| Ventilation | 34 |
| VHF antenna requirements | 36 |
| Intercom | 161 |
| Interference | |
| Compass | 35 |
| Electrical | 34 |
| RF | 34 |

K

| | |
|----------------------|-----|
| Knowledge base | 175 |
|----------------------|-----|

L

| | |
|----------------------------------|-------|
| Licensing | |
| Europe and ROW Requirement | 26 |
| ISED Requirement | 26 |
| Requirement | 26 |
| USA Requirement | 26 |
| LightHouse™ 3 | |
| Tips and Tricks | 175 |
| Location requirements | |
| GNSS | 35–36 |
| GPS | 35–36 |
| Wireless | 38 |
| Loud hailer | 159 |

M

| | |
|------------------------------|--------|
| Maintenance | 164 |
| Making designated call | 130 |
| Manual position | 114 |
| Mayday call | 131 |
| Menus | |
| Display set-up | 154 |
| DSC set-up | 144 |
| Fog | 158 |
| Hailer | 158 |
| Intercom | 158 |
| Main menu | 97 |
| Set-up | 153 |
| Wireless set-up | 124 |
| MMSI | 29 |
| Where to apply | 200 |
| MMSI number | 108 |
| Mounting | 50, 52 |
| Bracket | 47 |
| Fistmic | 55 |
| Handset | 55 |
| Hole covers | 49 |
| Hook plate | 55 |
| Options | 47 |
| Panel | 48, 51 |
| Pass-through panel kit | 58 |
| Product holes | 49, 51 |
| Ray53 | 48 |
| Ray63 | 51 |

| | |
|------------------------|----|
| Ray73 | 51 |
| Raymic | 55 |
| Wired handset | 56 |
| Wired speaker | 57 |
| Wireless handset | 62 |
| Wireless hub | 60 |
| Wireless speaker | 57 |
| MPE | 36 |

N

| | |
|------------------------|-----|
| Network | |
| Selection | 107 |
| NMEA | |
| Settings | |
| Baud rate | 107 |
| NMEA 0183 | |
| Sentences (PGNs) | 197 |
| NMEA 2000 | |
| PGNs | 198 |

O

| | |
|---------------------------|----|
| Optional components | 21 |
|---------------------------|----|

P

| | |
|--------------------------------|-----------|
| Panel mounting | 48, 50–52 |
| Parts supplied | |
| Ray53 | 24 |
| Ray63 | 25 |
| Ray73 | 25 |
| Phonebook | 141 |
| Adding entry | 141 |
| Delete entry | 141 |
| Updating entry | 141 |
| Position request | 140 |
| Automatic response | 140 |
| Making | 140 |
| Responding | 140 |
| Power | 69 |
| Battery connection | 70 |
| Distribution | 70 |
| Distribution panel | 71 |
| Grounding | 72 |
| Sharing a breaker | 71 |
| Power cable extension | 72 |
| Product | |
| Documentation | 18 |
| overview | 20 |
| Product recycling (WEEE) | 15 |
| Product support | 172 |

R

| | |
|------------------------------------------|----|
| Radio Frequency (RF) interference | 34 |
| Routine call, <i>See</i> Individual call | |

S

| | |
|-------------------|-----|
| Safety call | 128 |
| Making | 137 |
| Receiving | 137 |

| | |
|--------------------------------------------|-----|
| Scan mode | 147 |
| Setting..... | 147 |
| SeaTalkng cables | 194 |
| SeaTalkng documentation | 18 |
| SeaTalkng® | |
| Connecting cables | 77 |
| Securing cables | 64 |
| Service Center..... | 172 |
| Servicing..... | 164 |
| Set-up menu | 153 |
| Shared brightness | 101 |
| Software update | 31 |
| Software version..... | 31 |
| Spares | 193 |
| Specification | |
| Battery | 187 |
| Charger..... | 188 |
| Wired (Passive) speaker..... | 185 |
| Wired handset (Raymic) | 184 |
| Wireless (Active) speaker..... | 189 |
| Wireless handset | 187 |
| Wireless handset charging holster | 188 |
| Wireless hub | 186 |
| Station priority | 116 |
| Status bar | 95 |
| Strain relief, <i>See</i> Cable protection | |
| Support forum | 175 |
| Switching power output..... | 113 |

T

| | |
|-----------------------------------------------|----------|
| Technical specification | 177 |
| Ray53..... | 178 |
| Ray60 | 180 |
| Ray73..... | 182 |
| Technical support..... | 172, 175 |
| Test call | 143 |
| Making | 143 |
| Receiving | 143 |
| Thermal breaker rating, Wireless speaker..... | 83, 85 |
| Time | |
| Format..... | 115 |
| Offset | 115 |
| Tools required | 46 |
| Training courses..... | 175 |
| Transmit power..... | 113 |
| Troubleshooting | 166 |
| GNSS | 170 |
| GPS..... | 170 |
| Power..... | 167 |
| Trunnion mounting | 47 |

U

| | |
|-------------------|-----|
| Urgency call..... | 128 |
| Making | 136 |
| Receiving | 136 |

V

| | |
|-------------------|-----|
| VHF antenna | 21 |
| VHF channels | |
| Canada | 207 |

| | |
|-------------------------------|-----|
| International..... | 201 |
| Private (Europe) | 204 |
| United States | 204 |
| Weather (North America) | 206 |
| Video Gallery..... | 175 |

W

| | |
|--------------------------------|----------|
| Warranty | 172 |
| Watch mode | 146 |
| Dual watch | 146 |
| Setting..... | 146 |
| Triple watch | 146 |
| Water ingress | 34 |
| Waterproofing | 34 |
| WEEE Directive..... | 15 |
| Wireless | |
| Channel | 39 |
| Channel changing..... | 121 |
| Interference | 38 |
| Password changing | 121 |
| Wireless charging..... | 118 |
| Wireless components..... | 22 |
| Wireless handset stations..... | 118 |
| Wireless hub..... | 121 |
| Antenna extension..... | 61 |
| Name change | 121 |
| Pairing..... | 120 |
| Password | 120, 124 |
| SSID change | 121 |
| Wireless hub settings | 124 |
| Wireless menu..... | 124 |
| Wireless set-up..... | 124 |
| Wireless speaker | |
| Disconnecting..... | 123 |
| Pairing..... | 123 |
| WirelessPre-installation | |
| Analyzer | 39 |
| Site survey | 39 |



Raymarine

Marine House, Cartwright Drive, Fareham, Hampshire.
PO15 5RJ. United Kingdom.

Tel: +44 (0)1329 246 700

www.raymarine.com

Raymarine®

a brand by  **FLIR®**