

Raymarine®



HYPERVERSION™ HV-100

Installation instructions

English (en-US)
Date: 01-2019
Document number: 87362-1
© 2019 Raymarine UK Limited

Trademark and patents notice

Raymarine, Tacktick, Clear Pulse, Truzoom, SeaTalk, SeaTalk^{hs}, SeaTalkng, and **Micronet**, are registered or claimed trademarks of Raymarine Belgium.

FLIR, LightHouse, DownVision, SideVision, RealVision, HyperVision, Dragonfly, Element, Quantum, Axiom, Instalert, Infrared Everywhere, The World's Sixth Sense and **ClearCruise** are registered or claimed trademarks of FLIR Systems, Inc.

All other trademarks, trade names, or company names referenced herein are used for identification only and are the property of their respective owners.

This product is protected by patents, design patents, patents pending, or design patents pending.

Fair Use Statement

You may print no more than three copies of this manual for your own use. You may not make any further copies or distribute or use the manual in any other way including without limitation exploiting the manual commercially or giving or selling copies to third parties.

Software updates



Check the Raymarine website for the latest software releases for your product.
www.raymarine.com/software

Product documentation



The latest versions of all English and translated documents are available to download in PDF format from the website: www.raymarine.com/manuals.
Please check the website to ensure you have the latest documentation.

Copyright ©2019 Raymarine UK Ltd. All rights reserved.

Contents

Chapter 1 Important information	7
Water ingress	7
Disclaimer	7
Declaration of conformity.....	8
Warranty registration.....	8
Product disposal	8
IMO and SOLAS	8
Technical accuracy.....	8
Chapter 2 Document and product information.....	9
2.1 Product documentation.....	10
Operation instructions	10
Document illustrations	10
2.2 Applicable products.....	11
2.3 Product overview	12
2.4 Required additional components.....	13
Compatible displays	13
2.5 Parts supplied.....	14
Chapter 3 Installation	15
3.1 Tools required	16
Anti-fouling	17
3.2 Pre-installation test.....	18
Testing the transducer.....	18
3.3 Selecting a location.....	19
Warnings and cautions	19
Location requirements.....	19
EMC installation guidelines.....	20
HV-100 product dimensions	20
3.4 Mounting.....	22
Transducer assembly.....	22
Mounting the transom bracket.....	23
Mounting the transducer assembly	24
Mounting the escutcheon plate	25
Testing and adjusting the transducer	26
Finalizing the transducer mounting	28
Chapter 4 Connections.....	31
4.1 General cabling guidance	32
Cable types and length.....	32
Strain relief.....	32
Cable shielding.....	32

4.2 Cable routing	33
HyperVision™ transducer extension cable	33
4.3 Making connections	34
Chapter 5 System checks and troubleshooting.....	35
5.1 Operation instructions	36
5.2 Troubleshooting	37
Sonar troubleshooting	37
Resetting the sonar.....	39
Chapter 6 Maintenance	41
6.1 Routine checks	42
6.2 Transducer cleaning	43
6.3 Re-applying anti-fouling paint.....	44
Chapter 7 Technical support.....	45
7.1 Raymarine product support and servicing	46
7.2 Learning resources	48
Chapter 8 Technical specification.....	49
8.1 Technical specification	50
Physical specification.....	50
Environmental specification.....	50
HyperVision™ technical specification	50
Conformance specification	50
Chapter 9 Spares and accessories	51
9.1 Spares.....	52
9.2 Accessories.....	53

Chapter 1: Important information



Warning: Product installation and operation

- This product must be installed and operated in accordance with the instructions provided. Failure to do so could result in personal injury, damage to your vessel and/or poor product performance.
- Raymarine recommends certified installation by a Raymarine approved installer. A certified installation qualifies for enhanced product warranty benefits. Contact your Raymarine dealer for further details, and refer to the separate warranty document packed with your product.



Warning: Anti-fouling

- Failure to comply with the provided anti-fouling and transducer cleaning instructions may affect your product warranty.
- Only use water-based anti-fouling paint.
- Do NOT use keytone or copper-based anti-fouling paint.



Warning: Marine-grade sealant

Only use marine-grade neutral cure polyurethane sealants. Do NOT use sealants containing acetate or silicone, which can cause damage to plastic parts.



Warning: High voltages

This product may contain high voltages. Do NOT remove any covers or otherwise attempt to access internal components, unless specifically instructed in the documentation provided.



Warning: Switch off power supply

Ensure the vessel's power supply is switched OFF before starting to install this product. Do NOT connect or disconnect equipment with the power switched on, unless instructed in this document.



Warning: Transducer operation

Only test and operate the transducer in the water. Do NOT operate out of water as overheating may occur.

Caution: Service and maintenance

This product contains no user serviceable components. Please refer all maintenance and repair to authorized Raymarine dealers. Unauthorized repair may affect your warranty.

Water ingress

Water ingress disclaimer

Although the waterproof rating capacity of this product meets the stated water ingress protection standard (refer to the product's *Technical Specification*), water intrusion and subsequent equipment failure may occur if the product is subjected to high-pressure washing. Raymarine will not warrant products subjected to high-pressure washing.

Disclaimer

Raymarine does not warrant that this product is error-free or that it is compatible with products manufactured by any person or entity other than Raymarine.

Raymarine is not responsible for damages or injuries caused by your use or inability to use the product, by the interaction of the product with products manufactured by others, or by errors in information utilized by the product supplied by third parties.

Declaration of conformity

FLIR Belgium BVBA declares that the following products are in compliance with the EMC Directive 2014/30/EU:

- HV-100 HyperVision™ plastic transom mount transducer, part number A80603

The original Declaration of Conformity certificate may be viewed on the relevant product page at www.raymarine.com.

Warranty registration

To register your Raymarine product ownership, please visit www.raymarine.com and register online.

It is important that you register your product to receive full warranty benefits. Your unit package includes a bar code label indicating the serial number of the unit. You will need this serial number when registering your product online. You should retain the label for future reference.

Product disposal

Dispose of this product in accordance with the WEEE Directive.

The Waste Electrical and Electronic Equipment (WEEE) Directive requires the recycling of waste electrical and electronic equipment which contains materials, components and substances that may be hazardous and present a risk to human health and the environment when WEEE is not handled correctly.

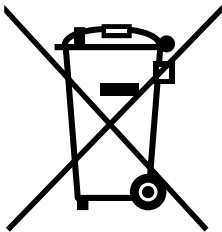

Equipment marked with the crossed-out wheeled bin symbol indicates that the equipment should not be disposed of in unsorted household waste.

Local authorities in many regions have established collection schemes under which residents can dispose of waste electrical and electronic equipment at a recycling center or other collection point.

For more information about suitable collection points for waste electrical and electronic equipment in your region, refer to the Raymarine website: www.raymarine.eu/recycling.



IMO and SOLAS

The equipment described within this document is intended for use on leisure marine boats and workboats NOT covered by International Maritime Organization (IMO) and Safety of Life at Sea (SOLAS) Carriage Regulations.

Technical accuracy

To the best of our knowledge, the information in this document was correct at the time it was produced. However, Raymarine cannot accept liability for any inaccuracies or omissions it may contain. In addition, our policy of continuous product improvement may change specifications without notice. As a result, Raymarine cannot accept liability for any differences between the product and this document. Please check the Raymarine website (www.raymarine.com) to ensure you have the most up-to-date version(s) of the documentation for your product.

Chapter 2: Document and product information

Chapter contents

- 2.1 Product documentation on page 10
- 2.2 Applicable products on page 11
- 2.3 Product overview on page 12
- 2.4 Required additional components on page 13
- 2.5 Parts supplied on page 14

2.1 Product documentation

The following documentation is applicable to your product:

All documents are available to download as PDFs from www.raymarine.com/manuals

Documentation

Description	Part number
HV-100 Transom Transducer Installation Instructions (this document)	87362
HV—100 Transom Transducer Mounting template	87376
Element™ HyperVision™ Basic Operation instructions. Includes basic operation instructions for the Sonar app on your display.	81384
Element™ HyperVision™ Advanced Operation instructions. Includes advanced operation instructions for the Sonar app on your display.	81388

Operation instructions

For detailed operation instructions for your product, refer to the documentation that accompanies your display.

All product documentation is available to download from the Raymarine website: www.raymarine.com/manuals.

Document illustrations

Your product and if applicable, its user interface may differ slightly from that shown in the illustrations in this document, depending on product variant and date of manufacture.

All images are provided for illustration purposes only.

2.2 Applicable products

Part number	Description
A80603	HV-100 HyperVision™ plastic transom mount transducer

2.3 Product overview

The HV-100 is a HyperVision™ transom mount plastic transducer. The transducer is compatible with HyperVision™ variant displays.

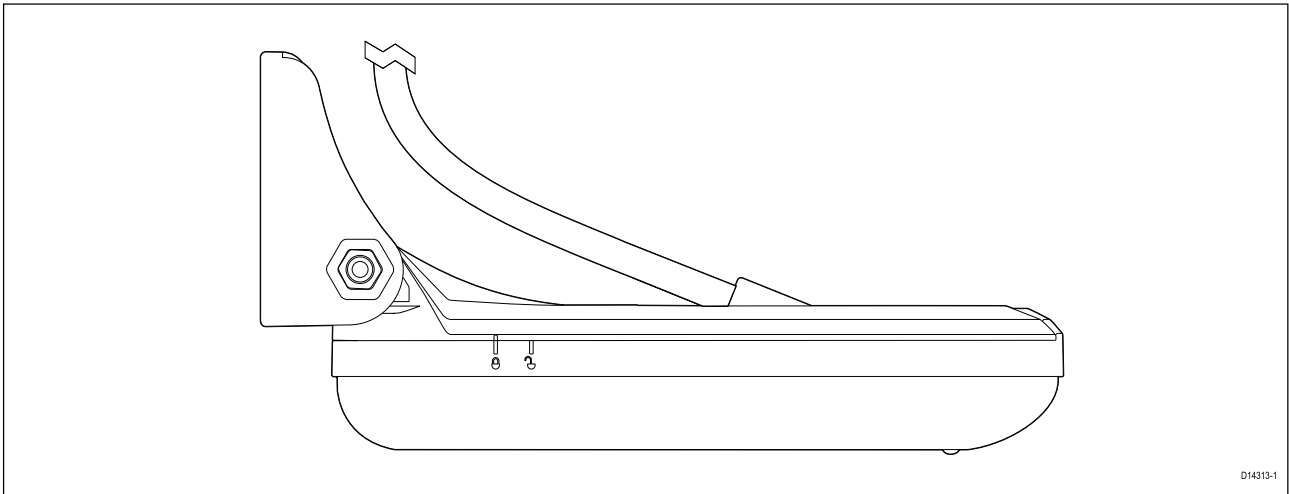

HyperVision™ transducers are capable of producing sonar images for:

- RealVision™ 3D (Hyper 1.2 MHz)
- RealVision™ 3D (Standard 350 kHz)
- SideVision™ (Hyper 1.2 MHz)
- SideVision™ (Standard 350 kHz)
- DownVision™ (Hyper 1.2 MHz)
- DownVision™ (Standard 350 kHz)
- Conical high CHIRP (200 kHz)

2.4 Required additional components

This product forms part of a system of electronics and requires the following additional components for full operation.

- Compatible HyperVision™ sonar-capable device. Refer to [Compatible displays](#), for a list of compatible products.
- For longer cable runs, a transducer extension cable will also be required. Refer to [HyperVision™ transducer extension cable](#), for suitable cables.

Compatible displays

Compatible displays are listed below.

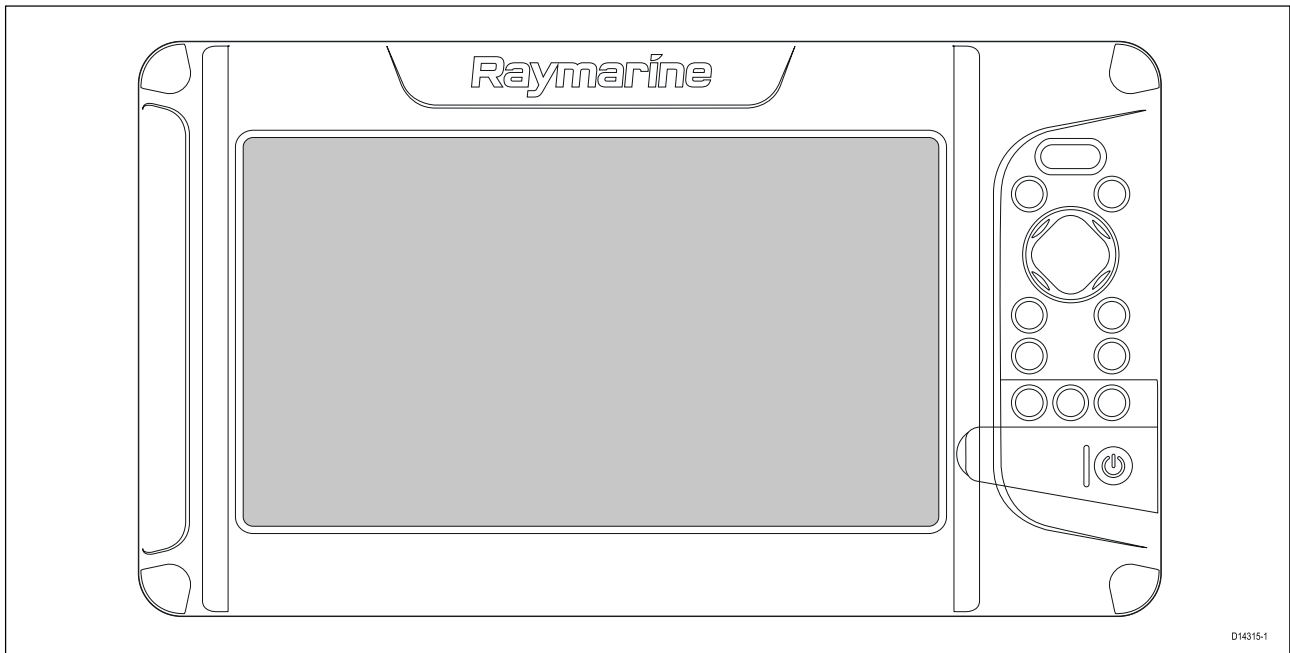

Part number	Description
E70532	Element 7 HV
E70534	Element 9 HV
E70536	Element 12 HV

2.5 Parts supplied

The following parts are supplied with your product:

Unpack your product carefully to prevent damage or loss of parts. Check the box contents against the list below. Retain the packaging and documentation for future reference.

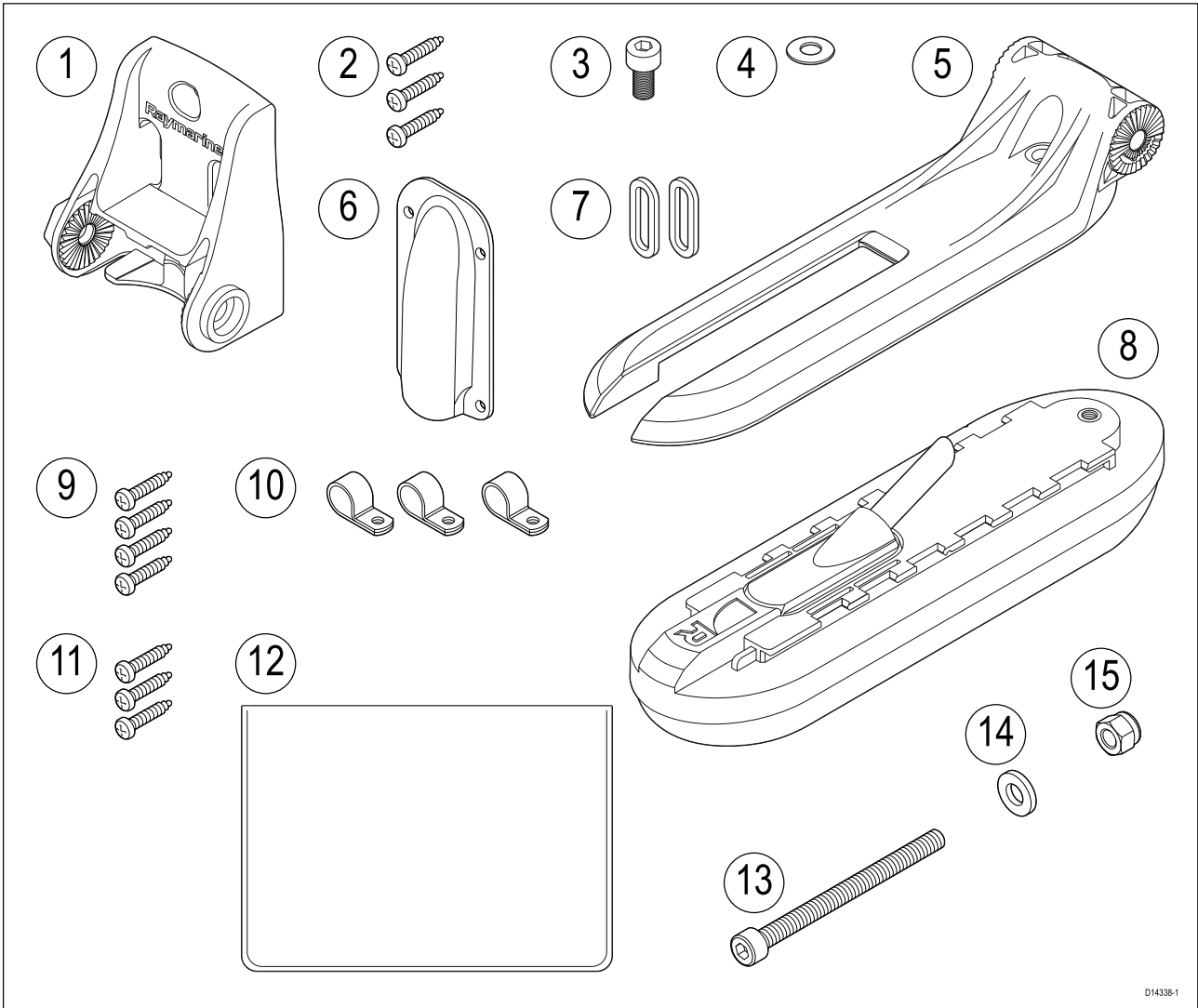

D14338-1

1	Transom bracket
2	3 x bracket fixing screws (4.2x19 mm A4 stainless steel)
3	M5x10 hex bolt (A4 stainless steel)
4	M5 washer (A4 stainless steel)
5	Hanger bracket
6	Escutcheon plate (used when routing cable through transom or a bulkhead)
7	2 x adjustment slot washers
8	Transducer with 6 m (19.69 ft) fitted cable
9	4 x escutcheon plate fixings (#8x13 SUS316)
10	3 x cable clips
11	3 x cable clip fixings (#8x13 SUS316)
12	Documentation pack
13	M6x70 hex bolt (A4 stainless steel)
14	M6 washer (A4 stainless steel)
15	M6 locking nut

Chapter 3: Installation

Chapter contents

- 3.1 Tools required on page 16
- 3.2 Pre-installation test on page 18
- 3.3 Selecting a location on page 19
- 3.4 Mounting on page 22

3.1 Tools required

The following tools are required to install your transducer:

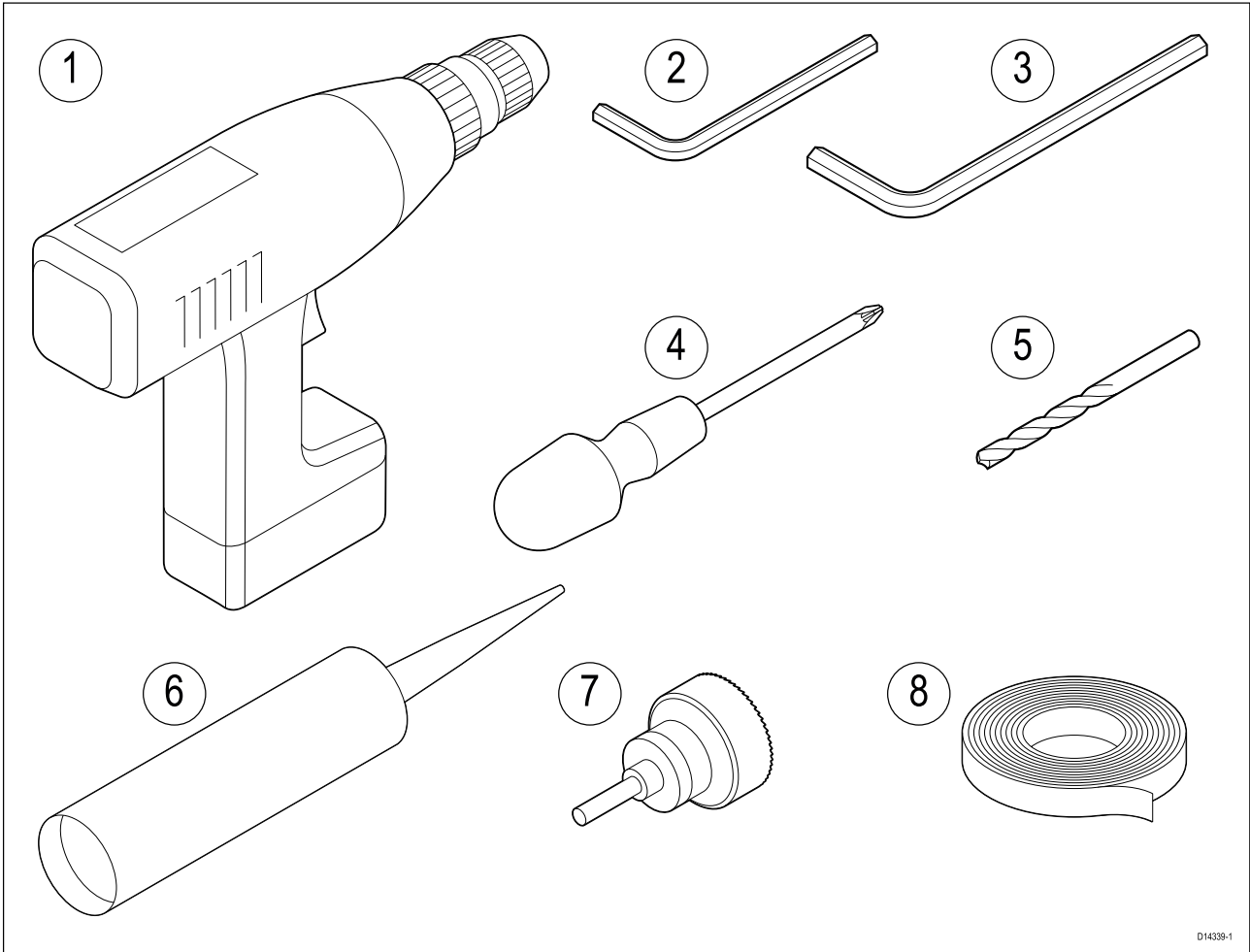

1. Power drill
2. 4 mm hex wrench (Allen key)
3. 5 mm hex wrench (Allen key)
4. Pozi-drive screw driver
5. Drill bit (suitable for pilot holes)
6. Marine grade sealant
7. 24 mm (15/16 in) or suitable size hole cutter (only required when routing the cable through a bulkhead or transom)
8. Masking / adhesive tape



Warning: Marine-grade sealant

Only use marine-grade neutral cure polyurethane sealants. Do NOT use sealants containing acetate or silicone, which can cause damage to plastic parts.

Anti-fouling

Where local regulations allow, it is recommended that you coat your transducer using a water-based anti-fouling paint. This will help prevent the build-up of organic growth, which can reduce transducer performance.

Important:

- Before applying water-based anti-fouling paint, check that local environmental rules and regulations do not prohibit the use of anti-fouling paint.
- Never use copper-based anti-fouling paint as this can impact transducer performance.
- Never use ketone-based anti-fouling paint as this can attack the transducer's plastic, damaging the transducer.
- Paint your transducer using a brush, do not use a spray can or a sponge roller as these methods can cause tiny air bubbles to be incorporated in the paint, which will also reduce transducer performance.

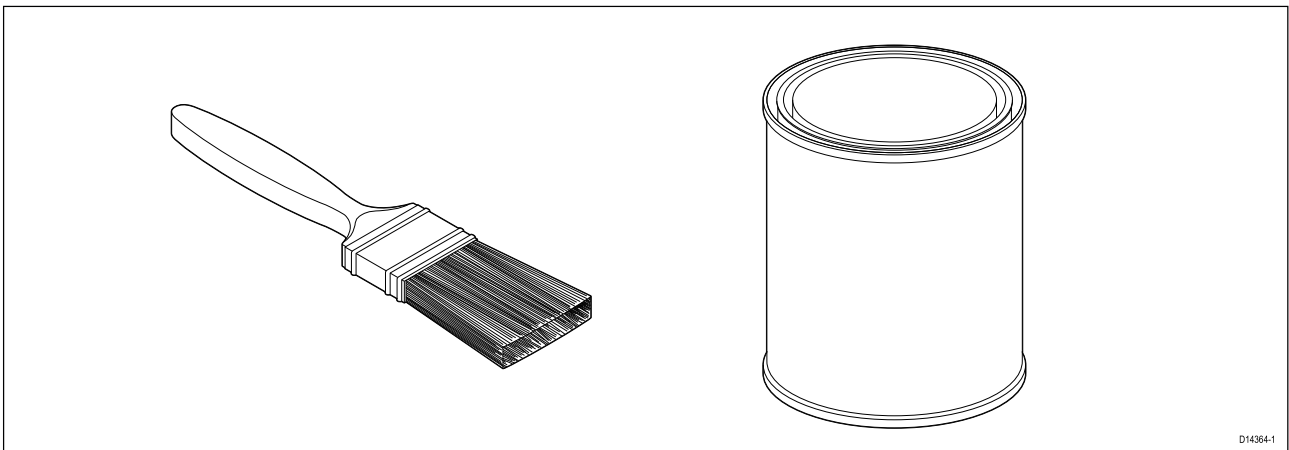

The anti-fouling paint should be applied in a thin and even coat covering all externally exposed transducer surfaces.

You should clean your transducer regularly and re-apply anti-fouling paint every 6 months, or sooner depending on how rapidly organic growth builds up.

Refer to [6.2 Transducer cleaning](#) for cleaning guidance.

For instructions on re-applying anti-fouling paint, refer to [6.3 Re-applying anti-fouling paint](#)

3.2 Pre-installation test

Testing the transducer

Transducer operation should be checked before installation.

1. Connect the transducer to the transducer connection of a HyperVision™ compatible display (e.g. Element HV 9 display).
2. Fully submerge the transducer in water.
3. Power up your HyperVision™ display.

The first time the display is powered up, or after a factory reset has been performed, the startup wizard is displayed. Transducer selection is part of the boat details options in the startup wizard.

4. Open a Fishfinder (Sonar) app on your display.
5. If required, select the relevant transducer from the Transducer settings tab (**Menu > Transducer > Transducer**).
6. Check that accurate depth and temperature readings are displayed.
7. If you experience difficulties obtaining readings then contact Raymarine Technical Support.



Warning: Transducer operation

Only test and operate the transducer in the water. Do NOT operate out of water as overheating may occur.

Caution: Transducer cable

- Do NOT use the transducer cable to lift or suspend the transducer; always support the transducer body directly during installation.
- Do NOT cut, shorten, or splice the transducer cable.
- Do NOT remove the connector.

If the cable is cut, it cannot be repaired. Cutting the cable will also void the warranty.

3.3 Selecting a location

Warnings and cautions

Important: Before proceeding, ensure that you have read and understood the warnings and cautions provided in the [Chapter 1 Important information](#) section of this document.

Location requirements

The guidelines below should be followed when selecting a location for the transducer.

Note:
The transducer is not suitable for mounting on vessels where the transom is aft of the propeller(s).

For best performance the transducer must be installed in a location with the least turbulence and aeration. The most effective way to determine this is by checking the water flow around the transom whilst underway.

- Mount close to the keel (centerline), in a position where the transducer element will be fully submerged when the vessel is planing and turning.
- Mount a suitable distance from the propeller(s) to avoid wake.
- Mount in a location where no load will be applied to the transducer during launching, lifting, trailering and storage of the boat.

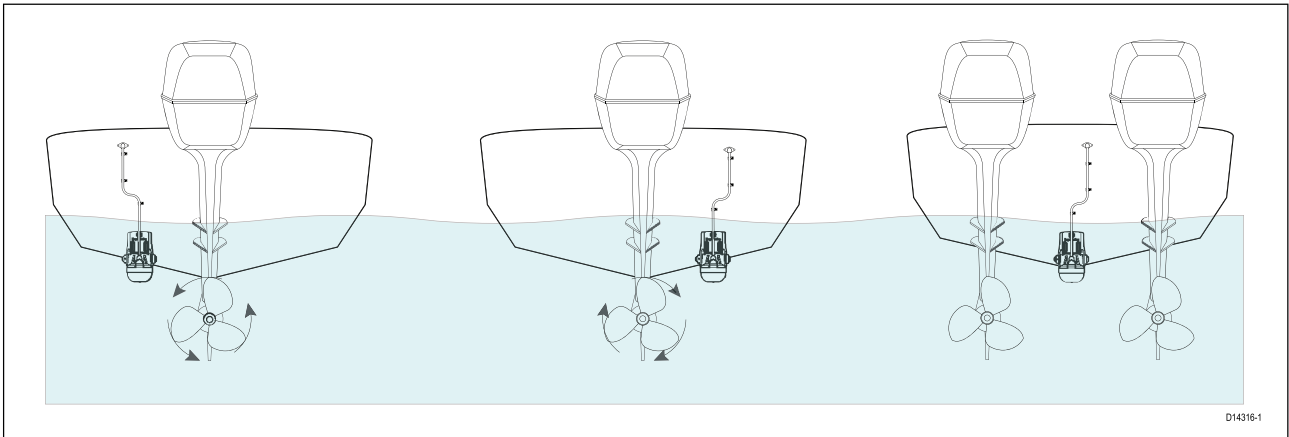

- For clockwise rotating propellers, mount the transducer on the starboard side, for counter-clockwise, mount on the port side.
- On a twin engine vessel mount the transducer between the engines.
- Turbulence can be caused by a number of other factors such as steps (1), ribs (2), rows of rivets (3) and strakes (4). The turbulence appears aft of these locations.

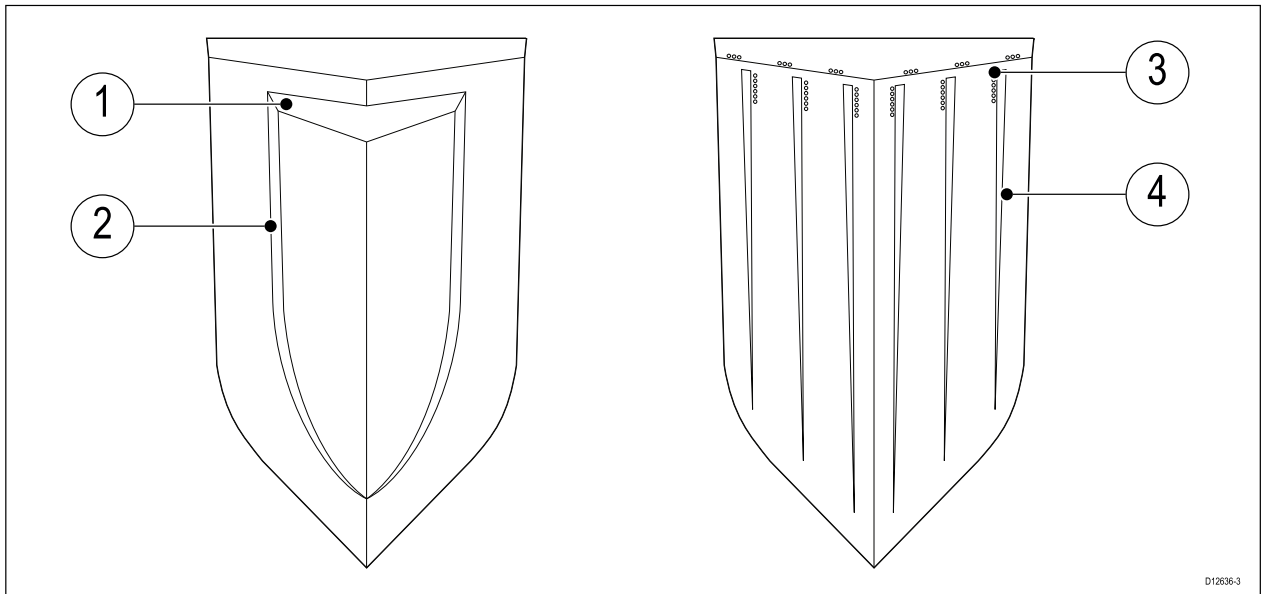

- Air trapped under the front of the vessel can travel under the hull and appear as aeration aft.

Note:

Optimum transducer location will vary depending on vessel type. Optimum transducer height and angle should be obtained by testing the transducer with the vessel in the water.

EMC installation guidelines

Raymarine equipment and accessories conform to the appropriate Electromagnetic Compatibility (EMC) regulations, to minimize electromagnetic interference between equipment and minimize the effect such interference could have on the performance of your system

Correct installation is required to ensure that EMC performance is not compromised.

Note: In areas of extreme EMC interference, some slight interference may be noticed on the product. Where this occurs the product and the source of the interference should be separated by a greater distance.

For **optimum** EMC performance we recommend that wherever possible:

- Raymarine equipment and cables connected to it are:
 - At least 1 m (3.3 ft) from any equipment transmitting or cables carrying radio signals e.g. VHF radios, cables and antennas. In the case of SSB radios, the distance should be increased to 2 m (6.6 ft).
 - More than 2 m (6.6 ft) from the path of a radar beam. A radar beam can normally be assumed to spread 20 degrees above and below the radiating element.
- The product is supplied from a separate battery from that used for engine start. This is important to prevent erratic behavior and data loss which can occur if the engine start does not have a separate battery.
- Raymarine specified cables are used.
- Cables are not cut or extended, unless doing so is detailed in the installation manual.

Note:

Where constraints on the installation prevent any of the above recommendations, always ensure the maximum possible separation between different items of electrical equipment, to provide the best conditions for EMC performance throughout the installation.

HV-100 product dimensions

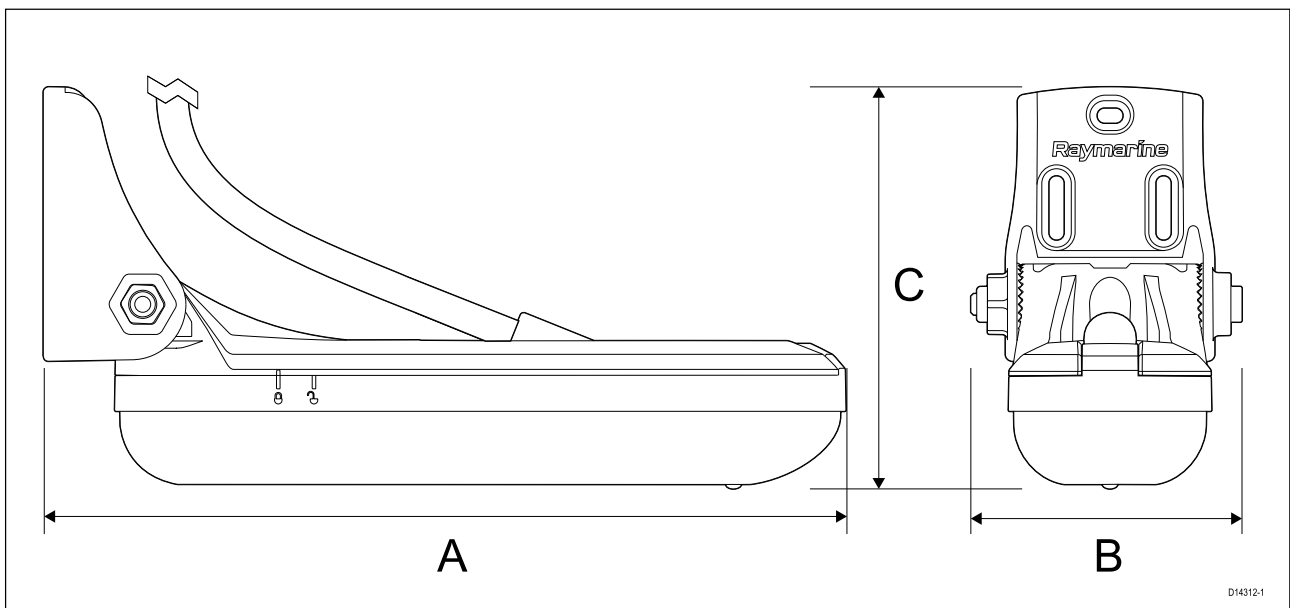

A	224.99 mm (8.86 in)
B	76.00 mm (2.99 in)
C	112.69 mm (4.44 in)

Transducer cable length: 6 m (19.69 ft).

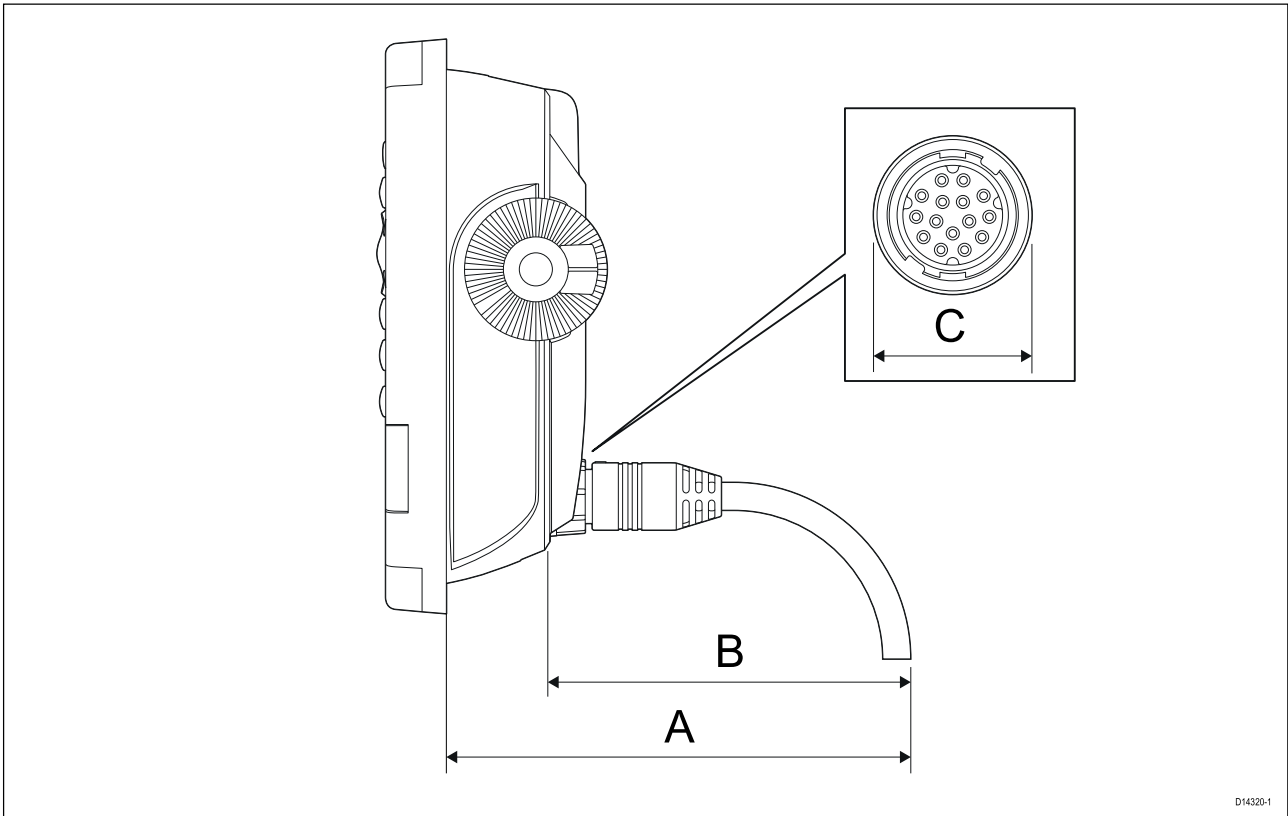

D14320-1

A	130.00 mm (5.12 in)
B	84.00 mm (3.31 in)
C	22.20 mm (0.87 in)

3.4 Mounting

Transducer assembly

Follow the steps below to assemble the transducer ready for attaching to the Transom bracket.

1. Slide the hanger bracket over the top of the transducer until the notch in the side of the bracket hanger aligns with the unlocked symbol on the side of the transducer.

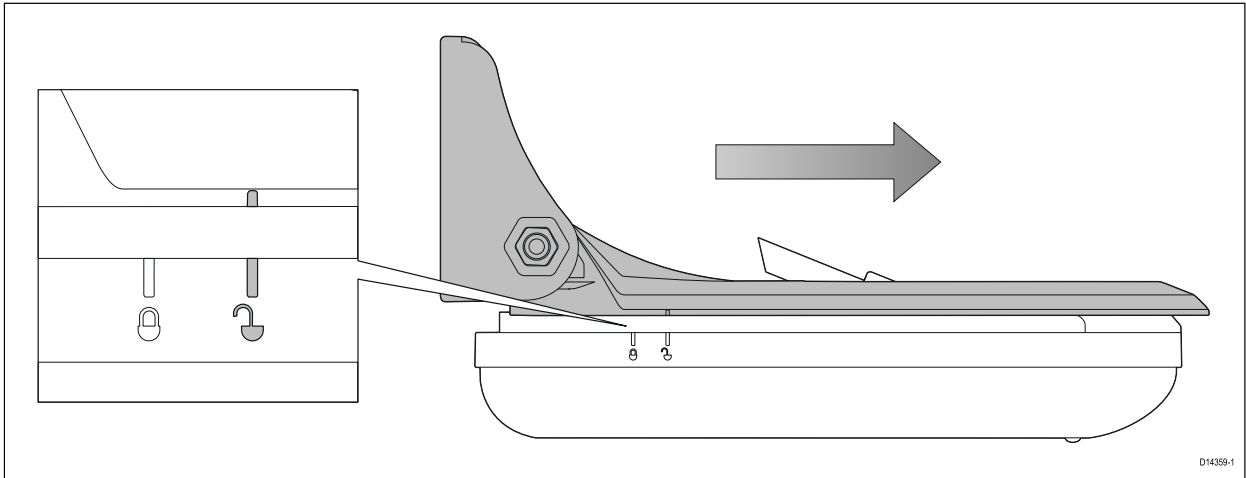

2. Allow the hanger bracket to move down into the slots on the top of the transducer.

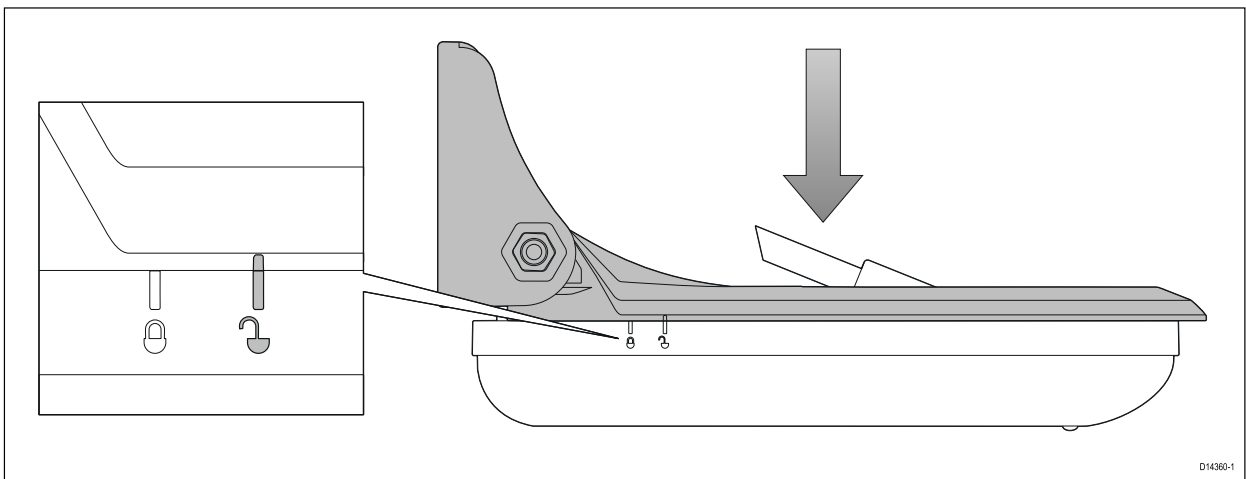

3. Slide the hanger bracket in the opposite direction from step 1, so that the notch in the side of the bracket hanger aligns with the locked symbol on the side of the transducer.

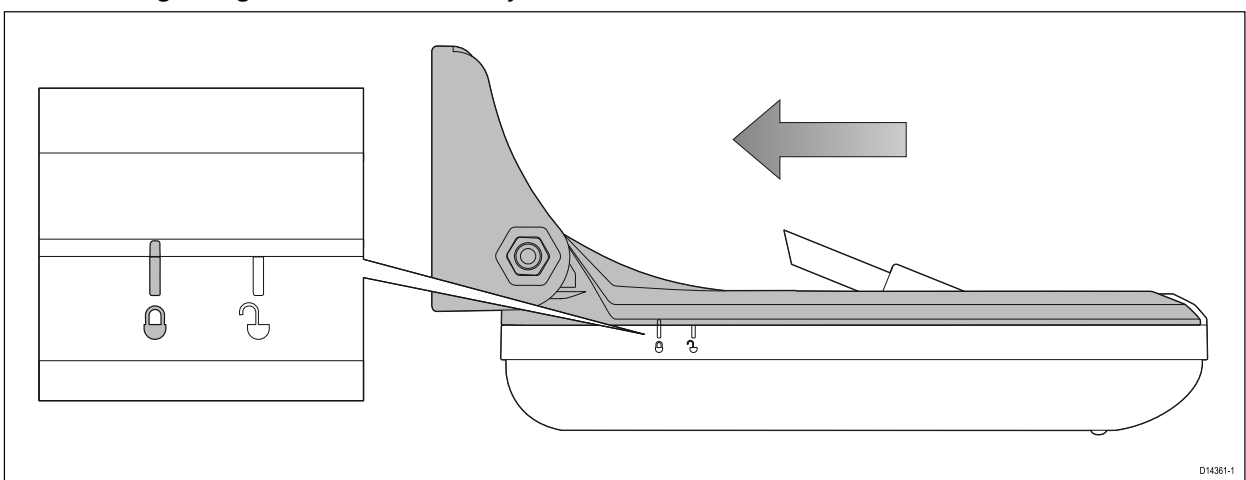

4. Secure the hanger bracket to the transducer, using a 4 mm Hex wrench (Allen key) and the supplied M5 hex bolt and washer.

Ensure tightening torque does not exceed 2 Nm (1.48 ft lb). Overtightening may cause damage to the transducer.

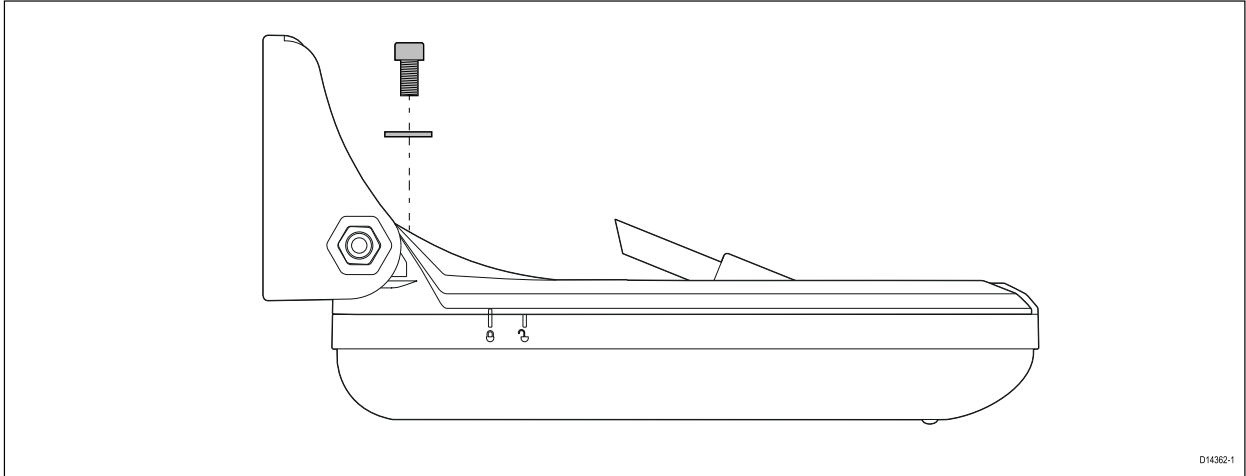

Mounting the transom bracket

The transducer must be mounted on the transom using the parts provided. The steps below describe the initial mounting steps required in order to test your transducer's performance. After testing the transducer you must finish the mounting using the instructions in the *Finishing the transducer mounting* section.

1. Fix the supplied transducer mounting template to the selected location, using masking or self-adhesive tape.

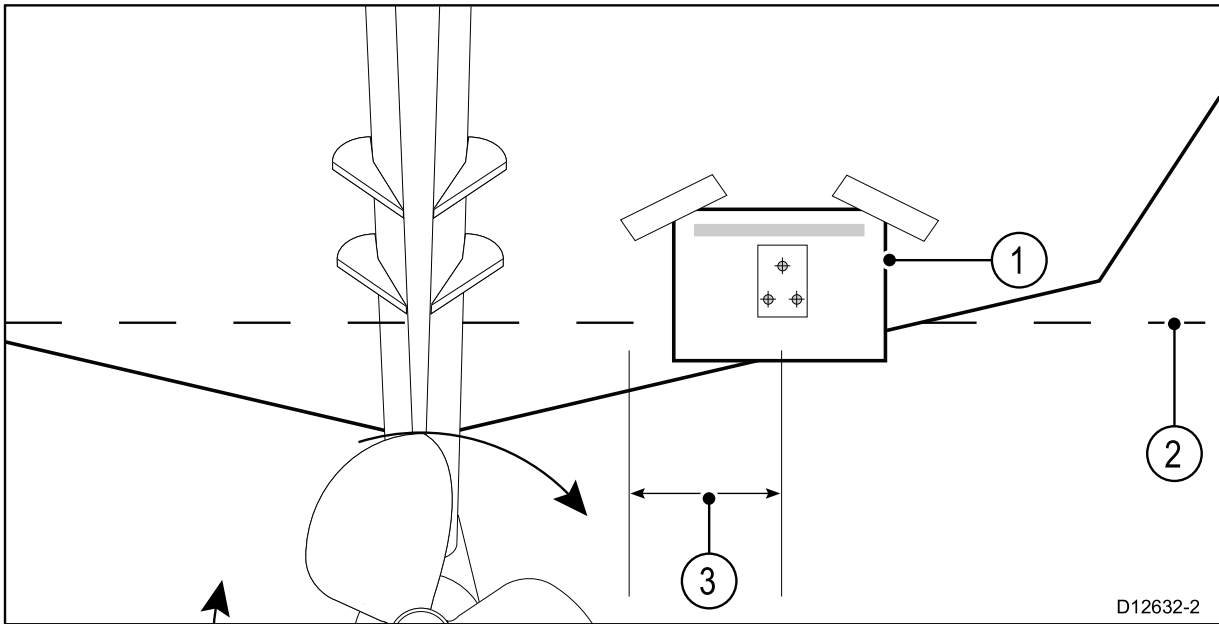

1	Transducer mounting template
2	Waterline
3	Mount away from the propeller

2. Ensure the template is parallel to the waterline.
3. Drill 2 x pilot holes for the adjustment slot screws as indicated on the template.

Note:

To help prevent chipping of the mounting surface, use painter's tape to mask the drill area.

Important:

Do NOT drill the third mounting hole at this stage.

4. Fill the 2 holes with marine grade sealant.
5. Insert the adjustment slot washers into the adjustment slots.

6. Using a pozi-drive screw driver and the screws provided, secure the transom bracket using the adjustment slots.

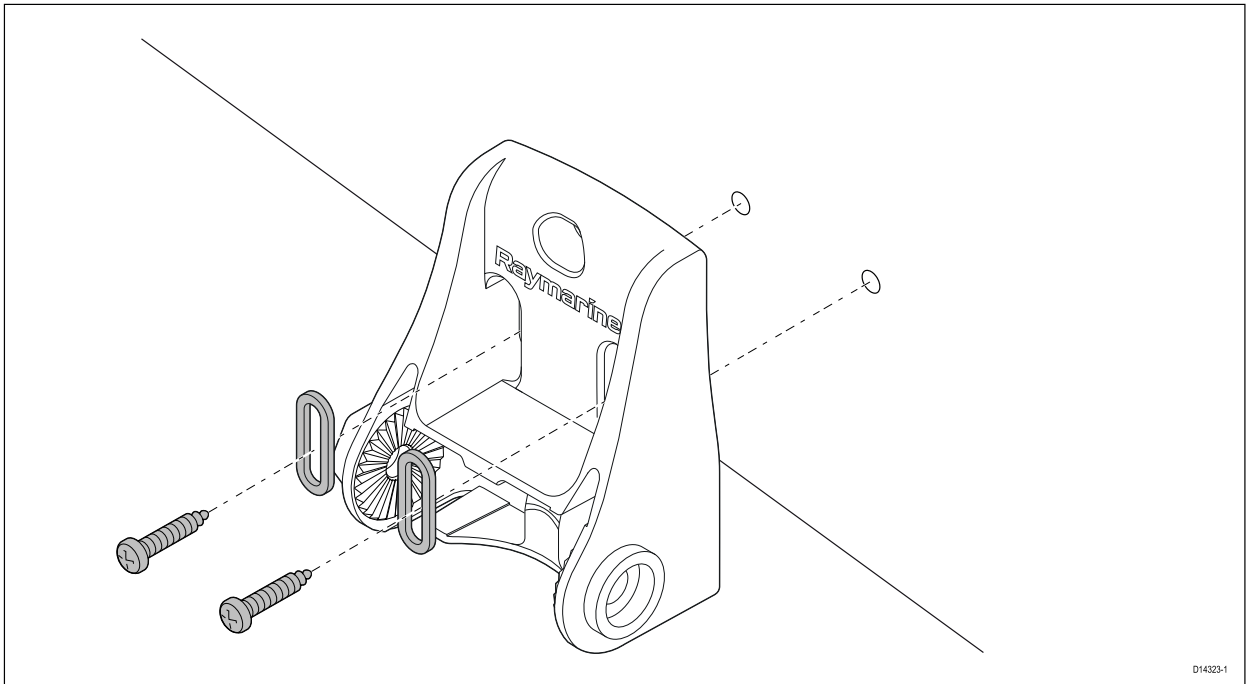

Note:

The third locking screw is not used until the transducer has been successfully tested.

Mounting the transducer assembly

Important:

- Only perform the installation with your vessel out of the water.
- Do NOT lift or suspend the transducer using its cable.
- Do NOT overtighten the bolt. Overtightening may cause damage to the transducer.

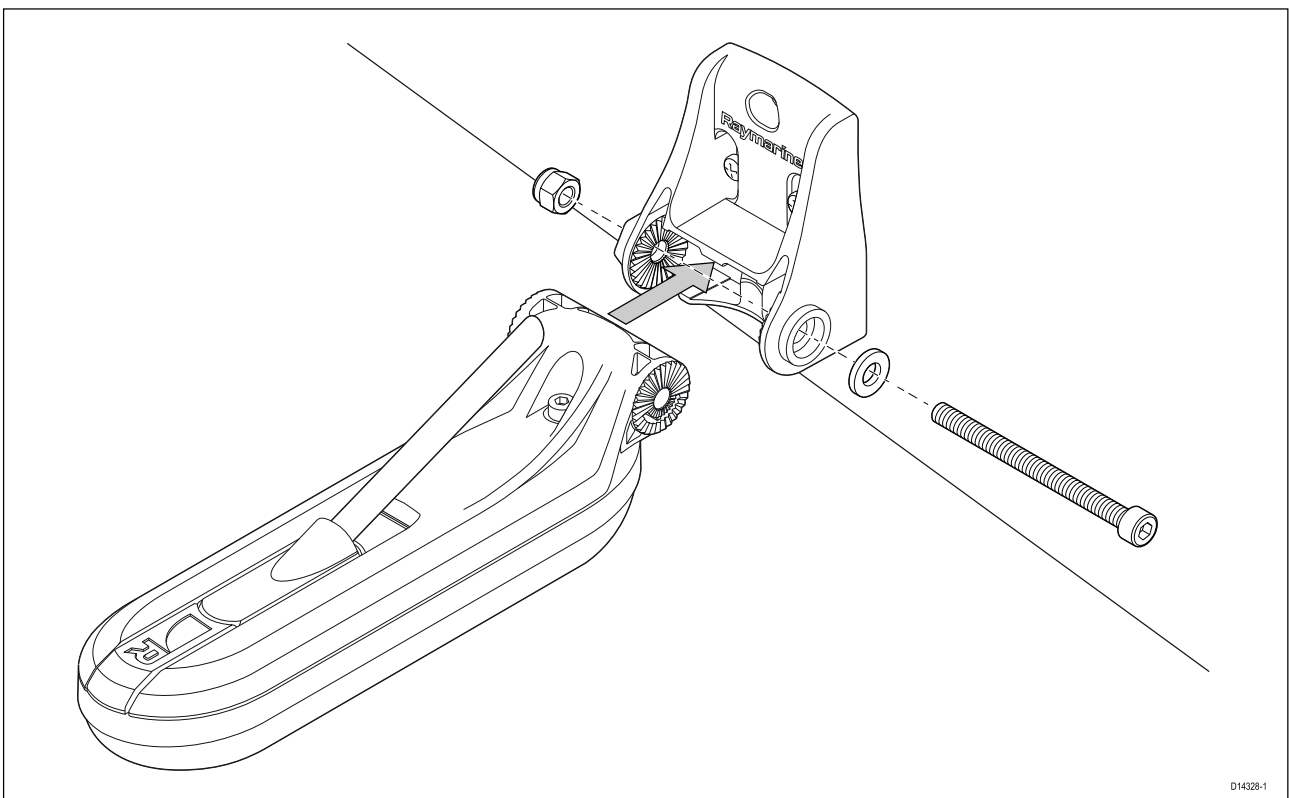

1. Position the transducer assembly in the transom bracket, ensuring that the ratchet grooves in the transom bracket are aligned with the ratchet grooves in the hanger bracket.

2. Slide the M6 metal washer over the M6 hex (Allen) bolt.
3. Slide the supplied M6 hex (Allen) bolt through the transom bracket hole.
4. Place the M6 locking nut into the captive area on the mounting bracket and hold in position.
5. Using a 5 mm Hex wrench ((Allen key), tighten the bolt onto the locking nut, until the transducer stays in position, but can still be adjusted (tilted) by hand.
6. Tilt the transducer so that the bottom face of the transducer will be parallel with the waterline and tighten the hex bolt until the hanger is held firmly in place.

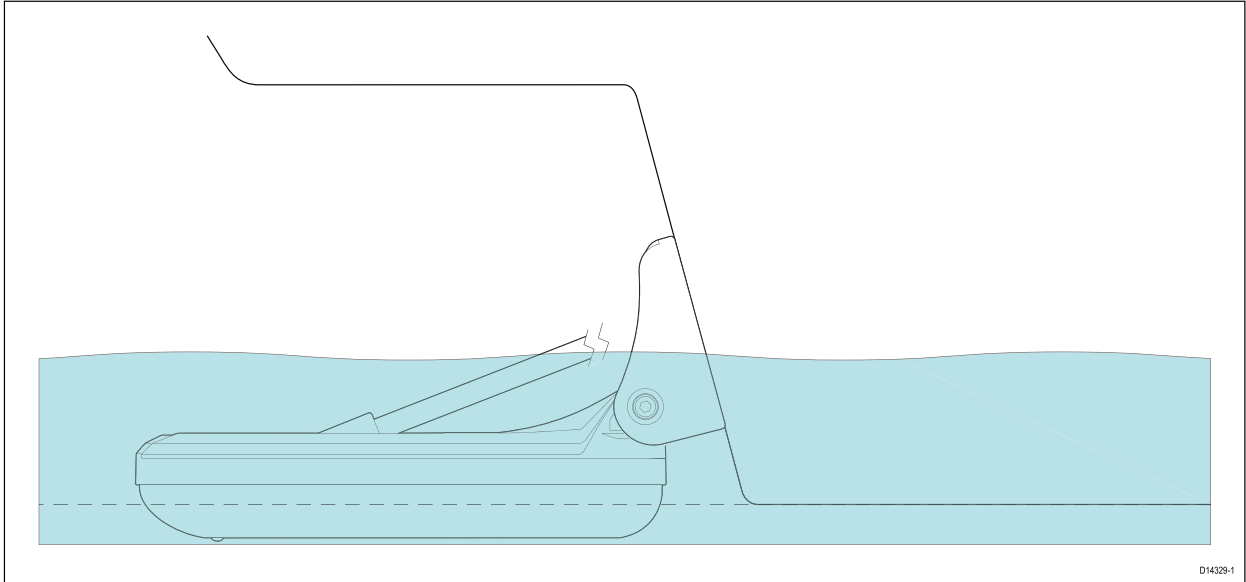

The transducer position will be adjusted further during testing.

Mounting the escutcheon plate

Your transducer is supplied with an escutcheon plate.

If you have chosen to route the transducer cable through the transom or through a bulkhead, you can use the supplied escutcheon plate to cover the hole required to accommodate the cable. The plate is designed to fit over a hole up to 25 mm (1 inch) in diameter.

After you have threaded the transducer cable through the hole in the transom or bulkhead, attach the escutcheon plate as shown, taking care that the cable is not trapped between the escutcheon plate and the mounting surface.

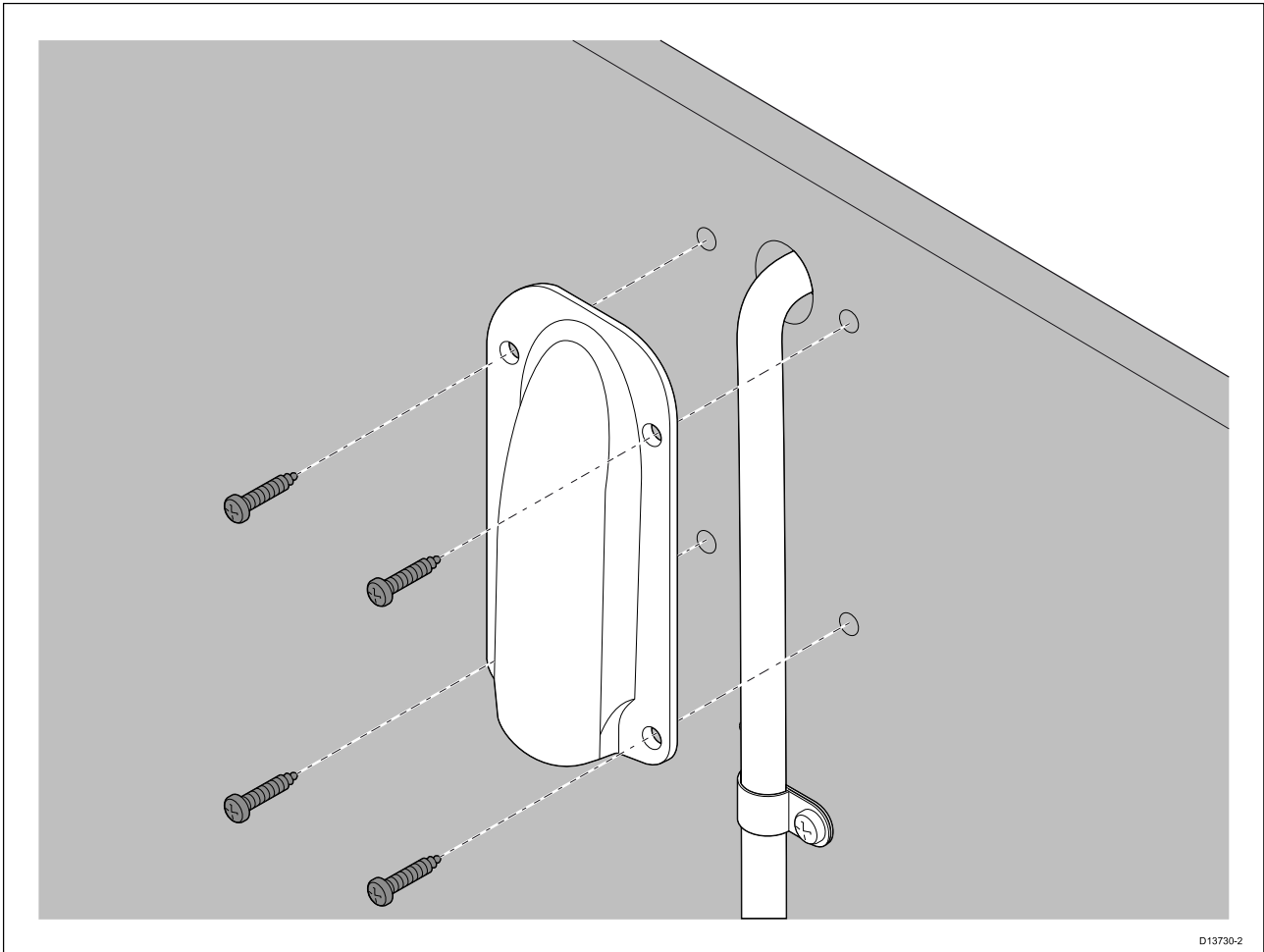

Note:

To avoid possible damage to the transducer cable, use a file to round-off the edges of the hole that the cable passes through.

Testing and adjusting the transducer

Once the initial mounting procedures have been carried out, the transducer must be tested before locking the transducer's position.

The testing should be carried out with your vessel in the water, with a depth greater than 0.7 m (2.3 ft) but less than the maximum depth range of the transducer.

1. Open the Fishfinder app on your display, and select the **Sonar** channel from the menu.
After a few seconds the bottom should be visible onscreen and a depth reading displayed.
2. Start moving your vessel at a low speed, ensuring you have a depth reading and a clear image is displayed.
3. Gradually increase the vessel speed whilst checking the display, if the image becomes poor or the bottom is missing at lower speeds then the transducer needs to be adjusted.
4. Angle and height adjustments should be made in small increments and re-tested each time until you obtain optimum performance.

For best performance, you should ensure that the bottom half of the transducer assembly is positioned so that it is lower than the lowest point of the hull closest to the transducer. In the following illustrations, the dashed line indicates the lowest point of the hull closest to the transducer.

- i. Loosen the mounting bolt to adjust the transducer angle.

Angle adjustment

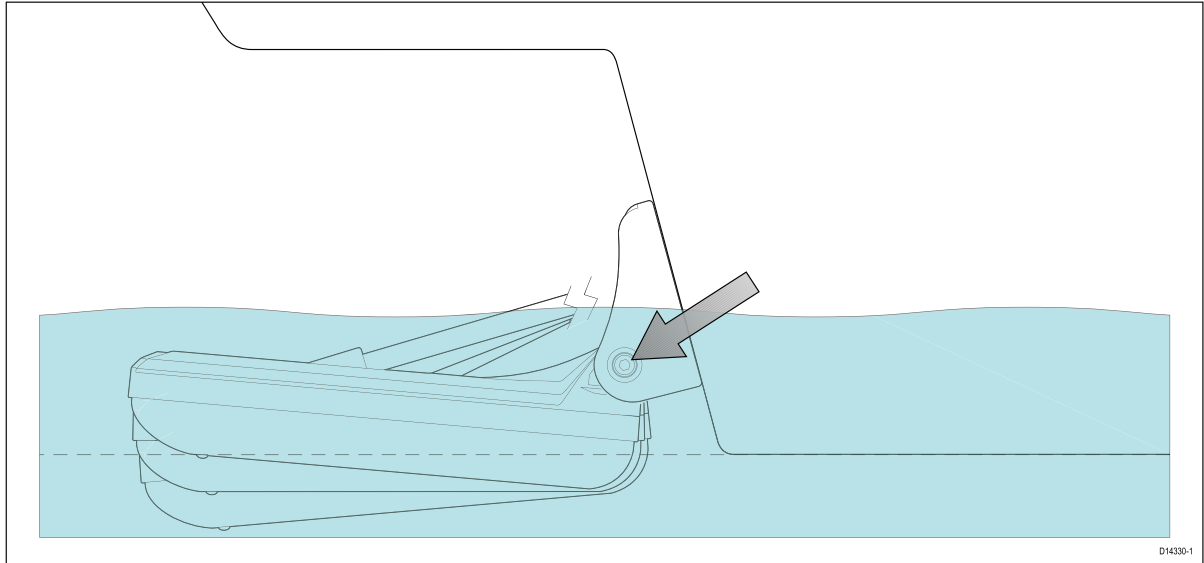

- ii. Loosen the 2 mounting bracket screws to adjust the transducer height.

Height adjustment

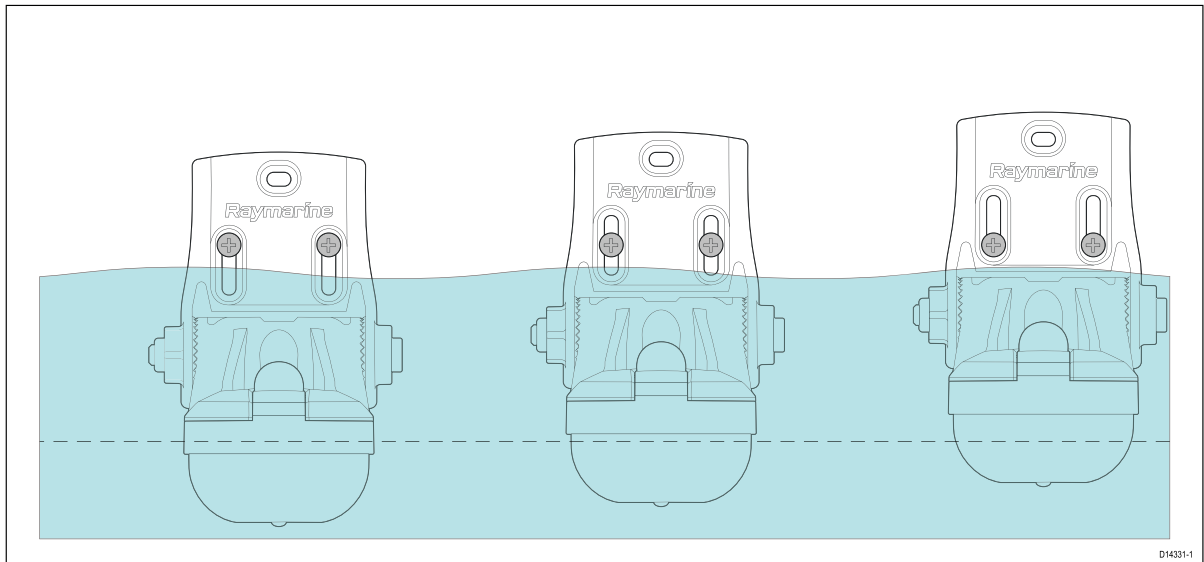

- iii. Re-tighten the mounting bolt and mounting screws before re-testing.

Note:

- It may be necessary to make several adjustments to the transducer before obtaining optimum performance.
- It may not always be possible to obtain depth readings at higher speeds due to air bubbles passing under the transducer.
- If the transducer requires repositioning ensure all old holes are filled with marine grade sealant.

Finalizing the transducer mounting

Once you have achieved optimum performance at the desired vessel speeds the transducer must be locked into position to complete the installation.

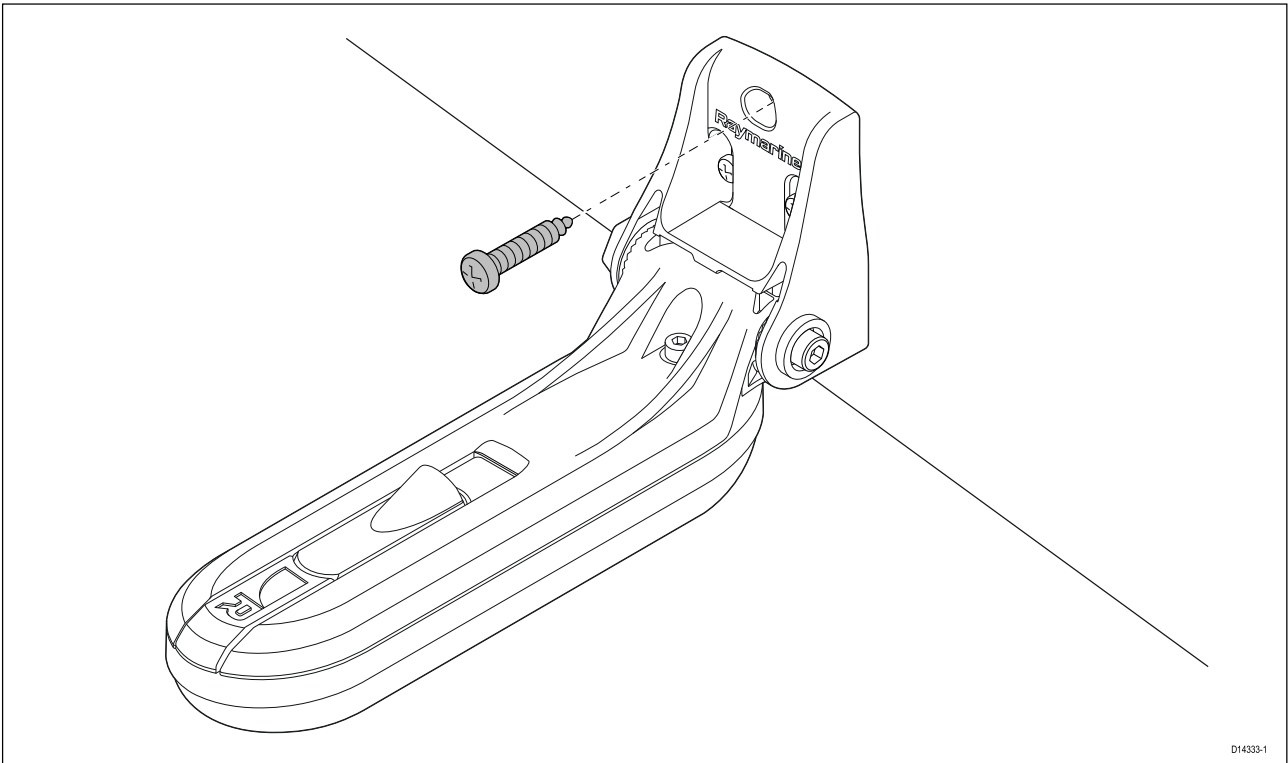

1. Drill the locking hole location taking care not to damage the transom bracket.
2. Fill the locking hole with marine grade sealant.
3. Lock the transducer position by fully tightening all 3 transom bracket mounting screws.
4. Lock the transducer angle by tightening the mounting bolt; do not exceed a torque of 4 Nm (2.95 ft lb). The transducer should not be easily moveable by hand, and should remain in its normal operating position when your vessel is underway.

Anti-fouling

Where local regulations allow, it is recommended that you coat your transducer using a water-based anti-fouling paint. This will help prevent the build-up of organic growth, which can reduce transducer performance.

Important:

- Before applying water-based anti-fouling paint, check that local environmental rules and regulations do not prohibit the use of anti-fouling paint.
- Never use copper-based anti-fouling paint as this can impact transducer performance.
- Never use keytone-based anti-fouling paint as this can attack the transducer's plastic, damaging the transducer.
- Paint your transducer using a brush, do not use a spray can or a sponge roller as these methods can cause tiny air bubbles to be incorporated in the paint, which will also reduce transducer performance.

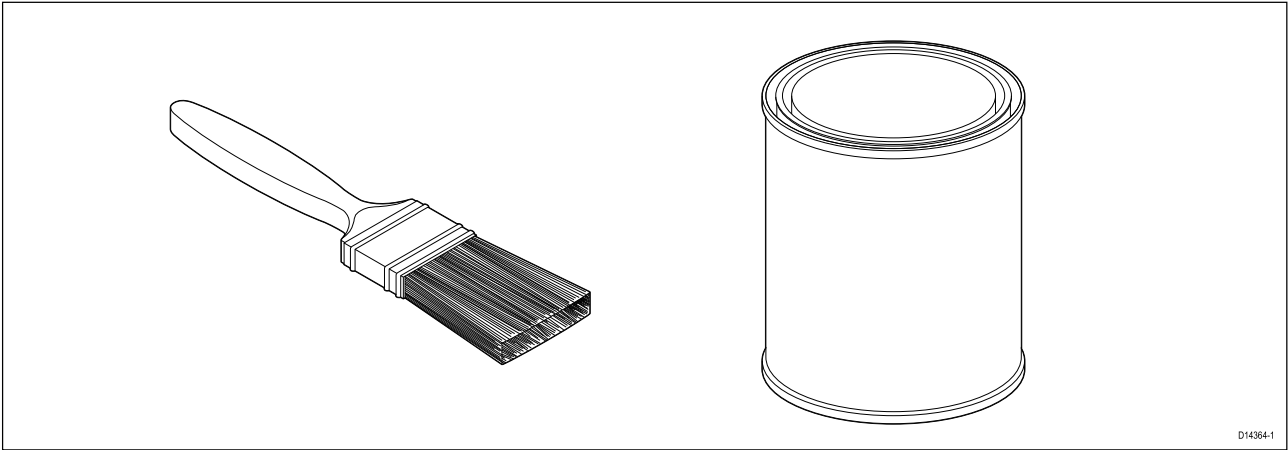

The anti-fouling paint should be applied in a thin and even coat covering all externally exposed transducer surfaces.

You should clean your transducer regularly and re-apply anti-fouling paint every 6 months, or sooner depending on how rapidly organic growth builds up.

Refer to [6.2 Transducer cleaning](#) for cleaning guidance.

For instructions on re-applying anti-fouling paint, refer to [6.3 Re-applying anti-fouling paint](#)

Chapter 4: Connections

Chapter contents

- [4.1 General cabling guidance on page 32](#)
- [4.2 Cable routing on page 33](#)
- [4.3 Making connections on page 34](#)

4.1 General cabling guidance

Cable types and length

It is important to use cables of the appropriate type and length

- Unless otherwise stated use only standard cables of the correct type, supplied by Raymarine.
- Ensure that any non-Raymarine cables are of the correct quality and gauge. For example, longer power cable runs may require larger wire gauges to minimize voltage drop along the run.

Strain relief

Ensure adequate strain relief is provided. Protect connectors from strain and ensure they will not pull out under extreme sea conditions.

Cable shielding

Ensure that all cables are properly shielded and that the cable shielding is undamaged.

Caution: Transducer cable

- Do NOT use the transducer cable to lift or suspend the transducer; always support the transducer body directly during installation.
- Do NOT cut, shorten, or splice the transducer cable.
- Do NOT remove the connector.

If the cable is cut, it cannot be repaired. Cutting the cable will also void the warranty.

4.2 Cable routing

Cable routing requirements for the transducer cable.

Important:

To avoid interference, the cable must be routed as far away from VHF radio antenna devices and cables as possible.

- Check that the cable is long enough to reach the display it will be connected to. Optional extension cables are available, if required.
- Ensure there is enough slack in the transducer cable, at the transducer end, to allow the transducer to pivot up and down during adjustment.
- If you intend to route the cable through the transom then you should use the supplied escutcheon plate to cover the hole..
- Secure the cable at regular intervals using the supplied cable clips.
- Any excess cable should be coiled up at a convenient location.

HyperVision™ transducer extension cable

For best performance, cable runs should be kept to a minimum. However, for some installations it may be necessary to extend the transducer cable.

A 4 m (13.12 ft) HyperVision™ transducer extension cable (A80562) is available

It is recommended that a maximum of one cable extensions is used, with the total cable length not exceeding 10 m (32.81 ft).

4.3 Making connections

Follow the steps below to connect the cable(s) to your product.

1. Ensure that the vessel's power supply is switched off.
2. Ensure that the device being connected to the unit has been installed in accordance with the installation instructions supplied with that device.
3. Ensuring correct orientation, push the cable connector fully onto the corresponding connector on the unit.
4. Turn the locking collar clockwise to secure the cable.

Chapter 5: System checks and troubleshooting

Chapter contents

- [5.1 Operation instructions on page 36](#)
- [5.2 Troubleshooting on page 37](#)

5.1 Operation instructions

For detailed operation instructions for your product, refer to the documentation that accompanies your display.

All product documentation is available to download from the Raymarine website:
www.raymarine.com/manuals.

5.2 Troubleshooting

The troubleshooting information provides possible causes and corrective action required for common problems associated with installation and operation of your product.

Before packing and shipping, all Raymarine products are subjected to comprehensive testing and quality assurance programs. If you do experience problems with your product this section will help you to diagnose and correct problems in order to restore normal operation.

If after referring to this section you are still having problems with your product, please refer to the Technical support section of this manual for useful links and Raymarine Product Support contact details.

Sonar troubleshooting

Scrolling image is not being displayed

Possible causes	Possible solutions
Sonar disabled	Enable Ping from the Sonar app's sounder tab: Menu > Settings > Sounder > Ping .
Incorrect transducer selected	Check that the correct transducer is selected in the Sonar app's Transducer tab: Menu > Settings > Transducer > Ping .
Damaged cables	<ol style="list-style-type: none"> 1. Check that the transducer cable connector is fully inserted and locked in position. 2. Check the power supply cable and connectors for signs of damage or corrosion, replace if necessary. 3. With the unit turned on, try flexing the cable near to the display connector to see if this causes the unit to re-boot/lose power, replace if necessary. 4. Check the vessel's battery voltage, the condition of the battery terminals and power supply cables, ensuring connections are secure, clean and free from corrosion, replace if necessary. 5. With the product under load, using a multi-meter, check for high voltage drop across all connectors/fuses etc (this can cause the Fishfinder applications to stop scrolling or the unit to reset/turn off), replace if necessary.
Damaged or fouled transducer	Check transducer condition, ensuring it is not damaged and is free from debris/fouling. If necessary, clean or replace your transducer. After cleaning or replacement coat the transducer using a water-based anti-fouling paint.
Wrong transducer fitted	Check product and transducer documentation and ensure that the transducer is compatible with your system.
External sonar module: SeaTalkhs / RayNet network problem.	<ul style="list-style-type: none"> • Check that the unit is correctly connected to the Display or network switch. Check all connections ensuring connections are secure, clean and free from corrosion, replace if necessary.
External sonar module: Software mismatch between equipment may prevent communication.	Ensure all Raymarine products contain the latest available software, check the Raymarine website: www.raymarine.com/software for software compatibility.

No depth reading / lost bottom lock

Possible causes	Possible solutions
Transducer location	Check that the transducer has been installed in accordance with the instructions provided with the transducer.
Transducer angle	If the transducer angle is too great the beam can miss the bottom, adjust transducer angle and recheck.
Transducer kicked-up	If the transducer has a kick-up mechanism, check that it has not kicked up due to hitting an object.

Possible causes	Possible solutions
Power source insufficient	With the product under load, using a multi-meter, check the power supply voltage as close to the unit as possible to establish actual voltage when the current is flowing. (Check your product's Technical specification for power supply requirements.)
Damaged or fouled transducer	Check transducer condition, ensuring it is not damaged and is free from debris/fouling. If necessary, clean or replace your transducer. After cleaning or replacement coat the transducer using a water-based anti-fouling paint.
Damaged cables	<ol style="list-style-type: none"> 1. Check the unit's connector for broken or bent pins. 2. Check that the cable connector is fully inserted into the unit and that the locking collar is in the locked position. 3. Check the cable and connectors for signs of damage or corrosion, replace if necessary. 4. With the unit turned on, try flexing the power cable near to the display connector to see if this causes the unit to re-boot/loose power, replace if necessary. 5. Check the vessel's battery voltage, the condition of the battery terminals and power supply cables, ensuring connections are secure, clean and free from corrosion, replace if necessary. 6. With the product under load, using a multi-meter, check for high voltage drop across all connectors/fuses etc (this can cause the Fishfinder applications to stop scrolling or the unit to reset/turn off), replace if necessary.
Vessel speed too high	Slow vessel speed and recheck.
Bottom too shallow or too deep	The bottom depth may be outside of the transducers depth range, move vessel to shallower or deeper waters as relevant and recheck.

Poor / problematic image

Possible causes	Possible solutions
Targets will appear differently if your vessel is stationary (e.g.: fish will appear on the display as straight lines).	Increase vessel speed.
Scrolling paused or speed set too low	Unpause or increase sonar scrolling speed.
Sensitivity settings may be inappropriate for present conditions.	Check and adjust sensitivity settings or perform a Sonar reset.
Damaged cables	<ol style="list-style-type: none"> 1. Check the unit's connector for broken or bent pins. 2. Check that the cable connector is fully inserted into the unit and that the locking collar is in the locked position. 3. Check the cable and connectors for signs of damage or corrosion, replace if necessary. 4. With the unit turned on, try flexing the power cable near to the display connector to see if this causes the unit to re-boot/loose power, replace if necessary. 5. Check the vessel's battery voltage, the condition of the battery terminals and power supply cables, ensuring connections are secure, clean and free from corrosion, replace if necessary. 6. With the product under load, using a multi-meter, check for high voltage drop across all connectors/fuses etc (this

Possible causes	Possible solutions
	can cause the Fishfinder applications to stop scrolling or the unit to reset/turn off), replace if necessary.
Transducer location	<ul style="list-style-type: none"> • Check that the transducer has been installed in accordance with the instructions provided with the transducer. • If a transom mount transducer is mounted too high on the transom it may be lifting out of the water, check that the transducer face is fully submerged when planing and turning.
Transducer kicked-up	If the transducer has a kick-up mechanism, check that it has not kicked up due to hitting an object.
Damaged or fouled transducer	Check transducer condition, ensuring it is not damaged and is free from debris/fouling. If necessary, clean or replace your transducer. After cleaning or replacement coat the transducer using a water-based anti-fouling paint.
Damaged transducer cable	Check that the transducer cable and connection is free from damage and that the connections are secure and free from corrosion.
Turbulence around the transducer at higher speeds may affect transducer performance	Slow vessel speed and recheck.
Interference from another transducer	<ol style="list-style-type: none"> 1. Turn off the transducer causing the interference. 2. Reposition the transducers so they are farther apart.
Unit power supply fault	Check the voltage from the power supply, if this is too low it can affect the transmitting power of the unit.

Resetting the sonar

You can reset the display's internal sonar module to its factory default settings following the steps below.

In the Fishfinder app:

1. Select **Menu**.
2. Select **Settings**.
3. Select **Sounder**.
4. Select **Reset sounder**.
5. Select **Yes** to confirm or **No** to abort the operation, as appropriate.

The internal sonar module will now be reset to factory default settings.

Chapter 6: Maintenance

Chapter contents

- 6.1 Routine checks on page 42
- 6.2 Transducer cleaning on page 43
- 6.3 Re-applying anti-fouling paint on page 44

6.1 Routine checks

The following periodic checks should be made:

- Examine cables for signs of damage, such as chafing, cuts or nicks.
- Check that the cable connectors are firmly attached and that their locking mechanisms are properly engaged.

Note: Cable checks should be carried out with the power supply switched off.



Warning: High voltage

This product contains high voltage. Adjustments require specialized service procedures and tools only available to qualified service technicians. There are no user serviceable parts or adjustments. The operator should never remove the cover or attempt to service the product.

6.2 Transducer cleaning

You must clean your transducer regularly to remove organic growth. Organic growth can build up quickly on the bottom face of your transducer; this can impact transducer performance in a matter of weeks.

Important:

- When cleaning growth from an anti-fouled transducer, take care not to let paint dust and other debris enter the water, as this can have an impact on aquatic life.
- Take care not to scratch the surface of the transducer as this can impact transducer performance.
- Do NOT use harsh cleaning solvents such as acetone as this will damage the transducer.

Follow the guidance below to clean growth from your transducer:

- use a soft cloth and a mild household cleaning detergent to clean mild growth build up.
- use a scouring pad, such as a green Scotch Brite™ pad and a mild household cleaning detergent to clean moderate growth build up.
- you may need to use a fine grade wet and dry paper and a mild household cleaning detergent to clean severe build up.

6.3 Re-applying anti-fouling paint

If you have applied anti-fouling paint to your transducer, it is important to re-apply it at least every 6 months, to maintain effectiveness.

Follow the instructions below to re-apply anti-fouling paint.

Important:

- Following environmental best practice, preparation and re-application of the anti-fouling paint should be performed using suitable washdown facilities, which ensures paint particles do not enter the water and impact aquatic life.
- Take care not to scratch the transducer face, as this may impact transducer performance.

1. Remove your vessel from the water.
2. Clean your transducer, ensuring all organic growth is removed.
3. Remove any flaking anti-foul paint.
4. Use a soft dry cloth to remove any loose bits of paint.
5. Re-apply a water-based anti-fouling paint.

Chapter 7: Technical support

Chapter contents

- 7.1 Raymarine product support and servicing on page 46
- 7.2 Learning resources on page 48

7.1 Raymarine product support and servicing

Raymarine provides a comprehensive product support service, as well as warranty, service, and repairs. You can access these services through the Raymarine website, telephone, and e-mail.

Product information

If you need to request service or support, please have the following information to hand:

- Product name.
- Product identity.
- Serial number.
- Software application version.
- System diagrams.

You can obtain this product information using diagnostic pages of the connected MFD.

Servicing and warranty

Raymarine offers dedicated service departments for warranty, service, and repairs.

Don't forget to visit the Raymarine website to register your product for extended warranty benefits:

<http://www.raymarine.co.uk/display?id=788>.

Region	Contact
United Kingdom (UK), EMEA, and Asia Pacific	<ul style="list-style-type: none">• E-Mail: emea.service@raymarine.com• Tel: +44 (0)1329 246 932
United States (US)	<ul style="list-style-type: none">• E-Mail: rm-usrepair@flir.com• Tel: +1 (603) 324 7900

Web support

Please visit the "Support" area of the Raymarine website for:

- **Manuals and Documents** — <http://www.raymarine.com/manuals>
- **FAQ / Knowledgebase** — <http://www.raymarine.com/knowledgebase>
- **Technical support forum** — <http://forum.raymarine.com>
- **Software updates** — <http://www.raymarine.com/software>

Worldwide support



Region	Contact
United Kingdom (UK), EMEA, and Asia Pacific	<ul style="list-style-type: none">• E-Mail: support.uk@raymarine.com• Tel: +44 (0)1329 246 777
United States (US)	<ul style="list-style-type: none">• E-Mail: support@raymarine.com• Tel: +1 (603) 324 7900 (Toll-free: +800 539 5539)
Australia and New Zealand (Raymarine subsidiary)	<ul style="list-style-type: none">• E-Mail: aus.support@raymarine.com• Tel: +61 2 8977 0300
France (Raymarine subsidiary)	<ul style="list-style-type: none">• E-Mail: support.fr@raymarine.com• Tel: +33 (0)1 46 49 72 30
Germany (Raymarine subsidiary)	<ul style="list-style-type: none">• E-Mail: support.de@raymarine.com• Tel: +49 (0)40 237 808 0
Italy (Raymarine subsidiary)	<ul style="list-style-type: none">• E-Mail: support.it@raymarine.com• Tel: +39 02 9945 1001
Spain (Authorized Raymarine distributor)	<ul style="list-style-type: none">• E-Mail: sat@azimut.es• Tel: +34 96 2965 102
Netherlands (Raymarine subsidiary)	<ul style="list-style-type: none">• E-Mail: support.nl@raymarine.com• Tel: +31 (0)26 3614 905

Region	Contact
Sweden (Raymarine subsidiary)	<ul style="list-style-type: none"> • E-Mail: support.se@raymarine.com • Tel: +46 (0)317 633 670
Finland (Raymarine subsidiary)	<ul style="list-style-type: none"> • E-Mail: support.fi@raymarine.com • Tel: +358 (0)207 619 937
Norway (Raymarine subsidiary)	<ul style="list-style-type: none"> • E-Mail: support.no@raymarine.com • Tel: +47 692 64 600
Denmark (Raymarine subsidiary)	<ul style="list-style-type: none"> • E-Mail: support.dk@raymarine.com • Tel: +45 437 164 64
Russia (Authorized Raymarine distributor)	<ul style="list-style-type: none"> • E-Mail: info@mikstmarine.ru • Tel: +7 495 788 0508

7.2 Learning resources

Raymarine has produced a range of learning resources to help you get the most out of your products.

Video tutorials

 YouTube	Raymarine official channel on YouTube: <ul style="list-style-type: none">• http://www.youtube.com/user/RaymarineInc LightHouse™ 3 tips and tricks: <ul style="list-style-type: none">• http://www.raymarine.com/multifunction-displays/light-house3/tips-and-tricks
	Video Gallery: <ul style="list-style-type: none">• http://www.raymarine.co.uk/view/?id=2679

Note:

- Viewing the videos requires a device with an Internet connection.
- Some videos are only available in English.

Training courses

Raymarine regularly runs a range of in-depth training courses to help you make the most of your products. Visit the Training section of the Raymarine website for more information:

- <http://www.raymarine.co.uk/view/?id=2372>

FAQs and Knowledge Base

Raymarine has produced an extensive set of FAQs and a Knowledge Base to help you find more information and troubleshoot any issues.

- <http://www.raymarine.co.uk/knowledgebase/>

Technical support forum

You can use the Technical support forum to ask a technical question about a Raymarine product or to find out how other customers are using their Raymarine equipment. The resource is regularly updated with contributions from Raymarine customers and staff:

- <http://forum.raymarine.com>

Chapter 8: Technical specification

Chapter contents

- [8.1 Technical specification on page 50](#)

8.1 Technical specification

Physical specification

Overall dimensions:	<ul style="list-style-type: none"> • Length: 224.99 mm (8.86 in) • Height: 112.69 mm (4.44 in) • Width: 76.00 mm (2.99 in)
Cable length:	• HV-100: 6 m (19.69 ft) fitted cable
Weight (unboxed):	1.05 kg (2.31 lb)

Environmental specification

Operating temperature	−2°C (28.4°F) to + 55°C (131°F)
Storage temperature	−20°C (23°F) to + 70°C (158°F)
Waterproof rating	<ul style="list-style-type: none"> • IPx6 (surfaces exterior to hull, only) • IPx7 • IPx8

HyperVision™ technical specification

The following specification only applies to HyperVision™ products.

Frequencies	<ul style="list-style-type: none"> • 1.2 MHz CHIRP • 350 kHz CHIRP • 200 kHz CHIRP
Channels	<ul style="list-style-type: none"> • Conical CHIRP sonar • RealVision™ 3D (Hyper) • RealVision™ 3D (Standard) • SideVision™ (Hyper) • SideVision™ (Standard) • DownVision™ (Hyper) • DownVision™ (Standard)
200 kHz range	• Conical CHIRP sonar = 0.6 M (2 ft) to 274 m (900 ft)
350 kHz range	<ul style="list-style-type: none"> • RealVision™ 3D = 0.6 M (2 ft) to 91 m (300 ft) • SideVision™ = 0.6 M (2 ft) to 91 m (300 ft) each side • DownVision™ = 0.6 M (2 ft) to 183 m (600 ft)
1.2 MHz range	<ul style="list-style-type: none"> • RealVision™ 3D = 0.6 M (2 ft) to 38 m (125 ft) • SideVision™ = 0.6 M (2 ft) to 38 m (125 ft) each side • DownVision™ = 0.6 M (2 ft) to 38 m (125 ft)

Conformance specification

Conformance	<ul style="list-style-type: none"> • EN 60945:2002 • IEC 28846:1993 • EMC Directive 2014/30/EU • Australia and New Zealand: C-Tick, Compliance Level 2
--------------------	--

Chapter 9: Spares and accessories

Chapter contents

- [9.1 Spares on page 52](#)
- [9.2 Accessories on page 53](#)

9.1 Spares

Description	Part number
HV-100 Transom bracket	R70651

9.2 Accessories

Description	Part number
HV-100 trolling motor mount	A80557
HyperVision™ transducer extension cable 4 m (13.12 ft)	A80562

Index

A

Accessories	52–53
Anti-fouling	17, 28, 44
Assembly	22

C

Cable extension	33
Cable protection	32
Cable routing	33
Cleaning the transducer	43
Connections	
General cabling guidance	32
Contact details	46

D

Documentation	
Installation instructions	10
Mounting template	10
Operation instructions	10, 36

E

Electromagnetic Compatibility	20
EMC, <i>See</i> Electromagnetic Compatibility	
Escutcheon plate	25

F

FAQs	48
------------	----

H

HV-100	
Compatible displays	13
HV-100 transducer	11

I

Installation	
Testing	18, 26

K

Knowledge base	48
----------------------	----

L

LightHouse™ 3	
Tips and Tricks	48
LightHouse Sport	
Compatible displays	13
Location requirements	
General	19

M

Maintenance	7
-------------------	---

O

Operation instructions	10, 36
------------------------------	--------

P

Product recycling (WEEE)	8
Product support	46

S

Service Center	46
Servicing	7
Strain relief, <i>See</i> Cable protection	
Support forum	48

T

Technical specification	49–50
Technical Specification	
Conformance	50
Environmental	50
HyperVision Sonar	50
Physical	50
Technical support	46, 48
Training courses	48
Transducer mounting	24
Troubleshooting	37

V

Video Gallery	48
---------------------	----

W

Warranty	46
WEEE Directive	8



Raymarine

Marine House, Cartwright Drive, Fareham, Hampshire.
PO15 5RJ. United Kingdom.

Tel: +44 (0)1329 246 700

www.raymarine.com

Raymarine®

a brand by  **FLIR®**