

## Product Specifications SE 80/185 T



The **SE80/185T** suits a wide range of boats around the 12m/40' mark and is thereby a very popular model. Utilizing the same mechanical parts as the even more powerful SE100/185T, the reduced power makes it an exceptionally energy efficient thruster demanding less from the electric installation as well as being a very cost efficient model with a compact installation size. The **SE80/185T** includes all the important and unique **Side-Power** features and qualities - **why settle for less.**

### Easy and safe to install:

- Easy access terminals for easy, fast and safe fitting of main battery cables (as opposed to having to fit directly onto "crowded" solenoid studs. Own by overheat sensor in motor.
- Plug and go control wiring.
- Fast, easy and safe fitting of propeller with lock-nut as opposed to difficult and unreliable set-screw fastening.
- Self aligning drilling template available for OEM customers.

### Description:

Typical boat size	35 - 48 foot (see back for more info)
Tunnel inside diameter	185mm/7,3" (see back for more measurements)
Propulsion system	Twin
Available for DCsystem	12V or 24V
Weight	20kg/44lbs.

### Gearleg:

- Seawater resistant bronze, CNC machined in one process to ensure 100% correct tolerances, angles and measurements.
- Sealed gearleg with long-life "mechanical" seal where polished ceramic and carbon surfaces form the only moving sealing surfaces, ensuring protection against damaging water intrusion into gear leg.
- Lifetime lubricated with special gear-oil.
- Hardened and ground precision spiro-conical gears.
- Propeller shaft with double ball bearings fitted in correct tolerances.
- Driveshaft with ball bearing and special sleeve bearing in correct tolerances.
- Connection between motor and driveshaft by flexible coupler
- 5 bladed composite "Q-prop" propeller, skewback design.
- Zinc anode protection directly on gearleg, easy to access and change.
- Gearleg galvanically insulated from bracket/motor

### Performance and specifications at one tunnel diameter depth\* :

	At 10,5V/21V	At 12,0V/24V
Thrust	80kg/176lbs.	< 96kg/212lbs.
Output power	4,4kW/6 Hp	< 5,6kW/7,6Hp
Average current draw	530A/260A	< 600A/320A
Continuous run time (20°C)	3 min.	> 2,5 min.
Approx. long term run time	10% of time	6% of time
Min. battery CCA rating 12V/24V	550/300 CCA DIN - 1045/570 CCA SAE	
Sidepower fuse size:	ANL400/ANL250	

### Safety features on thruster (see separate sheet for control panels):

- Forced shut-down by overheat sensor in motor
- All internal leads with extra insulation of webbed silicon increase resistance to heat and mechanical wear. Connectors have positive locking so that you have to pull by the insulator to release, can not be pulled off by the wires or loosen by themselves. Self extinguishing solenoid cover.
- IPC Standard electronic control box for protection against:
  - direct drive direction change
  - unique, patented protection of solenoid from extra wear and damages in low voltage situations for example caused by drained or damaged batteries as well as "auto-stop" without the need for the skipper to shut down the main switch immediately to stop the thruster in case of a solenoid lock-in\*\*
  - auto-stop if control signal is continuous for more than 3 minutes to protect against potential short circuit in control cables.

### Notes !

\* Actual performances, current consumption etc. will vary for each installation depending on many factors. Specifications here given at one tunnel diameter depth and with voltage at thruster as shown. If you install deeper the thrust will be more as well as the current consumption, and the running time will be reduced. Electromotors power and efficiency tolerances are +/- 6%.

\*\* Patented safety features in the thruster controlbox.

# Product Specifications SE 80/185 T

## Installation planning

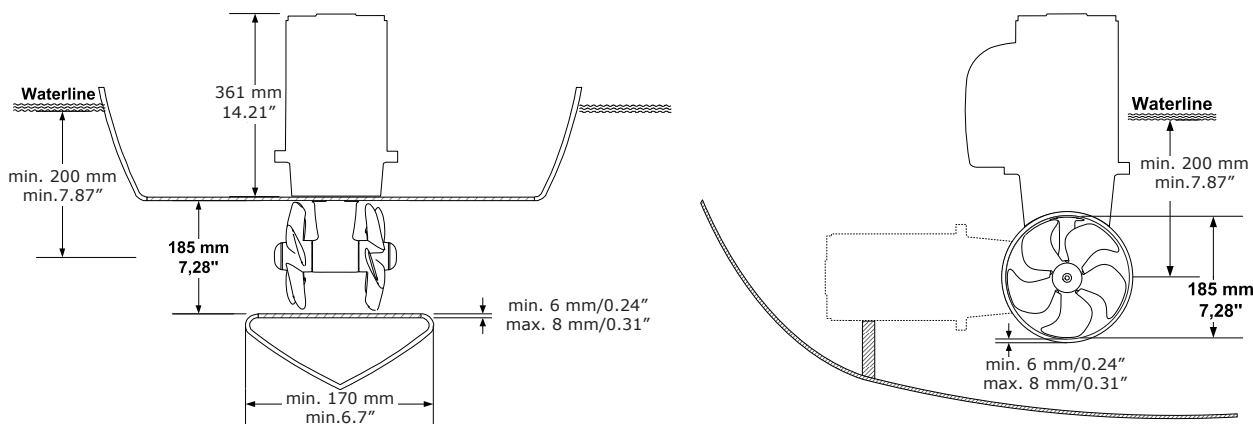

Battery & cable recommendations:

Model	Voltage	Nominal current draw	Min. battery CCA		>7m total + & -		7-14m total + & -		15-21m total + & -		22-28m total + & -		28-35m total + & -		36-45m total + & -	
					Min.	Rec.	Min.	Rec.	Min.	Rec.	Min.	Rec.	Min.	Rec.	Min.	Rec.
SE80/185T	12 V	530 A	DIN: 550 SAE:1045	mm <sup>2</sup> AWG	60 2/0	70 2/0	95 3/0	2x 70 2x 2/0	2x 70 2x 2/0	2x 95 2x 2/0	2x 95 2x 3/0	270*	2x 120 2x 4/0	340*	NA	NA
	24 V	260 A	DIN: 300 SAE: 570	mm <sup>2</sup> AWG	25 1	35 1	35 1	50 1/0	60 2/0	70 2/0	70 2/0	95 3/0	95 3/0	120 4/0	120 4/0	2x 95 2x 3/0

Minimum and recommended cable dimensions can be identical due to safety margins and cable heat considerations for short cable lengths.

\* Minimum or recommended cable cross section in mm<sup>2</sup>

Riva Rivarama 44 - 21,9 knots



Fairline Targa 38 - 23,5 knots



Meridian 368 MY - 21,1 knots

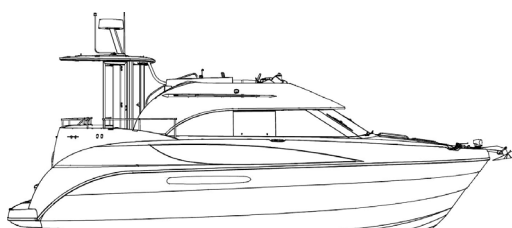

Bavaria 42 Cruiser - 21,4 knots

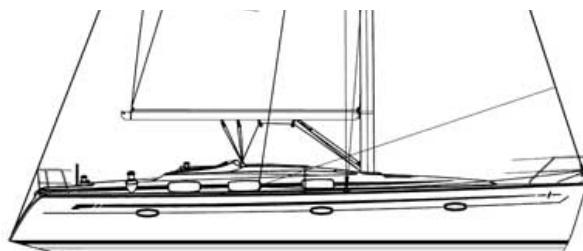

**Typical boat sizes:**  
SE80/185T push the bow against a direct sidewind of approximately:



This document may contain typographical errors, to which Sleipner Motor assumes no responsibility.

